

Регулятор температуры RES-5012

Инструкция по эксплуатации

По вопросам продаж и поддержки обращайтесь:

Алматы (727)345-47-04
Ангарск (3955)60-70-56
Архангельск (8182)63-90-72
Астрахань (8512)99-46-04
Барнаул (3852)73-04-60
Белгород (4722)40-23-64
Благовещенск (4162)22-76-07
Брянск (4832)59-03-52
Владивосток (423)249-28-31
Владикавказ (8672)28-90-48
Владимир (4922)49-43-18
Волгоград (844)278-03-48
Вологда (8172)26-41-59
Воронеж (473)204-51-73
Екатеринбург (343)384-55-89

Иваново (4932)77-34-06
Ижевск (3412)26-03-58
Иркутск (395)279-98-46
Казань (843)206-01-48
Калининград (4012)72-03-81
Калуга (4842)92-23-67
Кемерово (3842)65-04-62
Киров (8332)68-02-04
Коломна (4966)23-41-49
Кострома (4942)77-07-48
Краснодар (861)203-40-90
Красноярск (391)204-63-61
Курск (4712)77-13-04
Курган (3522)50-90-47
Липецк (4742)52-20-81

Магнитогорск (3519)55-03-13
Москва (495)268-04-70
Мурманск (8152)59-64-93
Набережные Челны (8552)20-53-41
Нижний Новгород (831)429-08-12
Новокузнецк (3843)20-46-81
Ноябрьск (3496)41-32-12
Новосибирск (383)227-86-73
Омск (3812)21-46-40
Орел (4862)44-53-42
Оренбург (3532)37-68-04
Пенза (8412)22-31-16
Петрозаводск (8142)55-98-37
Псков (8112)59-10-37
Пермь (342)205-81-47

Ростов-на-Дону (863)308-18-15
Рязань (4912)46-61-64
Самара (846)206-03-16
Санкт-Петербург (812)309-46-40
Саратов (845)249-38-78
Севастополь (8692)22-31-93
Саранск (8342)22-96-24
Симферополь (3652)67-13-56
Смоленск (4812)29-41-54
Сочи (862)225-72-31
Ставрополь (8652)20-65-13
Сургут (3462)77-98-35
Сыктывкар (8212)25-95-17
Тамбов (4752)50-40-97
Тверь (4822)63-31-35

Тольятти (8482)63-91-07
Томск (3822)98-41-53
Тула (4872)33-79-87
Тюмень (3452)66-21-18
Ульяновск (8422)24-23-59
Улан-Удэ (3012)59-97-51
Уфа (347)229-48-12
Хабаровск (4212)92-98-04
Чебоксары (8352)28-53-07
Челябинск (351)202-03-61
Череповец (8202)49-02-64
Чита (3022)38-34-83
Якутск (4112)23-90-97
Ярославль (4852)69-52-93

Россия +7(495)268-04-70

Казахстан +(727)345-47-04

Беларусь +(375)257-127-884

Узбекистан +998(71)205-18-59

Киргизия +996(312)96-26-47

эл.почта: rx@nt-rt.ru || сайт: <https://ropex.nt-rt.ru/>

Revision History

Version	Change	Refer to section
2	New edition of documentation	
3	Communications protocol expanded: command bit constant regulation ratio	Constant regulation ratio (KS) [▶ 43]
	New section	Restart delay after reset [▶ 56]
	New section	Maximum measurement pause [▶ 56]
	Expansion of object index: Restart delay after reset (object 0x4014) and maximum measurement pause (object 0x4015)	Object index [▶ 44]
4	Expansion of object index: TCR calculator (object 0x430A)	Object index [▶ 44]
	New section	TCR calculator [▶ 51]
	New: Voltage supply range changed to max. 480 VAC	Technical data [▶ 78]
5	Addition: LED AC flashes slowly, waiting for line voltage	Display and operating elements [▶ 36]
	Addition: List "Blocking AUTOCAL function"	Automatic zero calibration AUTOCAL (AC) [▶ 39]
	Addition: Regulation ratio of 0% to 3%	Constant regulation ratio (KS) [▶ 43]
	Addition: Note	Alarm active (AL)
	Addition: Standby function active (bit SA)	Standby active (SA)
	Distinction: Voltage alarm relay for UL approval, 24 VDC supply inrush current and control mode	Technical data [▶ 78]
6	New section and addition: Meaning of warning symbols on housing	Symbols on the device [▶ 12]
	Additions	Essential system components [▶ 17]
	Table revised	Temperature range and alloy [▶ 50]
7	Documentation revised	All
	Section "Commissioning" revised	Startup [▶ 28]
	Current transformer PEX-W4 removed	Current transformer [▶ 19]
	New error codes beginning FW version 313	Error messages [▶ 69]
	Declaration of conformity amended	Declaration of Conformity [▶ 82]
	Section "Annex" expanded to include an example of electrical cabinet wiring and examples of electrical connections	Appendix [▶ 84]

Table of Contents

	Revision History	3
1	Information on these operating instructions	7
1.1	Purpose of operating instructions	7
1.2	Target group	7
1.3	Validity of the operating instructions	7
1.4	Related documents	7
1.4.1	Related software applications	7
1.5	Storing documentation	7
1.6	Quality	7
1.7	Typography	8
2	Intended use	9
2.1	Ambient conditions	9
3	Safety	10
3.1	Safety regulations	10
3.2	How warnings are structured	10
3.3	Symbols on the device	12
3.4	Conformity	12
3.5	Rules	12
3.6	Obligation of user	12
4	Description of project	14
4.1	Functioning	14
4.2	Application	14
4.3	Properties	14
4.4	Overview	15
4.4.1	ID plate	16
4.4.2	Dimensions	16
4.5	Essential system components	17
4.5.1	Control loop components	17
4.5.2	Heat-sealing band	18
4.5.3	Pulse transformer	19
4.5.4	Current transformer	19
4.5.5	Line filters	20
4.5.6	Measurement cable	20
4.6	Optional system components	20
4.6.1	Booster	20
5	Assembly and installation	21
5.1	Transporting and checking device	21
5.2	Scope of delivery	21
5.3	Installation site requirements	21
5.4	Device assembly	22
5.5	Installation of device	22
5.5.1	Power supply	24

5.5.2	Connection diagram	26
6	Startup	28
6.1	Initial startup	28
6.2	Restarting device	30
6.3	LED behavior upon startup	31
6.4	Temperature controller configuration	32
6.4.1	Current transformer configuration	32
6.4.2	Setting coding dial for temperature range and alloy	33
6.4.3	Setting coding dials for device ID	33
6.4.4	Alarm relay configuration	34
6.5	Burning in heat-sealing band	34
7	Display and operating elements	36
8	Functions and settings	38
8.1	Communication via interface	38
8.2	Device master file (ESI)	38
8.3	Communication protocol	39
8.4	Input data	39
8.4.1	Automatic zero calibration AUTOCAL (AC)	39
8.4.2	Start (ST)	41
8.4.3	Reset (RS)	41
8.4.4	Measurement pause (MP)	42
8.4.5	Master AUTOCAL (MA)	42
8.4.6	Constant regulation ratio (KS)	43
8.4.7	Channel selection (CH0...CH2)	43
8.4.8	Setpoint	44
8.5	Object index	44
8.5.1	Temperature range and alloy	50
8.5.2	TCR calculator	51
8.5.3	Low temperature OK threshold	51
8.5.4	High temperature OK threshold	51
8.5.5	Calibration temperature	51
8.5.6	Heating time limit	52
8.5.7	Measuring pulse duration	52
8.5.8	Data format	52
8.5.9	Automatic phase correction (AUTOCOMP)	52
8.5.10	Temperature diagnosis	54
8.5.11	Heatup timeout	55
8.5.12	Hold mode	55
8.5.13	Restart delay after reset	56
8.5.14	Maximum measurement pause	56
8.6	Webserver	57
8.6.1	Home	58
8.6.2	Status	59
8.6.3	Parameters/Counters	60

8.6.4	Protocol	61
8.6.5	Graphic	62
8.6.6	Calibration	63
8.7	Undervoltage detection	64
8.8	Analog temperature display	64
8.9	USB interface	65
8.10	AUX interface	65
8.11	Total cycle counter	65
8.12	Operating hours counter	66
8.13	Data memory	66
8.14	Built-in clock	66
9	Monitoring and error detection	68
9.1	System monitoring and alarm output	68
9.2	Error messages	69
9.2.1	Part 1 of 3: Troubleshooting	69
9.2.2	Part 2 of 3: Troubleshooting	71
9.2.3	Part 3 of 3: Troubleshooting	72
9.3	Fault areas and causes	73
10	Replacing heat-sealing band	75
10.1	Restarting device after changing heat-sealing band	75
11	Maintenance	76
12	Disposal	77
13	Technical data	78
13.1	Technical data	78
13.2	Modification	79
13.3	How to order	80
14	Declaration of Conformity	82
15	Appendix	84
15.1	Example of electrical cabinet wiring	85
15.2	Examples of electrical connections	86
	Index	91

1 Information on these operating instructions

1.1 Purpose of operating instructions

These operating instructions are a component of the product and provide information on the temperature controller RESISTRON® RES-5012.

They contain information on these and other topics:

- Assembly
- Installation
- Operation
- Maintenance

1.2 Target group

These instructions are intended to be used by qualified specialists.

1.3 Validity of the operating instructions

These instructions apply to all models of the temperature controller RESISTRON® RES-5012 manufactured September 2019 and later.

1.4 Related documents

- Data sheets and instructions for the line filters *LF-06480*, *LF-35480*, *LF-10520*, *LF-20520*, *LF-30520* and *LF-50520*
- Operating instructions for the current transformer *PEX-W5*
- Data sheet and manufacturer's documentation for the pulse transformer
- Your application report

1.4.1 Related software applications

- Operating instructions for the visualization software *ROPEXvisual*®
- Operating instructions for the application software *ROPEXupdate*

1.5 Storing documentation

- ▶ Keep these operating instructions for later reference.
- ▶ Ensure that all information and functions that the user may require are readily available.

1.6 Quality

For quality assurance purposes, the device is repeatedly inspected over the course of manufacturing. This ensures that the device leaves ROPEX in perfect condition.

1.7 Typography

These instructions apply the following typography rules:

Text	Product name and designation Example: <i>RES-5012</i>
	References to other documents Example: Refer to the <i>Application report</i> for more information.
"Text"	Composite terms and references to illustrations Examples: Position "0", thermal pre-treatment of heat-sealing band "burned in"
TEXT	Function Example: Activate AUTOCAL LED Example: LED AUTOCAL
Text	Menu item Example: Touch Update
	Key Example: Touch Manual key
	Bit Example: Bit Start
Text > Text	Menu path Example: Help > Supported devices
[▶ 24]	Reference to page number Example: Further information can be found in the section "Technical data" [▶ 24]
...	How to show "to" Example: The cold resistance of the heat-sealing band decreases to approx. 2...3 %.

Single-step instructions For single-step instructions or instructions where the chronology is not important, single-step instructions are used as follows:

- ✓ One or more prerequisites (optional) to be able to perform the next step.
- ▶ Step.

Multiple-step instructions For multiple-step instructions and instructions where the chronology is important, multiple-step instructions are used as follows:

- ✓ One or more prerequisites (optional) to be able to perform the next steps.
- 1. First step
 - ⇒ Intermediate result
- 2. Second step
 - ⚠ WARNING! Warning note as part of a step.**
 - ⇒ Result

2 Intended use

The device has been designed and tested in accordance with the latest state of technology. To prevent personal injury as well as damage to equipment, use the device properly and only as intended.

The temperature controller regulates the temperature of heat-sealing bands used to seal and cut thermoplastics.

The temperature controller may be operated only with suitable adhesives in a proper and complete control loop.

The device may be used only when it is completely assembled and is functioning as intended. The device may never be opened, repaired or modified in any way.

The device is developed, designed and built for industrial and commercial use only.

Personal use, e.g. in private households, is prohibited.

The device is intended to be used only by persons with the following knowledge and skills:

- Qualified technicians who, based on their professional training or experience, are familiar with pulse sealing.

Any other use besides the intended use is prohibited. The manufacturer will not be liable for damage resulting from unintended use. When any changes are made to the product, including in the course of assembly and installation, all warranty claims will be forfeited.

Consult all instructions and follow them carefully whenever working on the device.

2.1 Ambient conditions

Ambient conditions	Limits
Altitude	Up to 2000 m
Ambient temperature	+5...+45 °C
Maximum relative humidity	80 % at temperatures up to +31 °C decreasing linearly to 50 % relative humidity at +45 °C

3 Safety

3.1 Safety regulations

Always read the safety regulations carefully before using the device!

Install device Installation, startup and work on the device may be carried out only by qualified professionals. The persons must be familiar with the inherent dangers and warranty conditions.

- ▶ Install the device according to generally accepted engineering standards.

Preventing electric shock Line voltage is being applied to the electrical connections. This can cause electric shock.

- ▶ Before beginning any work, switch off the voltage supply and secure it to prevent it from being switched on again.
- ▶ Protect the device from humidity.

Requirements at installation site The device can malfunction or be damaged if the temperature is too high or too low, or if the humidity is too high.

- ▶ Install the device indoors in a dry room that is always frost-free.
- ▶ Never install the device outdoors.
- ▶ Comply with the ambient temperature indicated on the ID plate and in the applicable documentation.
- ▶ Protect the device from liquids and sustained high humidity. Never allow condensation to form in the device.
- ▶ Never cover the device with any objects.
- ▶ Comply with the specified minimum distance between devices.

Safe operation of the device

- ▶ Operate the device only fully assembled and installed.
- ▶ Make sure that the device is undamaged, complete and correctly assembled.
- ▶ In addition to these device instructions, observe the prohibition, warning and mandatory signs on the device.

3.2 How warnings are structured

These instructions contain various warnings of varying degrees, each preceded by a symbol or signal word. The symbol and the signal word indicate the hazard level.

How warnings are structured

Warnings that precede an action to be taken are shown as follows:



DANGER

Type and source of hazard

Explanation of type and source of hazard / description of consequences







- ▶ Measures to avert the hazard





Meaning of signal words

Signal	Definition
DANGER	Imminent risk of casualties or serious injury, if the hazard cannot be averted.
WARNING	Possible risk of serious injury, if the hazard cannot be averted.



Signal	Definition
CAUTION	Possible risk of minor injury, if the hazard cannot be averted.
NOTE	Property damage or malfunction, if the hazard cannot be averted.

Meaning of symbols

Symbol	Definition
	General indication of hazard
	Danger, high voltage
	Hazard of getting pulled in by moving parts
	Risk of injury to hands: squashing, puncture wounds
	Risk of burns: hot surfaces pose a hazard
	Note indicating potential property damage

Symbol	Definition
	General indication of hazard
	Danger, high voltage
	Fire hazard
	Note indicating potential property damage

3.3 Symbols on the device

Symbol	Definition
	<p>Conformity of the temperature controller is valid only when the device is used with the required components.</p> <p>Read the operating instructions thoroughly before using the device.</p> <p>Observe all warnings contained in the instructions.</p>
	Protective grounding to discharge transient overvoltage.
	Read the operating instructions thoroughly before using the device.

3.4 Conformity

We confirm as the manufacturer that this product has been developed and manufactured according to relevant standards and guidelines.

3.5 Rules

Comply with the following rules and regulations:

Legal requirements

- Statutory provisions regarding accident prevention
- Statutory provisions regarding environmental protection
- Occupational safety regulations

Standards and guidelines

Standards

- Applicable safety regulations required by DIN, EN and VDE
- DIN 46228 End sleeves
- DIN EN 60715:2018-07/VDE 0660-520:2018-07 Dimensions of low-voltage switchgear and controlgear - Standardized mounting on rails for mechanical support of switchgear, controlgear and accessories
- IEC 61010:2010 A1:2016 Safety requirements for electrical equipment for measurement, control, and laboratory use - Part 1: General requirements
- DIN EN 55011/VDE 0875-11 Industrial, scientific and medical equipment - Radio-frequency disturbance characteristics - Limits and methods of measurement
- DIN EN 55032:2016-02/VDE 0878-32:2016-02 Electromagnetic compatibility of multimedia equipment - Emission Requirements
- DIN EN IEC 61558-1/VDE 0570-1 Safety of transformers, reactors, power supply units and combinations thereof - Part 1: General requirements and tests (IEC 61558-1)
- DIN EN IEC 61784-2 Industrial communication networks - Profiles - Part 2: Additional field bus profiles for real-time networks based on ISO/IEC 8802-3
- DIN EN IEC 60947-1:2022-03/VDE 0660-100:2022-03 Low-voltage switchgear and control gear - Part 1: General rules

Directives

- 2014/30/EU Electromagnetic compatibility
- 2014/35/EU Low voltage
- 2011/65/EU Directive on the use of certain restricted substances in electrical and electronic equipment (RoHS directive).

3.6 Obligation of user

To ensure that the device functions properly, follow these instructions:

- To ensure safe operation, comply with the safety and warning notes contained in these instructions.
- Read the operating instructions thoroughly before using the device.
- Always operate the device in compliance with the conditions stated under "Technical Data."
- Store the operating instructions near the device.
- Only properly trained electricians may perform installation, startup and maintenance. Such persons are familiar with the equipment and the warranty conditions.

4 Description of project

4.1 Functioning

The temperature controller RESISTRON® *RES-5012* works in the control loop like this:

The resistance of the heat-sealing band changes along with the temperature of the heat-sealing band.

The resistance of the heat-sealing band is determined by measuring the current and voltage. This value is then used to calculate and display the actual temperature of the heat-sealing band, as well as to compare it to the specified setpoint.

The measurement is taken at a 50 Hz grid, corresponding to 50 times/second or a 60 Hz grid, corresponding to 60 times/second.

When the measurements deviate from the setpoint, the pulse transformer primary voltage is adjusted applying the phase angle principle. The resulting change of current in the heat-sealing band causes a temperature change, thus leading to a change in resistance. The temperature controller RESISTRON® *RES-5012* measures and evaluates the change in resistance. Based on the adjustment and the setpoint, the temperature controller RESISTRON® *RES-5012* adjusts the control variables.

Even the smallest thermal loads are detected by the heat-sealing band and can be quickly and precisely corrected. The measurement of purely electrical variables and the high measuring rate create a highly dynamic, thermo-electrical control loop. The principle of primary transformer control has proven particularly beneficial - it enables a wide range of secondary current with only minimal power dissipation. This facilitates optimal adaptation to the load and to the desired dynamic, even when the device is compact.

4.2 Application

The temperature controller RESISTRON® *RES-5012* is part of the series 5000.

The temperature controller RESISTRON® *RES-5012* is used to regulate the temperature of heat-sealing bands used to seal and cut thermoplastics. The temperature controller can also be used for other sealing work, such as controlling hot air applications.

4.3 Properties

The temperature controller RESISTRON® *RES-5012* is equipped with a EtherCAT® interface. Through this interface, all functions and parameters can be set by means of the higher-level machine controller. In addition, essential temperature controller information is queried and can be processed accordingly.

Actual temperature The ACTUAL temperature of the heat-sealing band is output as follows:

- EtherCAT® interface
- Analog output 0...10 VDC
- Visualization software
- Webserver

Heating element alloy and temperature range Adjustments for different heat-sealing band alloys and setting of the temperature range can be done through coding switches on the temperature controller itself or through the EtherCAT® interface.

Error diagnosis The temperature controller RESISTRON® *RES-5012* has an integrated error diagnosis feature. Error diagnosis examines both the outer system, e.g. heat-sealing band and wiring, and the internal electronic elements. A differentiated error message is output through the EtherCAT® interface in the event of malfunction.

Operational safety To improve operation safety and immunity to interference, all EtherCAT® signals from the temperature controller and the heat-sealing band are electrically isolated.

Modification There is an optional device modification available, e.g. for use with very short or low-resistance heating-sealing bands.

Other functions Some of the features and functions:

- Easy calibration of the heating element through AUTOCAL, the automatic zero-point setting.
- Eight channels permit switching of the calibration parameters during tool change.
- High control dynamics through AUTOTUNE, automatic adjustment to the controlled system
- High flexibility with the AUTORANGE feature.
The AUTORANGE feature covers a secondary voltage range of 0.4 V to 120 V and a current range of 30 A to 500 A.
- Automatic adjustment of the line frequency.
- Wide voltage range for flexible use (Limits can be found on the ID plate).
- Easy and convenient system diagnosis and process visualization with the *ROPEXvisual*[®] software.
- Booster output available for connecting a booster.
- Process reliability due to comprehensive options for evaluating parameter data, e.g.
 - Temperature diagnosis
 - Heat-up time monitoring

Additional information can be found in the sections ID plate [▶ 16] and Technical data [▶ 78].

4.4 Overview

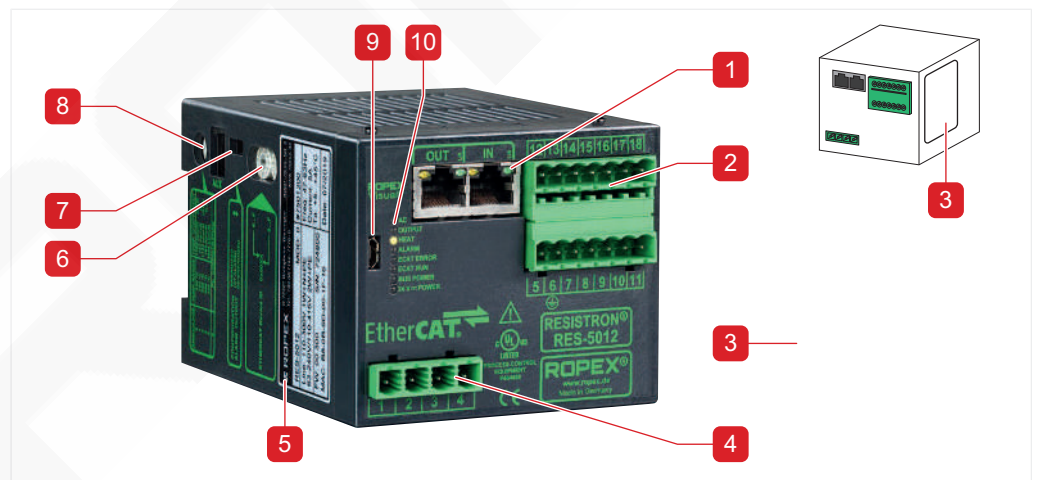

Illustration 1: Overview of temperature controller RES-5012

1	EtherCAT [®] ports	2	Terminals 5 to 18
3	Terminal diagram	4	Terminals 1 to 4
5	ID plate	6	Device ID
7	Alarm relay slide	8	Coding dial, temperature range and alloy
9	USB port	10	LEDs

4.4.1 ID plate

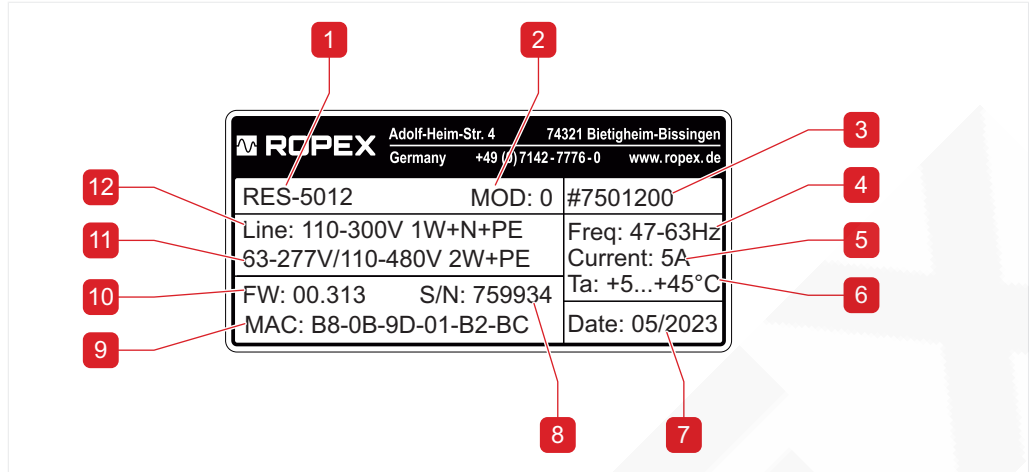

Illustration 2: ID plate temperature controller RES-5012, example

1	Temperature controller RES-5012	2	Modification
3	Article number	4	Frequency
5	Continuous current	6	Ambient temperature
7	Manufacturing date	8	Serial number
9	MAC address	10	Firmware version
11	Line voltage / connection, two-phase	12	Line voltage / connection, single-phase

The ID plate is located on the side of the device.

4.4.2 Dimensions

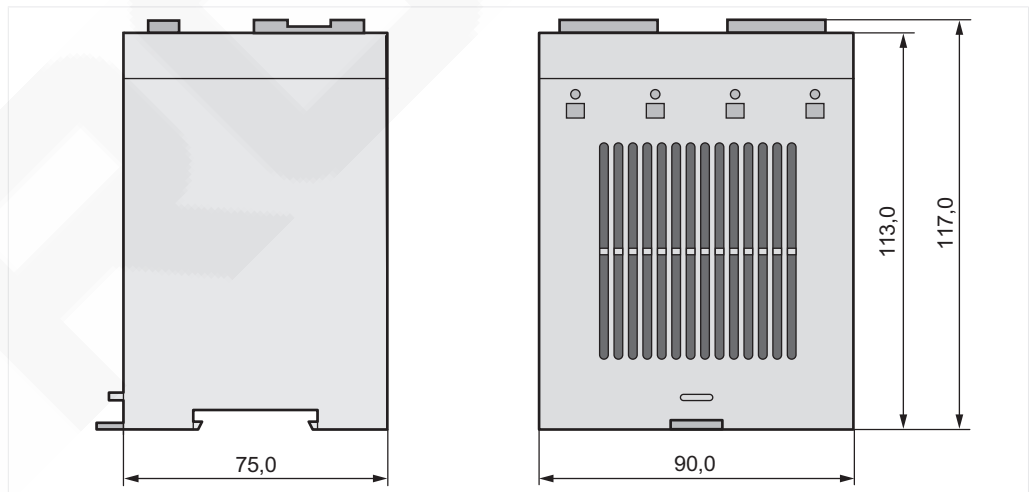

Illustration 3: Dimensions in mm (without terminals)

4.5 Essential system components

4.5.1 Control loop components

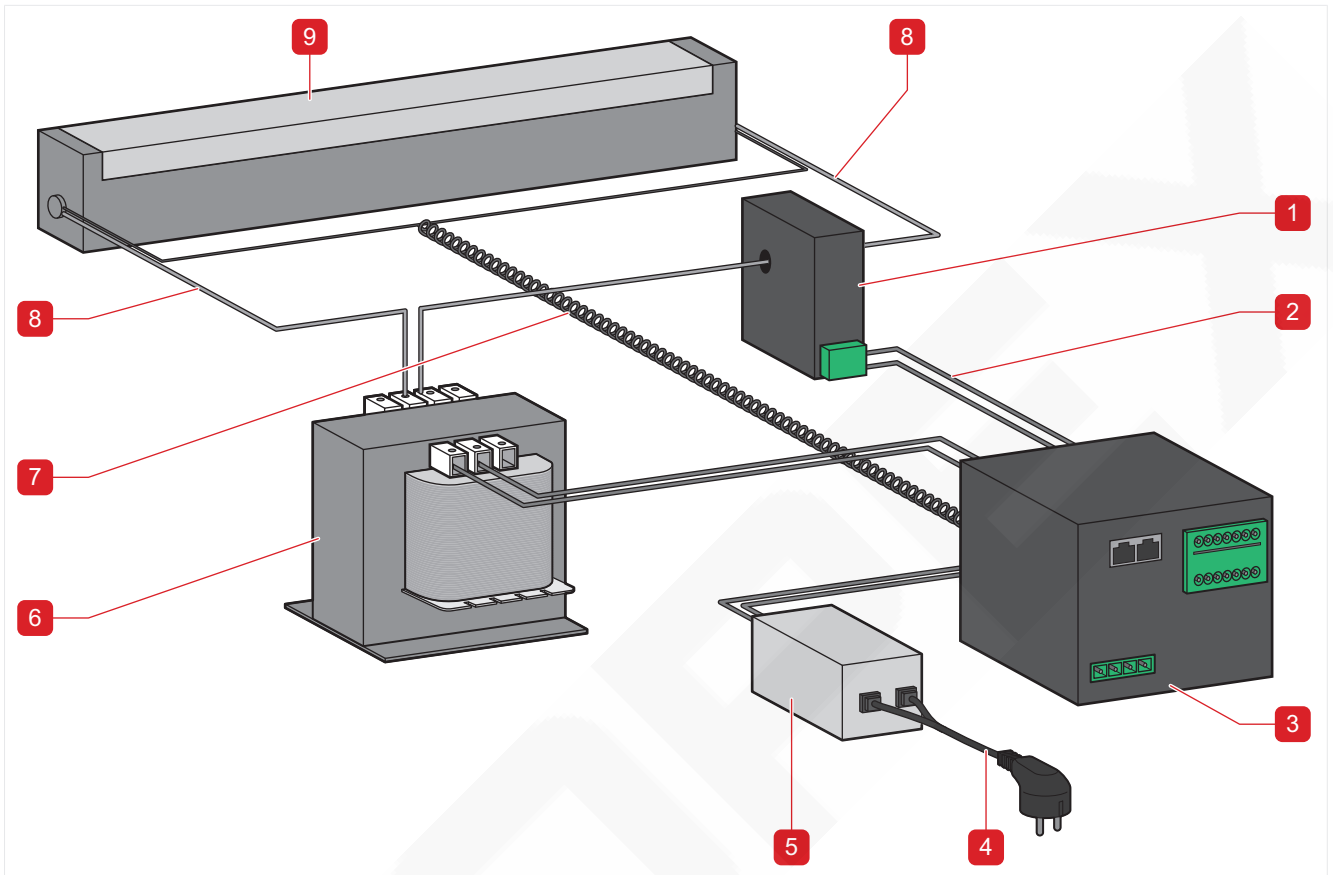

Illustration 4: Control loop components (diagram)

Pos.	Component	Other notes and requirements
1	Current transformer	Refer to section Current transformer [▶ 19]
2	Measurement cable, current I_R	
3	Temperature controller	
4	Power supply	
5	Line filter	Refer to section Line filters [▶ 20]
6	Pulse transformer	Refer to section Pulse transformer [▶ 19]
7	Measurement cable, U_R	Refer to section Measurement cable [▶ 20]
8	Secondary circuit lines	
9	Sealing bar with heat-sealing band	Refer to section Heat-sealing band [▶ 18]

Note The application report is needed to position and determine the essential components.

4.5.2 Heat-sealing band



⚠ DANGER

Fire hazard due to overheating of heat-sealing band

A defect in the control loop can cause the heat-sealing band to overheat and components to catch fire.

- ▶ Attach a contactor Kb to the heat-sealing band.
- ▶ Install a temperature monitor at the heat-sealing band.



⚠ DANGER

Fire hazard due to unsuitable heat-sealing bands

An unsuitable heat-sealing band can overheat and cause components to catch fire.

- ▶ Use only heat-sealing bands intended specifically for this purpose.
- ▶ Comply with the application report.

Unsuitable heat-sealing bands

Low-ohm heat-sealing bands, e.g. NiCr 80/20, are **not** suitable for use with the temperature controller RESISTRON® RES-5012.

Heat-sealing band ends

The ends of heat-sealing bands can be coated, e.g. with copper or silver. Coating the ends of the heat-sealing bands changes the electrical properties. The ends remain cold, and more direct temperature control is then possible in the active zone. Coating also extends their serviceable life.

Temperature coefficient

Always use a heat-sealing band with a positive temperature coefficient in order to guarantee trouble-free operation of the temperature controller RESISTRON® RES-5012.

Example

Heat-sealing band alloy	Unit	Temperature coefficient (TCR)
Alloy 20	ppm/K	1100
Alloy L	ppm/K	780
LEX3500	ppm/K	3500

The temperature controller RESISTRON® RES-5012 has to be set and coded according to the temperature coefficient of the heat-sealing band.

The temperature coefficient can be found in your application report.

Notes

- The measurement principle requires a unique temperature coefficient (TCR) of the heat-sealing alloy.
- If the temperature coefficient of the heat-sealing band is greater than the set value, the actual temperature is lower than the displayed temperature. But if the temperature coefficient of the heat-sealing band is less than the set value, the actual temperature is higher than the displayed temperature.
- The resistance value rises as the heat-sealing band gets warmer. If the temperature coefficient of the heat-sealing band is below the permitted range, the control loop can fluctuate or the heat-sealing band can overheat.

Assembly and installation

The following are important for the assembly and installation of the heat-sealing bands:

Parallel connection of heat-sealing bands

To ensure that the temperature of both heat-sealing bands is the same, cables of the same length and same cross-section have to be used.

Examples of parallel connection can be found in section Appendix [▶ 84].

Series connection of heat-sealing bands To prevent overcurrent and consequential spot overheating when heating the heat-sealing band, the heat-sealing bands may not touch one another.
Examples of series connection can be found in section Appendix [► 84].

4.5.3 Pulse transformer



⚠ DANGER

Danger, high voltage and overheating

Incorrect assembly and installation of the pulse transformer impair electrical safety.

- ▶ Install touch protection.
- ▶ Select the proper cable cross-section.
- ▶ Comply with the application report.

The pulse transformer is a component of the control loop. It is attached between the temperature controller and the voltage supply connection to the heat-sealing band. The pulse transformer supplies the voltage required by the heat-sealing band and is designed for the individual application; refer to the application report.

The following requirements have to be met:

- The dimensions of the pulse transformer should be suitable for the control loop.
 - Primary and secondary voltage
 - Output
 - Duty cycle of transformer
- This transformer must be designed according to EN 61558 or UL 5085 (isolating transformer with reinforced insulation)
- Single-chamber model

Assembly and installation

The following are important for the assembly and installation of the pulse transformer:

- The touch protection must comply with national and installation requirements.
- Use the cable cross-sections stated in the application report.
- Clamp the the cables to the pulse transformer terminals. Check the terminals regularly to ensure that they are mounted tightly.

4.5.4 Current transformer



NOTICE

Malfunction due to use of devices from other manufacturers

Devices from other manufacturers can lead to malfunctions in the control loop.

- ▶ Use only original ROPEX current transformers or ROPEX monitoring current transformers.

The current transformer is a component of the control loop. It may be used only to measure the current, enabling the temperature controller to determine the heat-sealing band temperature.

Observe the following notes and comments:

- The current transformer may be started up only when it is properly connected to the temperature controller; refer to section Connection diagram [► 26].

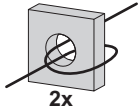

- If the secondary peak current I_2 is less than 30 A, the secondary high-current wire must be laid through the current transformer at least twice; refer to the application report.
- If the cross-section is too large or the insulation too thick, use an *HCB-1* high-current rail to route the cable through the current converter. Further information can be found in the respective operating instructions.
- ROPEX monitoring assemblies such as the Current Balance Monitor *CBM-2* can be used to increase operating safety. Further information can be found in the respective operating instructions.
- External monitoring assemblies such as insulation monitors or a voltage monitoring device can also be used. Refer to the manufacturer's operating instructions for more information.

4.5.5 Line filters

CE conformity of the temperature controller can only be achieved with the line filters recommended and supplied by ROPEX. The line filters damp the reaction of the phase-angle control on the line and protect the temperature controller against line disturbances.

Observe the following notes and comments:

- ▶ Always use a ROPEX line filter.
- ▶ Install unfiltered and filtered lines in separate wiring ducts.
- ▶ Follow the instructions in the line filter operating instructions.
- ▶ Comply with the application report.

4.5.6 Measurement cable

Use a twisted measurement cable supplied by ROPEX (*UML-1* or *UML-2*). Connect the measurement cable directly to the clamping head on the sealing bar.

The measurement cables *UML-1* and *UML-2* are twisted cables used for voltage measurement in conjunction with RESISTRON® and CIRUS® temperature controllers.

Further information can be found on the measurement cable data sheet.

4.6 Optional system components

4.6.1 Booster

If the continuous current is greater than 5 A or the pulsed current is greater than 25 A, use a booster; refer to section How to order [▶ 80]. Refer to the application report for more detailed information.

5 Assembly and installation

5.1 Transporting and checking device

To prevent damage, always transport and store the device in the original box.
After transporting the device, visually inspect the device for any damage.

5.2 Scope of delivery

Check the delivery for damage and verify that it is complete.

Delivery includes:

- Temperature controller with terminal strips in place.

5.3 Installation site requirements

Installation site



NOTICE

Liquids and dust can damage the equipment

Liquids and dust that penetrate the device can impair proper functioning. Electrical components can become corroded.

- ▶ Set up and operate the device only in a clean, dust-free environment.
- ▶ Protect the device from moisture, water, cleaning solutions and conductive liquids.
- ▶ Ensure that the area is well ventilated.

The installation site must be dry and frost-free at all times.

Machine-side supply voltage



NOTICE

Equipment damage caused by incorrect supply voltage

Supply voltage that is too high or too low can damage the device.

- ▶ Adjust the machine-side supply voltage to suit the permitted voltage and frequency range of the temperature controller.
- ▶ Observe the information on the ID plate.

5.4 Device assembly

Observe this warning before beginning any work on the system:



⚠ DANGER

Risk of death by electric shock

There is dangerous voltage at the electrical connections to the temperature controller, the system components and the heat-sealing bar.

- ▶ Electrical installation may be performed only by qualified electricians.
- ▶ Switch off the voltage supply or line voltage.
- ▶ Secure to prevent it from being switched on again.
- ▶ Verify that there is no voltage being supplied.

Access to coding dial

Tip If the temperature controller is to be configured using the coding dials, switch on the dial before attaching the temperature controller to the top hat rail. Refer to section Temperature controller configuration [▶ 32] for further information. Once the temperature controller is attached to the top hat rail it is difficult to access the coding dial.

To attach the temperature controller, proceed as follows:

Prerequisite

- ✓ Line voltage and the 24 VDC supply voltage are switched off and secured from being switched on again.
1. Verify that the circuit is de-energized.
 2. Attach the temperature controller to a top hat rail TS35 (DIN EN 50022) in the electrical cabinet.
The moving clip required for fastening faces down for mounting on a horizontal top hat rail.
End holders to mechanically fix the device must be fitted at both ends.
 3. A minimum safety clearance of 20 mm all round (e.g. from other devices and wiring) must be allowed when installing the device.

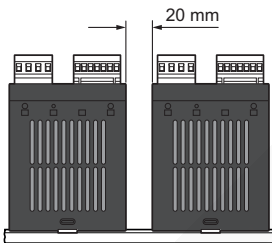

Example of installation in electrical cabinet

An example of the layout and wiring of system components can be found in the Appendix [▶ 84].

5.5 Installation of device



⚠ DANGER

Risk of death by electric shock

There is dangerous voltage at the electrical connections to the temperature controller, the system components and the heat-sealing bar.

- ▶ Electrical installation may be performed only by qualified electricians.
- ▶ Switch off the voltage supply or line voltage.
- ▶ Secure to prevent it from being switched on again.
- ▶ Verify that there is no voltage being supplied.

Proceed as follows to install the temperature controller:

- Prerequisite**
- ✓ Line voltage and the 24 VDC supply voltage are switched off and secured from being switched on again.
 - ✓ Installation of the temperature controller is completed.
1. Completely wire the system; refer to section Rules [▶ 12], section Power supply [▶ 24], section Connection diagram [▶ 26], section Control loop components [▶ 17] and to the application report.
 Note: Wires used for control or measuring connections must always be laid inside the building.
 2. Check that the wiring complies with applicable national and international installation requirements.
 3. An overcurrent protective device with a maximum rating of 10 A must be installed¹⁾.
 - ⇒ If one such device is not adequate for the heat-sealing application, two separate overcurrent protective devices should be provided – one for the temperature controller and one for the sealing application: refer to the application report.
 The overcurrent protective device must be located directly adjacent to the device.
 The minimum possible specification for this device based on the calculated currents is indicated in the application report. If a larger overcurrent protective device is fitted, match the current carrying capacity of the other components accordingly (e.g. cables, pulse transformer, etc.).
 4. Provide a disconnecting device when the system is installed; it must be marked as belonging to the system and placed in a readily accessible position.
 If a circuit breaker is used, it can also perform the function of this device.
 5. Check all of the terminals in the system to ensure that they are mounted tightly, including the terminals for the pulse transformer windings.

- Notes**
- The control loop can function properly only when the system components are the right size. Refer to the application report for more information.
 - To ensure proper and stable control, do **not** install additional resistance in the secondary circuit. Additional resistance in the secondary circuit, e.g. circuit breakers, long lines, plug connections, etc. have an impact on control and can cause the system to malfunction.

¹⁾ Examples:

- Circuit breaker pursuant to EN 60898 (characteristic B, C, D, K or Z)
- Circuit breaker pursuant to UL 489 (characteristic B, C, D, K or Z)
- Fuse gG pursuant to IEC 60269
- Fuse "class CC" or "Class JJ pursuant to UL 248

5.5.1 Power supply

The following illustration shows a standard application.

When making electrical connections, also refer to the section Connection diagram [► 26] as well as to the application report.

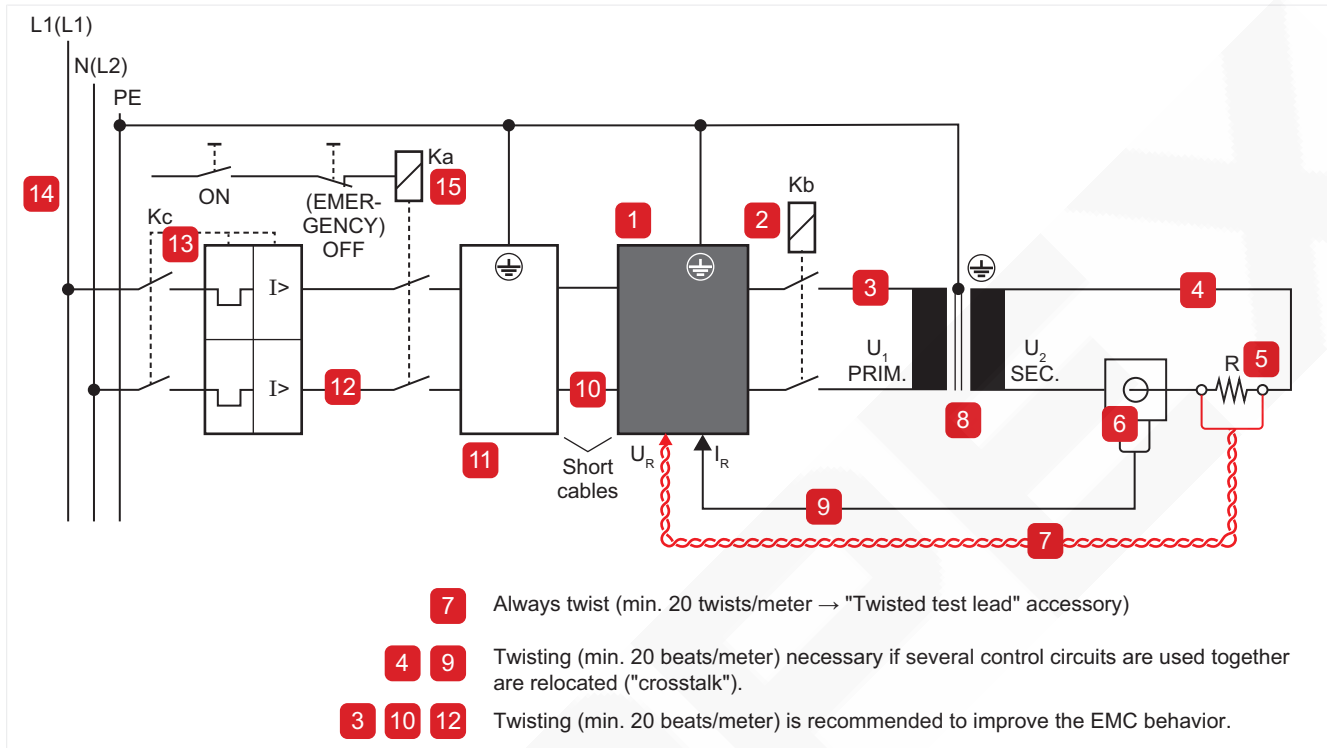

Pos.	Component	Notes and requirements
1	Temperature controller	
2	Contactors Kb	To increase the safety of machine operation, refer to the section Contactors Kb [► 25].
3	Primary pulse transformer lines	Refer to the application report.
4	Secondary line	Heat-sealing band connection to the pulse transformer. Use high-quality connecting elements that ensure low contact resistance with long-term stability. Refer to the application report.
5	Heat-sealing band	Refer to section Heat-sealing band [► 18] and to the application report.
6	Current transformer	NOTICE! Observe the number of ducts for passing the secondary cable through the current transformer. Refer to section Current transformer [► 19] and to the application report.
7	Measurement cable U_R	NOTICE! Use twisted measuring cables provided by ROPEX. NOTICE! Input voltage max. 120 V. Refer to section Measurement cable [► 20] and to the application report.
8	Pulse transformer	Refer to section Pulse transformer [► 19] and to the application report.

Pos.	Component	Notes and requirements
9	Measurement cable, current I_R	<p>! NOTICE! Use twisted measuring cables provided by ROPEX.</p> <p>Refer to section Measurement cable [► 20] and to the application report.</p>
10	Filtered lines (lines between line filter and temperature controller)	Refer to the application report.
11	Line filters	<p>Do not install unfiltered and filtered lines in the same wiring ducts.</p> <p>Refer to section Line filters [► 20] and to the application report.</p>
12	Unfiltered lines (lines between voltage supply and line filter)	Refer to the application report.
13	Overcurrent protective device K_c	<p>Example: 2-pin circuit breaker or fuse; refer to the application report.</p> <p>! NOTICE! Protects only from short-circuit. Does not protect the temperature controller.</p>
14	Grid	To improve the immunity to interference, the system can be connected to the same phase when the output is low. Observe the requirements specified by the electric company in regard to a symmetrical grid load.
15	Contacteur K_b	For EMERGENCY OFF or EMERGENCY STOP (all-pole)

5.5.1.1 Contactor K_b

A contactor K_b can be installed in the control loop to increase the safety of the machine.

The contactor K_b causes load break (all-pole), e.g. in conjunction with the alarm output of the temperature controller

A contactor K_b can also be installed in the control loop, e.g. when the system has to be switched off by the machine controller (PLC) or when a door contact is required.

The load on the contactor K_b is a factor of the specific application; refer to the application report.

Tips Trigger the contactor K_b via the temperature controller alarm relay.

- To do this, set the alarm output to inverse ("de-energized at alarm") and connect the 24 VDC supply voltage for the contactor to the NO and C contacts of the alarm relay.

To prevent errors, first switch on the 24 VDC supply voltage before the temperature controller receives a RESET signal.

5.5.2 Connection diagram

Additional protective equipment as well as the controller for the equipment should be provided on site.

When making electrical connections, also refer to the section Power supply [▶ 24] as well as to the application report.

The following illustrations show examples of standard applications.

Connection diagram for system without booster

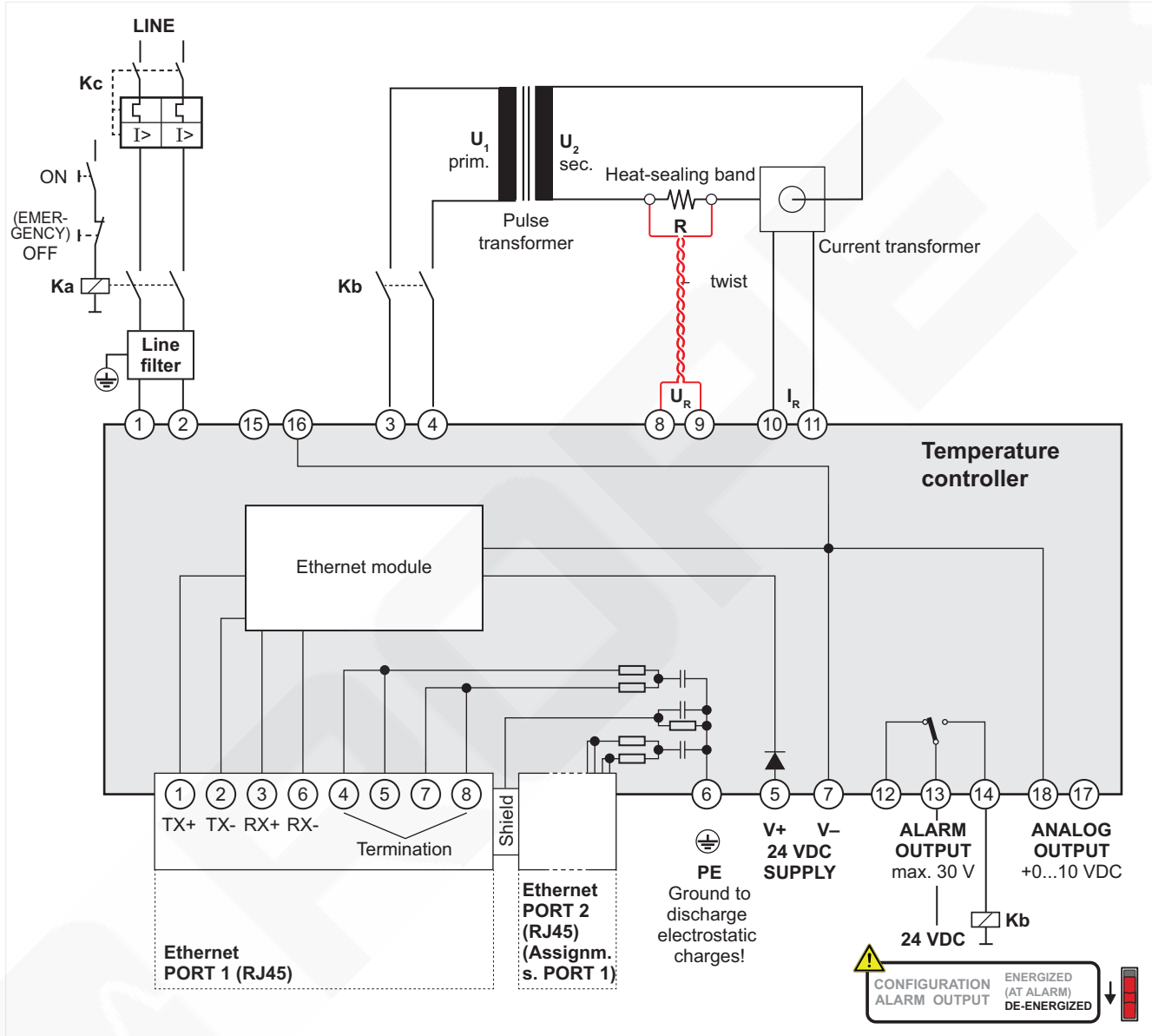

Illustration 5: Connection diagram, example of system without booster

Connection diagram for system with booster



NOTICE

Electromagnetic compatibility disruption as a result of cables that are too long

If the lines to the external booster are too long or the wires are not twisted, errors can occur when triggering the pulse transformer.

- ▶ The connecting line should be no longer than 1 m.
- ▶ Twist the wires.

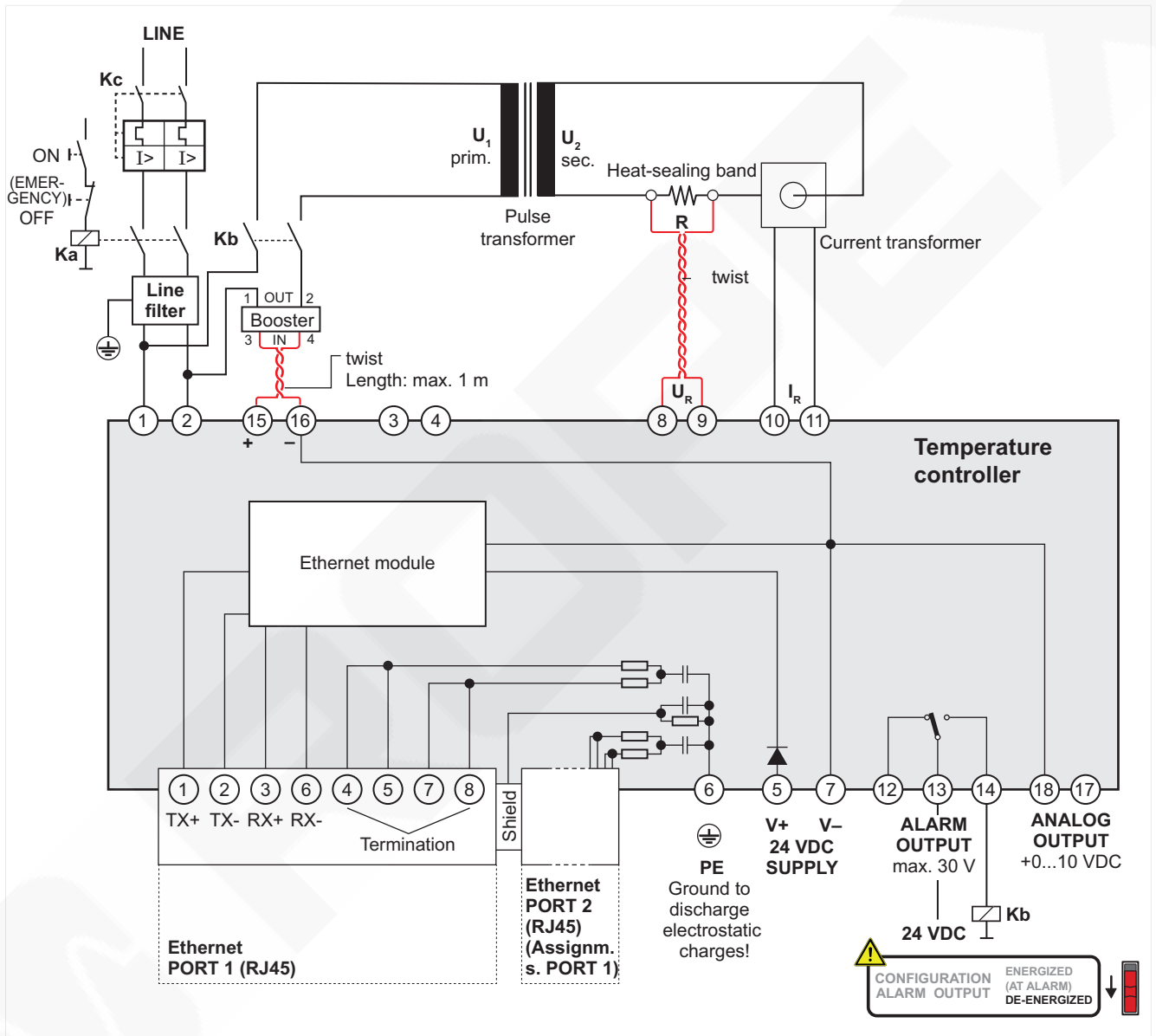

Illustration 6: Connection diagram, example of system with booster

Observe booster polarity

- ▶ Connect the booster to terminals 15 and 16.
- Connect the booster terminal 3 to the temperature controller terminal 15
- Connect booster terminal 4 to the temperature controller terminal 16

Wiring in electrical cabinet

An example of the layout and wiring of system components in the electrical cabinet can be found in the appendix under Example of electrical cabinet wiring [▶ 85].

6 Startup



NOTICE

Malfunctioning due to use of devices from other manufacturers

Devices from other manufacturers can lead to malfunctions in the control loop.











- ▶ Use only original ROPEX accessories.
- ▶ Use only system components manufactured by ROPEX or that are approved for use with ROPEX equipment.











Proceed as follows to start up the temperature controller:

6.1 Initial startup

Prerequisites The following requirements have to be met:

- The device is completely assembled; refer to section Device assembly [▶ 22].
- The device is completely connected; refer to section Installation of device [▶ 22].
- Line voltage and 24 VDC supply voltage are switched off.
- Confirmation that equipment is de-energized.
- Heat-sealing band is cold.

	Startup step		Reaction of temperature controller
1.	Set the last two positions of the device ID with the coding dial; refer to section Setting coding dials for device ID [▶ 33].		
2.	Integrate the ESI file into the hardware configuration tool and then set the desired parameters.		
3.	Switch on the 24 VDC supply voltage.		AC flickers or flashes briefly, indicating that switchon has been done correctly.
			BUS POWER illuminated
			24 VDC POWER illuminated
4.	After successful switchon.		AC flashes slowly (1 Hz)
			BUS POWER illuminated
			24 VDC POWER illuminated
5.	Use the hardware configuration tool to establish connections and start EtherCAT® communication.		
6.	Start the higher-level controller EtherCAT® master and ensure that it sends only zero values to the temperature controller.		AC flashes slowly (1 Hz)
			ECAT RUN lights up as soon as the connection has been established.
			BUS POWER illuminated
			24 VDC POWER illuminated
7.	Switch on line voltage.		AC goes off

Startup step		Reaction of temperature controller	
7.	Switch on line voltage.		ALARM flashes quickly (4 Hz), if AUTOCAL is necessary ³⁾
			ECAT RUN illuminated
			BUS POWER illuminated
			24 VDC POWER illuminated
8.	Activate the AUTOCAL feature: ► In the EtherCAT® protocol, set the AC bit (AUTOCAL); refer to section Automatic zero calibration AUTOCAL (AC) [► 39].		AC illuminated for the duration of calibration (approx. 10...15 seconds).
			ALARM goes off
		The AA bit is set during this process (AUTOCAL active), and at the actual value output (terminals 17+18), there is voltage of approx. 0 VDC. If an analog temperature display is connected, it shows 0...3 °C.	
9.	When the AA bit is active, reset the AC bit.	If the AC bit is not reset, AC continues to flash quickly, even if the function AUTOCAL has been completed successfully. The function AUTOCAL is requested but cannot be executed.	
10.	Check whether zero calibration was successful.	Zero calibration was successful:	
		The AA bit is deleted again (AUTOCAL active).	
			AC goes off
		Voltage of 0.66 VDC automatically sets at the actual value output (at the 300 °C range and temperature AUTOCAL = 20 °C) or 0.4 VDC (at the 500 °C range).	
		Zero calibration failed:	
		The AL bit has been set (ALARM active) ⁴⁾	
	ALARM flashes slowly (1 Hz)	The temperature controller is not configured properly; refer to Error messages [► 69]. Repeat zero calibration.	
11.	Check heatup and control function: 1. Via the network protocol, specify a defined temperature (setpoint) and set the ST bit. 2. Read out the temperature via the analog output or the actual value in the network protocol, and check the course of the temperature.		HEAT illuminated.
			OUTPUT illuminated analog to the phase-angle control. The heat-sealing band warms up.
		The RA bit (Regelung aktiv , controller active) is active.	

³ AUTOCAL may be required even if ALARM is not flashing quickly.

⁴ The WA bit can also be active.











	Startup step	Reaction of temperature controller
12.	When the heat-sealing band is not burned in: ► Burn in the heat-sealing band; refer to section Burning in heat-sealing band [► 34].	
	The temperature controller is ready.	





6.2 Restarting device

The system has to be restarted when any changes are made, e.g. replacement of the heat-sealing band.

Prerequisites The following requirements have to be met:

- The device is completely assembled; refer to section Device assembly [► 22].
- The device is completely connected; refer to section Installation of device [► 22].
- Line voltage and 24 VDC supply voltage are switched off.
- Confirmation that equipment is de-energized.
- Heat-sealing band is cold.



	Startup step	Reaction of temperature controller	
1.	Switch on the 24 VDC supply voltage. Start the higher-level controller and check that all of the control bits are set to "0".		AC flickers or flashes briefly, indicating that switchon has been done correctly.
			BUS POWER illuminated
			24 VDC POWER illuminated
2.	AC flashes slowly after the switchon process.		AC flashes slowly (1 Hz)
			ECAT RUN lights up as soon as the connection has been established.
3.	Switch on line voltage.		AC goes off
			ALARM flashes quickly (4 Hz), if AUTOCAL is necessary
			ECAT RUN illuminated
4.	Activate the AUTOCAL feature: ► In the EtherCAT® protocol, set the AC bit (AUTOCAL); refer to section Automatic zero calibration AUTOCAL (AC) [► 39].		AC is illuminated for the duration of calibration (approx. 10...15 seconds).
			ALARM goes off
		The AA bit is set during this process (AUTOCAL active), and at the actual value output (terminals 17+18), there is voltage of approx. 0 VDC. If an analog temperature display is connected, it shows 0...3 °C.	
5.	When the AA bit is active, reset the AC bit.	If the AC bit is not reset, AC continues to flash quickly, even if the function AUTOCAL has been completed successfully. The function AUTOCAL is requested but cannot be executed.	
6.	Check whether zero calibration was successful.	Zero calibration was successful: The AA bit is deleted again (AUTOCAL active).	

Startup step		Reaction of temperature controller	
6.	Check whether zero calibration was successful.		AC goes off
		Voltage of 0.66 VDC automatically sets at the actual value output (at the 300 °C range and temperature AUTOCAL = 20 °C) or 0.4 VDC (at the 500 °C range).	
		Zero calibration failed: The AL bit has been set (ALARM active) ⁵⁾	
			ALARM flashes slowly (1 Hz)
		The temperature controller is not configured properly; refer to section Error messages [▶ 69]. Repeat zero calibration.	
7.	Check heatup and control function: 1. Via the network protocol, specify a defined temperature (setpoint) and set the ST bit. 2. Read out the temperature via the analog output or the actual value in the network protocol, and check the course of the temperature.		HEAT illuminated.
			OUTPUT illuminated analog to the phase-angle control. The heat-sealing band warms up.
		The RA bit (R egelung a ktiv, controller active) is active.	
8.	When the heat-sealing band is not burned in: ▶ Burn in the heat-sealing band; refer to section Burning in heat-sealing band [▶ 34].		
The temperature controller is ready.			







6.3 LED behavior upon startup

During startup, the LEDs can behave as follows:

("O" means that the LED is off)

LED AUTOCAL	LED ALARM	LED OUTPUT	Causes and measures
Beginning FW 314: Flickers 2 s and flashes briefly 	O	O	Boot loader starts. Switchon was done properly ▶ Continue startup
Beginning FW 314: Flashes briefly 	O	O	Switchon was done properly ▶ Continue startup

⁵⁾ The WA bit can also be active.

LED AUTOCAL	LED ALARM	LED OUTPUT	Causes and measures
Flashes briefly 	Flashes slowly (1 Hz) 	○	Configuration has been changed. 1. Check temperature controller configuration. 2. Perform AUTOCAL again.
Flashes slowly (1 Hz) 	○	○	No line voltage being applied. ► Switch on line voltage.
Flickers 2 s and flashes briefly, repetitively 	○	○	The 24 VDC supply voltage is too low or not stable. ► Check the 24 VDC supply voltage.
○	○	Brief pulses every 1.2 s 	Continue startup
○	FLASHES quickly (4 Hz) 	○	Continue startup
○	Remains ON 	○	For error diagnosis, refer to Error messages [► 69].

Further information on LED behavior can be found in section Display and operating elements [► 36].

6.4 Temperature controller configuration



⚠ WARNING

Danger, supply voltage at device

Line voltage is being applied to the electrical connections on the device.

- Electrical installation may be performed only by qualified electricians.
- Switch off the current supply.
- Secure the current supply to prevent it from being switched on again.

Prerequisite

- The temperature controller is voltage-free.

6.4.1 Current transformer configuration

Configuration of the current transformer for the secondary peak current is set within the range 30...500 A.

When the secondary current I_2 is set to less than 30 A, check that the secondary high-current wire has been laid at least twice through the current converter; refer to the application report.

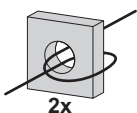

6.4.2 Setting coding dial for temperature range and alloy



DANGER

Fire hazard due to uncontrolled heatup

Using alloys with temperature coefficients that are too low or incorrect coding of the temperature controller cause uncontrolled heatup. The heat-sealing band can burn up.

- ▶ Use a heat-sealing band with the proper temperature coefficient.
- ▶ Set the correct temperature coefficient in the temperature controller.
- ▶ Set the correct temperature range in the temperature controller.

Use the coding dial to adapt the temperature to the heat-sealing band alloy and the desired sealing temperature range.



Illustration 7: Position of coding dial for temperature range and alloy

Coding dial position	Temperature range 0...x°C	Temperature coefficient (TCR)	Example of heat-sealing band alloy
0 (default)	300 °C	1100 ppm/K	Alloy 20
1	300 °C	780 ppm/K	Alloy L
4	500 °C	1100 ppm/K	Alloy 20
5	500 °C	780 ppm/K	Alloy L
8	300 °C	3500 ppm/K	LEX3500
9	▶ Set the parameters in the visualization software.		

- Notes**
- Select dial position "9" to access other temperature ranges and alloys via the visualization software. Information on this topic can be found in section USB interface [▶ 65] and in the operating instructions for the software *ROPEXvisual*®.
 - The higher-level controller transmits the parameter data to the temperature controller. This can overwrite the coding dial setting for the temperature range and alloy. Check the coding dial setting. Refer to section Temperature range and alloy [▶ 50] for further information.

6.4.3 Setting coding dials for device ID

Use the two coding dials to set the last two positions of the ID device of the temperature controller.

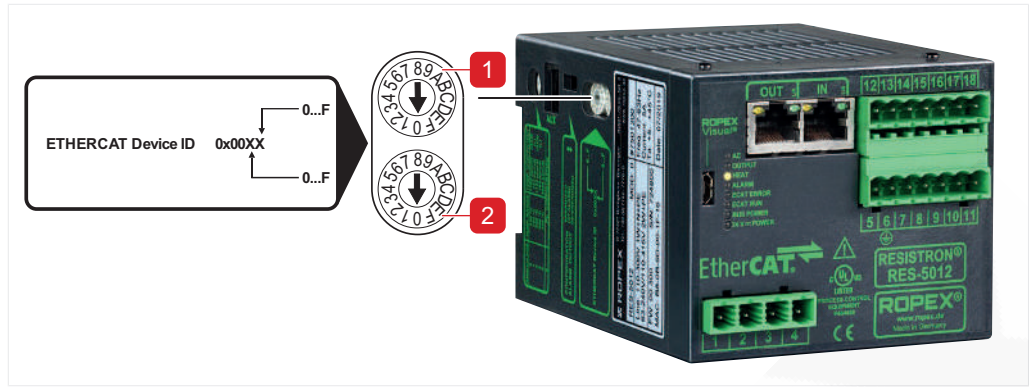

Coding dial	Setting range	Adjustable byte of device ID	Default
1	0...F	0x000 <u>0</u>	0
2	0...F	0x00 <u>0</u> 0	0

The temperature controller evaluates the coding dial for device ID during operation. Changes to the device ID take effect approx. 3 seconds after switching.

6.4.4 Alarm relay configuration

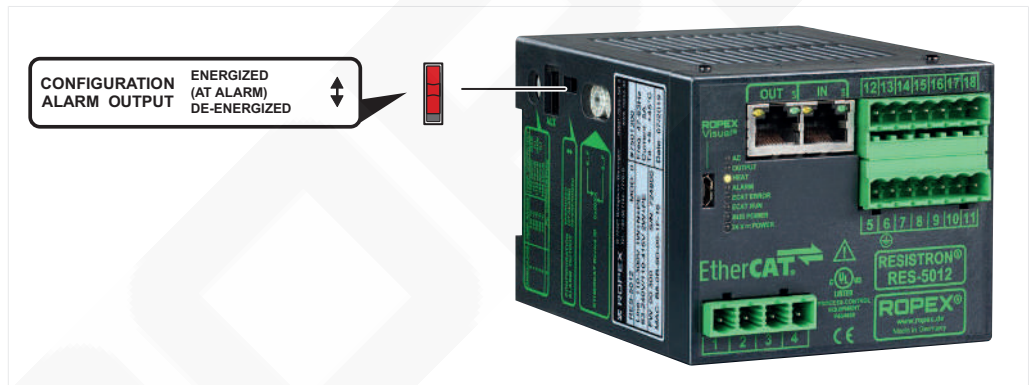

Illustration 8: Alarm relay configuration

Slide switch position	Meaning
	ENERGIZED: Alarm relay contact closed by alarm (default)
	De-ENERGIZED: Alarm relay contact opened by alarm

6.5 Burning in heat-sealing band

Burning-in effect The first time the heat-sealing band is heated, some alloys undergo a one-time change in the material properties.

Consequences:

- The electrical properties of the heat-sealing band may change.
- This causes the displayed temperature of the cooled heat-sealing band to change.

Remedy:

- Burn in heat-sealing band.

Burning-in process



CAUTION

Hot surfaces pose a risk of burns

The surface of the heat-sealing band as well as the sealing bars get very hot during operation.

- ▶ Install touch protection.



CAUTION

Moving parts pose a risk of crushing

When the sealing bars move during operation, there is a risk of getting trapped.

- ▶ Install appropriate protective measures, e.g. monitoring sensors.
- ▶ Install touch protection.

To burn in the heat-sealing band, proceed as follows:

Prerequisite

- ✓ The sealing bars are open.
- 1. Perform AUTOCAL; refer to section Automatic zero calibration AUTOCAL (AC) [▶ 39].
 - ⇒ The temperature controller calibrates itself to the cold resistance of the heat-sealing band.
- 2. Heat the heat-sealing band to 250 °C (at least 50 °C above the sealing temperature as a factor of the application).
- 3. Once the setpoint temperature has been reached, maintain it for 3 s.
 - ⇒ The alloy undergoes a one-time change in resistance; refer to burning-in effect.
- 4. Allow all part (e.g. heat-sealing band, base, body) to completely cool off.
- 5. Perform AUTOCAL again when the heat-sealing band is cold.
 - ⇒ The temperature controller calibrates itself to the new cold resistance of the heat-sealing band.
 - ⇒ The heating element is burned in and the change in resistance stabilizes. The system is now ready for operation.

Note The burn-in effect described can be omitted if the heat-sealing band has already been thermally pretreated by the manufacturer. Take into consideration the later sealing temperature for the specific application.

7 Display and operating elements

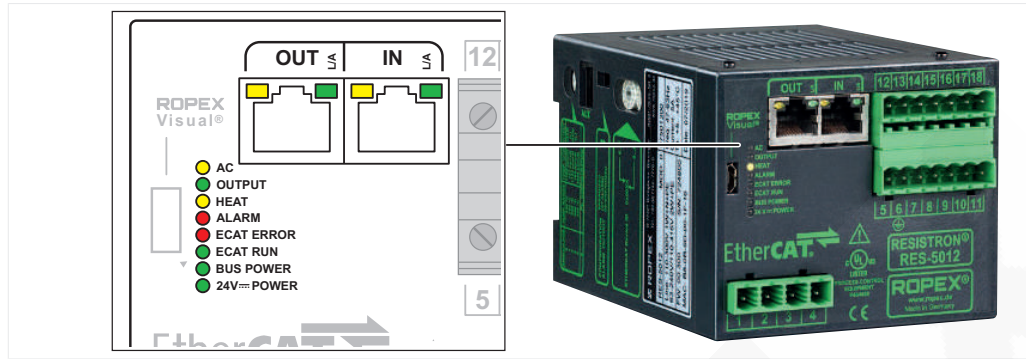

Illustration 9: Display of operating status

The LEDs indicate the operating status of the temperature controller.





Type of flashing

LED	Status	
	Remains on/off	
	Flashing	1 Hz (slowly)
		2 Hz
		4 Hz (quickly)
		8 Hz
	Flickers	8 Hz

Overview of LEDs

LED	Flashes slowly (1 Hz)	Flashes quickly (4 Hz)	Remains on
L/A IN, OUT	—	The device sends/receives EtherCAT® telegrams.	Connection to EtherCAT® network exists.
AC (AUTO CAL)	RS bit set (reset) or waiting for line voltage; refer to section Standby active (SA).	AUTO CAL requested but feature is blocked (e.g. START is active); refer to section Automatic zero calibration AUTO CAL (AC) [► 39].	AUTO CAL is performed.
		LED flashes at different frequency: 24 VDC supply is too low.	
		LED flickers approx. 2 seconds: Boot loader ⁸⁾ starts.	
OUTPUT	—	In control mode, the brightness is proportional to the heating current. In measuring mode or during the cooling phase of the heat-sealing band, the LED indicates the measuring pulses by flashing briefly.	

⁸⁾ Available beginning with firmware version 314

LED	Flashes slowly (1 Hz)		Flashes quickly (4 Hz)		Remains on
HEAT	—		START requested but feature is blocked (e.g. AUTOCAL is active, set-point < 40 °C); refer to section Start (ST) [▶ 41].		START is performed. 
ALARM	Configuration error, AUTOCAL was not successful; refer to section Error messages [▶ 69].		Temperature controller calibrated incorrectly; perform AUTOCAL.		For error diagnosis, refer to Error messages [▶ 69]. 
ECAT ERROR	Flashes once: local error Flashes twice: Process data watchdog Flashes at 2.5 Hz: invalid configuration. Master cannot perform status change				—
ECAT RUN	Flashes once: Safe operational Flashes at 2.5 Hz: Pre-operational				Operational 
BUS POWER	—		—		Internal supply voltage is OK. 
24 V POWER	—		—		The external 24 VDC supply voltage is being applied. 

8 Functions and settings

8.1 Communication via interface

Note Further information on the EtherCAT® interface can be found in the description of the PLC.

The temperature controller can communicate via the PROFINET interface, provided the 24 VDC supply voltage (terminals 5+7) is present.

8.2 Device master file (ESI)

Project tools for the EtherCAT® master interpret the content of the device master files and use this information to create a parameter set for the EtherCAT®. The master controls the user data traffic.

The device master file *ROPEX RES-5012 UPT-6012 Vx.xml* contains all essential temperature controller information for the projection, e.g.

- I/O data description
- Parameter descriptions
- Error messages

The Device description file can be requested

An IP address can be configured manually in the project tool. The IP address is assigned to the temperature controller when the connection is established.

If the temperature controller has an IP address, the device master file can also be downloaded from the integrated web server; refer to the section [Webserver \[57\]](#).

Once the device master file has been integrated into the project tool, set the desired parameter values. Refer to section [Object index \[44\]](#) for further information.

8.3 Communication protocol

The communication protocol consists of 2x16 bit input words and 4x16 bit output words (from the point of view of the temperature controller).

Bits 0...7 form the low byte and bits 8...15 the high byte ("INTEL format").

The 2x16-bit **input data** contains the setpoint in word 1 and the control functions in word 2 as follows:

1	Spare							Setpoint / AC temperature / regulation ratio								
Name	0	0	0	0	0	0	0									
Bit no.	15	14	13	12	11	10	9	8	7	6	5	4	3	2	1	0

2	Spare					Channel			Spare		Control function					
Name	0	0	0	0	0	CH2	CH1	CH0	0	0	KS ⁹⁾	MA	MP	RS	ST	AC
Bit no.	15	14	13	12	11	10	9	8	7	6	5	4	3	2	1	0

The 4x16 bit **output data** contains the actual value in word 1, the status information in word 2, the error code in word 3 and the start temperature in word 4 as follows:

1	Actual value (signed)															
Name																
Bit no.	15	14	13	12	11	10	9	8	7	6	5	4	3	2	1	0

2	Spare				Channel			Status information								
Name	0	0	0	MU ¹⁰⁾	CH2	CH1	CH0	SA	IA	WA	AA	AG	AL	TE	TO	RA
Bit no.	15	14	13	12	11	10	9	8	7	6	5	4	3	2	1	0

3	Error code																
Name	0	0	0	0	0	0	0	A9	A8	A7	A6	A5	A4	A3	A2	A1	A0
Bit no.	15	14	13	12	11	10	9	8	7	6	5	4	3	2	1	0	

4	Start temperature (signed)															
Name																
Bit no.	15	14	13	12	11	10	9	8	7	6	5	4	3	2	1	0

8.4 Input data

The input data is transmitted from the EtherCAT[®] Master to the temperature controller. The input data contains the setpoint as well as the control functions such as START or AUTOCAL for the temperature controller

The input data is shown as control bits.

8.4.1 Automatic zero calibration AUTOCAL (AC)

Perform zero calibration (AUTOCAL) in the following cases:

- After the heat-sealing band has been changed.
- After burning in.

⁹ Beginning with firmware version 305

¹⁰ Beginning with firmware version 303

- When secondary lines have been replaced and terminals tightened.
- When the system has been changed, e.g. changing secondary voltage.
- When the temperature coefficient has been changed.

Note If the ambient temperature changes, automatic zero calibration (AUTOCAL) is not necessary.

Calibration temperature Automatic zero calibration AUTOCAL (AC) means that manual zero calibration on the temperature controller is not necessary. This function adjusts the temperature controller to the current and voltage signals present in the system. The temperature controller adjusts itself to the value predefined in the parameter data; refer to section Calibration temperature [► 51]. If no parameter data is transferred by the EtherCAT® Master, the default value is 20 °C.

When the EtherCAT® Master supports Acyclical services, the calibration temperature can be sent directly to the temperature controller while the PLC program is running.

Alternative The calibration temperature can thus be specified by means of the "Setpoint / AC temperature / regulation ratio" whenever the zero point is calibrated, provided this is permitted in the parameter data (Refer to section Calibration temperature [► 51]). It can be specified within the range of 0...+40 °C.

In the parameter data, the parameter "Calibration data" has to be set to "0xFF" instead of "-1".

The specified calibration temperature must be entered in the "Setpoint / AC temperature / regulation ratio" input data when the AUTOCAL function is activated (AC bit = 1). This specified value must not be changed until the AUTOCAL function has finished.



NOTICE

Property damage if the heat-sealing band overheats.

When the function AUTOCAL is performed while the heat-sealing band is warm, zero calibration will be faulty, leading to poor sealing results.

- Wait until the heat-sealing band and tools have cooled off.

Calibration If the specified temperature is too high (greater than 40 °C) or if the specified value fluctuates, an error message appears:

- error codes 115 and 116; refer to section Error messages [► 69].

The AUTOCAL request (AC bit = 1) is executed by the temperature controller, provided the AUTOCAL function is not blocked; refer to AUTOCAL blocked (AG).

The automatic calibration takes approx. 10...15 seconds. The heat-sealing band is not heated additionally during this process. The yellow LED on the front panel lights up while the AUTOCAL function is executing and the temperature controller shows "AUTOCAL active" (AA bit = 1) in the output data. The actual value output (terminals 17+18) changes to 0...3 °C (corresponds to approx. 0 VDC).

If the temperature of the heat-sealing band fluctuates, the AUTOCAL function is executed a maximum of three times. If the function still cannot be executed successfully, an error message appears; refer to section Error messages [► 69].

AUTOCAL blocked **The AUTOCAL function is blocked:**

- During the first 10 seconds after both voltage supplies are switched on, if no alarm is reported.
- During the first 10 seconds after resetting the temperature controller, if no alarm is reported.
- If the cooling rate of the heat-sealing band is greater than 0.1 K/s.

Note:

If the AC bit is activated and the cooling rate has fallen below 0.1 K/s, the temperature controller carries out the AUTOCAL function.

- If the *Start* bit is activated (ST bit = 1).
The HEAT LED is illuminated or flashing.

- If the `Reset` bit is activated (RS bit = 1).
The AUTOCAL LED flashes slowly (1 Hz).
- If error codes 101 to 103, 201 to 203 or 9xx occur directly after switching on the temperature controller; refer to section Error messages [▶ 69].
- if the temperature controller has operated correctly at least once after being switched on and error codes 201 to 203 or 9xx occur; refer to section Error messages [▶ 69].
- If the line voltage is missing.
The AUTOCAL LED flashes slowly (1 Hz).

- Notes**
- If the AUTOCAL function is blocked, the temperature controller reports `Autocal blocked` in the output data (AG bit = 1). If there is an AUTOCAL request in the input data at the same time (AC bit = 1), the AUTOCAL LED flashes quickly (4 Hz).
 - The AC bit can be reset as soon as the temperature controller has activated the bit AA in its status information.
 - If the AC bit remains set beyond the end of the AUTOCAL function, the AUTOCAL LED flashes at a rate of 4 Hz. A flashing LED indicates that the request is still current but cannot be performed. The AA bit remains active until AC has been reset. This makes it easy to implement a "handshake" process.

8.4.2 Start (ST)

When the `Start` bit is set (ST bit = 1), the device's internal set/actual comparison is enabled.

The heat-sealing band is heated to the setpoint temperature. It remains at this temperature either until the ST bit is reset or until the actual heating time exceeds the preset heating time limit.

The LED HEAT remains illuminated during the heating time.

Information on the heating time limit can be found in section Heating time limit [▶ 52].

A start request is **not** processed as long as:

- The AUTOCAL function is active.
- The temperature controller indicates a fault.
- The setpoint is lower than 40 °C.
- The RS bit is set.

The heatup process is terminated:

- By resetting the ST bit.
- If a communication error occurs.
- If an error occurs.
- If the RS bit is activated.
- If the heating time limit is not at 0 and the set time has elapsed.

The alarm relay is switched if the ST bit is set while a warning with error code 104... 106, 111...114, 211, 302, or 303 is indicated. The heating element is not heated.

Information on the warnings with the respective error codes can be found in section Error messages [▶ 69].

8.4.3 Reset (RS)

The bit `Reset` resets the temperature controller if the temperature controller shows a fault.

No AUTOCAL or START requests are accepted as long as the RS bit is set. Until it is reset again, only error codes 201...203, 901, 913 are evaluated and output by the error diagnosis function. The power unit is not activated in this state. The temperature controller does not generate any measuring pulses. As a result, the actual value is no longer updated. The reset request is not accepted until the RS bit is reset.

Communication Resetting the temperature controller does not interrupt the EtherCAT® communication.

The actual value output changes to 0...3 °C (i.e. approximately 0 VDC) and the bit `Standby active` (SA bit) is set in order to set the RS bit.

Execution of the AUTOCAL function is not disrupted by activation of the RS bit.

After the RS bit is reset, the temperature controller performs internal initialization for approx. 500 ms. The next sealing process cannot be started until this is completed.

If a Kb contactor is used to deactivate the control loop, it must be reliably energized again 200 ms at the latest after the RS bit is reset.

Note the contactor switching and delay times. If it is energized too late, an error message appears on the temperature controller.

Information on the contactor Kb to shut off the control loop can be found in section Power supply [► 24].

The restart delay is adjustable to the contactor beginning with the firmware version 305. Information can be found in section Restart delay after reset [► 56].

8.4.4 Measurement pause (MP)

No more measuring pulses are generated by the temperature controller once the `Measurement pause` (MP bit) is set.

Only error codes 201...203, 901, 913 are evaluated and output by the error diagnosis function. In addition, the actual value is no longer updated. The last valid value before the MP bit was set is output. As soon as the MP bit is deleted, new measuring pulses are generated, all diagnoses are activated, and the actual value is updated again.

The MP bit is only active in measurement mode. The bits ST, RS, and AC take priority.

Example The bit is suitable for all applications in which the electrical connections of the heat-sealing band must be disconnected during normal operation without triggering a fault (e.g. sliding rail contacts).

Unlike the RS bit (RESET), the MP bit does not delete any error messages when it is set. The temperature controller is active again as soon as the MP bit is reset; in other words there is no initialization phase.

When the temperature controller is switched on, it does not evaluate the MP bit until the system test (including the functional test of the heat-sealing band) has been successfully completed. This can take several hundred milliseconds.

8.4.5 Master AUTOCAL (MA)

Setting the bit `Master AUTOCAL` (MA bit) starts calibration.

The MA bit can be used as an alternative to the AC bit (automatic zero calibration AUTOCAL) to start calibration.

Master AUTOCAL saves the resistance as an additional reference value. It is not overwritten during automatic zero calibration (AUTOCAL). Master AUTOCAL and AUTOCAL behave the same in all other ways. The LED indicators also apply to both AUTOCAL and master AUTOCAL.

Example The function master AUTOCAL can be performed after replacing the heat-sealing band. The heat-sealing band resistance is saved as a reference value here. This reference value serves to calculate the deviation from the calibration value for all subsequent calibrations (initiated with the AC bit).

Query deviation from calibration value is done via the object 0x4306.

8.4.6 Constant regulation ratio (KS)



DANGER

Fire hazard due to uncontrolled heatup

Using alloys with temperature coefficients that are too low or incorrect coding of the temperature controller cause uncontrolled heatup. The heat-sealing band can burn up.

- ▶ Use a heat-sealing band with the proper temperature coefficient.
- ▶ Set the correct temperature coefficient in the temperature controller.
- ▶ Set the correct temperature range in the temperature controller.



NOTICE

Property damage if the heat-sealing band overheats.

High regulation ratios cause the heat-sealing band to heat up quickly. The heat-sealing band can burn up.

- ▶ Operate the machine under real conditions.
- ▶ Determine the regulation ratio by trial and error.
- ▶ When determining the value, start at 10 % and increase the value in small steps.

Available beginning with firmware version

This function is available with firmware version 305 and higher.

The constant regulation ratio bit (KS) has a control function. By activating the bit, a constant power regulation ratio will be output. If the KS bit is activated, there is no temperature control.

The setpoint for the constant regulation ratio is entered in the element "Setpoint / AC temperature / regulation ratio"; refer to section Setpoint [▶ 44].

The power regulation ratio is stated as a percentage of the maximum power. The permitted range of values is 0...100 %.

- Notes**
- For values greater than 100%, the temperature controller limits the power to 100%.
 - For values from 0% to 3%, the temperature controller generates power of 3%. The temperature controller is not in control mode, but the heat-sealing band can heat up.

8.4.7 Channel selection (CH0...CH2)

The temperature controller has separate memories for up to eight calibration data records. A calibration data record contains the values determined by the temperature controller during the AUTOCAL function.

Storing the calibration data records allows the operator to alternate between different sealing tools without having to run the AUTOCAL function every time the tool is changed. AUTOCAL needs to be executed only when a new heat-sealing band is connected.

Since different calibration values, AUTOCAL temperatures and temperature coefficients are stored in the temperature controller for this purpose, the required calibration data record 0...7 can be selected with the three bits CH0...CH2.

Example This function is useful, for instance, in applications where frequent changes of format are necessary.

The tools can then be changed as required in order to handle the different formats.

A channel containing the relevant calibration data record is assigned to each tool. Once all tools have been calibrated with a unique channel assignment, they can be changed at any time simply by selecting the appropriate channel.

Tip If the application does not require any format changes, the channel can remain set to 0. In this case, the temperature controller behaves in exactly the same way as older models, where different calibration data records are not supported.

It is possible to switch to another channel during the AUTOCAL function; however, the temperature controller continues working with the original channel until the AUTOCAL function has finished. The channel currently being used by the temperature controller is shown in the status information; refer to 4 x 16 bit **output data**, byte 2, bit number 9-11 (channel CH0, CH1 and CH2), section Communication protocol [► 39].

8.4.8 Setpoint

The setpoint is scaled in steps of 1 °C.

In the first input word, the setpoint is at bits 8...0. Bit 0 is counted as well. This allows values up to 511 to be shown.

Minimum setpoint The minimum setpoint is 40 °C.

Maximum setpoint The maximum setpoint is limited as factor of the set temperature range.

Information on the temperature range can be found in section Temperature range and alloy [► 50].

The maximum setpoint can also be limited in the object index; refer to section Object index [► 44].

It is also possible to set the maximum setpoint via the visualization software. Further information can be found in the operating instructions for the visualization software *ROPEXvisual*[®].

If the calibration temperature is set to -1 in the parameter data, the setpoint determines the AUTOCAL temperature when automatic zero calibration is activated. Refer to section Automatic zero calibration AUTOCAL (AC) [► 39] for further information.

When constant regulation mode (KS bit = 1) is activated, the setpoint determines the constant regulation ratio.

Refer to section Constant regulation ratio (KS) [► 43] for further information.

8.5 Object index

Note Decimal values are transferred as whole numbers and have to be converted.

Example The heating time limit is within the range 0...99.9 s. But the temperature controller values are within the range of 0...999.

Programming PLC:

Divide the values by 10 when reading. Multiply them by 10 when writing.

Index: Subindex	Name	Access	Default ⁽¹⁾	Value range	Data type
1000	Device type	RO	0		UINT32
1001	Error register	RO	0	0...255	UINT8
1008	Manufacturer device name	RO	RES-5012		
100A	Manufacturer software version	RO	303		UINT32
1018:00	Identity object	RO	4		UINT8
1018:01	Vendor ID	RO	0x00000576		UINT32
1018:02	Product code	RO	0xE3		UINT32
1018:03	Revision number	RO	0x00010001		UINT32
1018:04	Serial number	RO			UINT32

¹¹ The default is saved in the EDI file.

Index: Subindex	Name	Access	Default ¹¹⁾	Value range	Data type
10F300	Diagnosis history	RO	5		UINT8
10F3:01	Maximum messages	RW	250	1...250	UINT8
10F3:02	Newest message	RO	0	0, 6...255	UINT8
10F3:03	Newest acknowledged message	RW	0	0, 6...255	UINT8
10F3:04	New messages available	RO	0	0 (false), 1 (true)	BOOL
10F3:05	Flags	RW	0		UINT32
10F8	Time stamp object	RO	0		UINT32
1600:00	RxPDO	RO	10 ¹²⁾		UINT8
1600:01	SubIndex 001	RO	0x20000110		UINT32
1600:02	SubIndex 002	RO	0x20000201		UINT32
1600:03	SubIndex 003	RO	0x20000301		UINT32
1600:04	SubIndex 004	RO	0x20000401		UINT32
1600:05	SubIndex 005	RO	0x20000501		UINT32
1600:06	SubIndex 006	RO	0x20000601		UINT32
1600:07	SubIndex 007	RO	0x20000701		UINT32
1600:08	SubIndex 008	RO	0x20000802		UINT32
1600:09	SubIndex 009	RO	0x20000903		UINT32
1600:0A	SubIndex 010	RO	0x20000A05		UINT32
1A00:00	TxPDO	RO	15		UINT8
1A00:01	SubIndex 001	RO	0x30000110		UINT32
1A00:02	SubIndex 002	RO	0x30000201		UINT32
1A00:03	SubIndex 003	RO	0x30000301		UINT32
1A00:04	SubIndex 004	RO	0x30000401		UINT32
1A00:05	SubIndex 005	RO	0x30000501		UINT32
1A00:06	SubIndex 006	RO	0x30000601		UINT32
1A00:07	SubIndex 007	RO	0x30000701		UINT32
1A00:08	SubIndex 008	RO	0x30000801		UINT32
1A00:09	SubIndex 009	RO	0x30000901		UINT32
1A00:	SubIndex 010	RO	0x30000A01		UINT32
1A00:0B	SubIndex 011	RO	0x30000B03		UINT32
1A00:0C	SubIndex 012	RO	0x30000C01		UINT32
1A00:0D	SubIndex 013	RO	0x30000D03		UINT32
1A00:0E	SubIndex 014	RO	0x30000E10		UINT32
1A00:0F	SubIndex 015	RO	0x30000F10		UINT32
1C00:00	Sync manager communication type	RO	8		UINT8
1C00:01	SubIndex 001	RO	1		UINT8
1C00:02	SubIndex 002	RO	2		UINT8

¹² Available beginning with firmware version 305

Index: Subindex	Name	Access	Default ¹¹⁾	Value range	Data type
1C00:03	SubIndex 003	RO	3		UINT8
1C00:04	SubIndex 004	RO	4		UINT8
1C00:05	SubIndex 005	RO	0		UINT8
1C00:06	SubIndex 006	RO	0		UINT8
1C00:07	SubIndex 007	RO	0		UINT8
1C00:08	SubIndex 008	RO	0		UINT8
1C12:00	SyncManager 2 PDO assignment	RO	1		UINT8
1C12:01	SubIndex 001	RO	0x1600		UINT16
1C13:00	SyncManager 3 PDO assignment	RO	1		UINT8
1C13:01	SubIndex 001	RO	0x1A00		UINT16
2000:00	Outputs	RO	10 ¹²⁾		UINT8
2000:01	Setpoint	RW	0	0...500	UINT16
2000:02	AC (AUTOCAL)	RW	0	0 (off), 1 (on)	BOOL
2000:03	ST (Start)	RW	0	0 (off), 1 (on)	BOOL
2000:04	RS (Reset)	RW	0	0 (off), 1 (on)	BOOL
2000:05	MP (Measurement pause)	RW	0	0 (off), 1 (on)	BOOL
2000:06	MA (Master AUTOCAL)	RW	0	0 (off), 1 (on)	BOOL
2000:07	KS (constant reg. ratio) ¹²⁾	RW	0	0	BOOL
2000:08	Reserved_1	RW	0	0	BIT2
2000:09	Channel	RW	0	0...7	BIT3
2000:0A	Reserved_2	RW	0	0	BIT5
3000:00	Inputs	RO	15		UINT8
3000:01	Actual temperature	RO	0	-99...999	INT16
3000:02	RA (Control active)	RO	0	0 (off), 1 (on)	BOOL
3000:03	TO (Temperature OK)	RO	0	0 (off), 1 (on)	BOOL
3000:04	TE (Temperature Achieved)	RO	0	0 (off), 1 (on)	BOOL
3000:05	AL (Alarm Active)	RO	0	0 (off), 1 (on)	BOOL
3000:06	AG (AUTOCAL blocked)	RO	0	0 (off), 1 (on)	BOOL
3000:07	AA (AUTOCAL active)	RO	0	0 (off), 1 (on)	BOOL
3000:08	WA (Warning Active)	RO	0	0 (off), 1 (on)	BOOL
3000:09	IA (Information Active)	RO	0	0 (off), 1 (on)	BOOL
3000:0A	SA (Standby Active)	RO	0	0 (off), 1 (on)	BOOL
3000:0B	Channel	RO	0	0...7	BIT3
3000:0C	MU (Measurement interruption)	RO	0	0 (off), 1 (on)	BOOL
3000:0D	Reserved	RO	0	0	BIT3
3000:0E	Alarm code	RO	0	0...999	UINT16
3000:0F	Start temperature	RO	-99	-99...999	INT16

Index: Subindex	Name	Access	Default ⁽¹⁾	Value range	Data type
4000	Alloy / temperature range	RW	10	0, 1, 4, 5, 8, 9, 10, 11 (7.11.1 [▶ 50])	
4001	Low temperature threshold	RW	10 K	3...99 K	UINT8
4002	High temperature threshold	RW	10 K	3...99 K	UINT8
4003:00	Calibration temperature, -1 -> variable	RO	8		UINT8
4003:01	SubIndex 001	RW	20 °C	-1, 0...40 °C	INT8
4003:02	SubIndex 002	RW	20 °C	-1, 0...40 °C	INT8
4003:03	SubIndex 003	RW	20 °C	-1, 0...40 °C	INT8
4003:04	SubIndex 004	RW	20 °C	-1, 0...40 °C	INT8
4003:05	SubIndex 005	RW	20 °C	-1, 0...40 °C	INT8
4003:06	SubIndex 006	RW	20 °C	-1, 0...40 °C	INT8
4003:07	SubIndex 007	RW	20 °C	-1, 0...40 °C	INT8
4003:08	SubIndex 008	RW	20 °C	-1, 0...40 °C	INT8
4004	Heating time limit (in 100 ms)	RW	0	0...999 (0...99.9 s)	UINT16
4005	Diagnosis	RW	On	0 (off), 1 (on)	UINT8
4006	Measuring pulse duration	RW	17	17...30 (1.7...3.0 ms)	UINT8
4007	Data format	RW	0	0 (Little Endian Intel), 1 (Big Endian Motorola)	UINT8
400A:00	Temperature coefficient	RO	8		UINT8
400A:01	SubIndex 001	RW	1100 ppm/K	400...4000 ppm/K	UINT16
400A:02	SubIndex 002	RW	1100 ppm/K	400...4000 ppm/K	UINT16
400A:03	SubIndex 003	RW	1100 ppm/K	400...4000 ppm/K	UINT16
400A:04	SubIndex 004	RW	1100 ppm/K	400...4000 ppm/K	UINT16
400A:05	SubIndex 005	RW	1100 ppm/K	400...4000 ppm/K	UINT16
400A:06	SubIndex 006	RW	1100 ppm/K	400...4000 ppm/K	UINT16
400A:07	SubIndex 007	RW	1100 ppm/K	400...4000 ppm/K	UINT16
400A:08	SubIndex 008	RW	1100 ppm/K	400...4000 ppm/K	UINT16
400B	Temperature range	RW	1	0 (200 °C), 1 (300 °C), 2 (400 °C), 3 (500 °C)	UINT8
400C	Temperature max.	RW	300 °C	200...500 °C	UINT16
400D	Temperature diagnosis	RW	0	0 (off), 1 (on)	UINT8
400E	Temperature diagnosis delay (in 100 ms)	RW	0 s	0...99 (0...9.9 s)	UINT8

Index: Subindex	Name	Access	Default ¹¹⁾	Value range	Data type
400F	Heatup time (in 100 ms)	RW	0 s	0...999 (0...99.9 s)	UINT16
4010	AUTOCOMP	RW	0	0 (off), 1 (on), 2 (automatic)	UINT8
4011	Bit temperature OK (output 1)	RW	1	0 (off), 1 (active when Tact=Tset) 2 (active when Tact=Tset with latch)	UINT8
4012	Hold mode	RW	0	0 (off), 1 (on), 2 (2 seconds)	UINT8
4014	Restart delay after reset ¹²⁾ (in 10 ms)	RW	20 (0.20 s)	0...999 (0...9.99 s)	UINT16
4015	Maximum measurement pause [periods] ¹²⁾	RW	10	0...10	UINT8
4300	System date	RW			UINT32
4301	System time	RW			UINT32
4302	Operating hours	RO	0	0...999999999 (0... 99999999.9 h)	UINT32
4303	Cycle counter, total	RO	0	0...999999999	UINT32
4304	Cycle counter, total, clearable	RW	0	0...999999999	UINT32
4305:00	Cycle counter per channel, clearable	RO	8		UINT8
4305:01	SubIndex 001	RW	0	0...999999999	UINT32
4305:02	SubIndex 002	RW	0	0...999999999	UINT32
4305:03	SubIndex 003	RW	0	0...999999999	UINT32
4305:04	SubIndex 004	RW	0	0...999999999	UINT32
4305:05	SubIndex 005	RW	0	0...999999999	UINT32
4305:06	SubIndex 006	RW	0	0...999999999	UINT32
4305:07	SubIndex 007	RW	0	0...999999999	UINT32
4305:08	SubIndex 008	RW	0	0...999999999	UINT32
4306:00	Calibration deviation	RO	8		UINT8
4306:01	SubIndex 001	RO	0	-10000...10000 (-100.00... 100.00 %)	INT16
4306:02	SubIndex 002	RO	0	-10000...10000 (-100.00... 100.00 %)	INT16
4306:03	SubIndex 003	RO	0	-10000...10000 (-100.00... 100.00 %)	INT16

Index: Subindex	Name	Access	Default ⁽¹⁾	Value range	Data type
4306:04	SubIndex 004	RO	0	-10000...10000 (-100.00... 100.00 %)	INT16
4306:05	SubIndex 005	RO	0	-10000...10000 (-100.00... 100.00 %)	INT16
4306:06	SubIndex 006	RO	0	-10000...10000 (-100.00... 100.00 %)	INT16
4306:07	SubIndex 007	RO	0	-10000...10000 (-100.00... 100.00 %)	INT16
4306:08	SubIndex 008	RO	0	-10000...10000 (-100.00... 100.00 %)	INT16
4307	Passes through current transformer	RW	1	1...9	UINT8
4308:00	Calibration resistance	RO	8		UINT8
4308:01	SubIndex 001	RO	0	0...65535 (0...6553.5 mΩ)	UINT16
4308:02	SubIndex 002	RO	0	0...65535 (0...6553.5 mΩ)	UINT16
4308:03	SubIndex 003	RO	0	0...65535 (0...6553.5 mΩ)	UINT16
4308:04	SubIndex 004	RO	0	0...65535 (0...6553.5 mΩ)	UINT16
4308:05	SubIndex 005	RO	0	0...65535 (0...6553.5 mΩ)	UINT16
4308:06	SubIndex 006	RO	0	0...65535 (0...6553.5 mΩ)	UINT16
4308:07	SubIndex 007	RO	0	0...65535 (0...6553.5 mΩ)	UINT16
4308:08	SubIndex 008	RO	0	0...65535 (0...6553.5 mΩ)	UINT16
4309:00	Initial calibration resistance	RO	8		UINT8
4309:01	SubIndex 001	RO	0	0...65535 (0...6553.5 mΩ)	UINT16
4309:02	SubIndex 002	RO	0	0...65535 (0...6553.5 mΩ)	UINT16
4309:03	SubIndex 003	RO	0	0...65535 (0...6553.5 mΩ)	UINT16
4309:04	SubIndex 005	RO	0	0...65535 (0...6553.5 mΩ)	UINT16
4309:05	SubIndex 005	RO	0	0...65535 (0...6553.5 mΩ)	UINT16
4309:06	SubIndex 006	RO	0	0...65535 (0...6553.5 mΩ)	UINT16

Index: Subindex	Name	Access	Default ¹¹⁾	Value range	Data type
4309:07	SubIndex 007	RO	0	0...65535 (0...6553.5 mΩ)	UINT16
4309:08	SubIndex 008	RO	0	0...65535 (0...6553.5 mΩ)	UINT16
430A:00	TCR calculator ¹³⁾ (8.11.2)	RO	2		UINT8
430A:01	External measured temperature	RW	40	40...600 °C	UINT16
430A:02	Calculated temperature coefficient	RO	0	400...4000 ppm/K 0 (error), 65535 (error)	UINT16

8.5.1 Temperature range and alloy

This parameter can be used to select both the temperature range and the heat-sealing band alloy. The setting of the coding dial can be overwritten by changing the default value (10).

Information on setting the coding dial can be found in section Setting coding dial for temperature range and alloy

Object index When the values for the temperature ranges and the alloy are configured in the Index: Subindex 4000, the position of the coding dial is ignored.

Index: Subindex 4000 Value	Coding dial position	Temperature range	Temperature coefficient TCR	Example of heat-sealing band alloy	
0	Not relevant	300 °C	1100 ppm/K	Alloy 20	
1		300 °C	780 ppm/K	Alloy L	
4		500 °C	1100 ppm/K	Alloy 20	
5		500 °C	780 ppm/K	Alloy L	
8		300 °C	3500 ppm/K	LEX3500	
9		► Set the configuration variables in the visualization software			
11		Object 0x400B	Object 0x400A		

Coding dial After configuring the temperature range and alloy via the coding dial, the value "10" (default) has to be entered in the Index: Subindex 4000.

Index: Subindex 4000 Value	Coding dial position	Temperature range	Temperature coefficient TCR	Example of heat-sealing band alloy
10¹⁴⁾	0¹⁴⁾	300 °C	1100 ppm/K	Alloy 20
	1	300 °C	780 ppm/K	Alloy L
	4	500 °C	1100 ppm/K	Alloy 20
	5	500 °C	780 ppm/K	Alloy L
	8	300 °C	3500 ppm/K	LEX3500

¹³ Available beginning with firmware version 309

¹⁴ Default

Index: Subindex 4000 Value	Coding dial position	Temperature range	Temperature coefficient TCR	Example of heat-sealing band alloy
10 ¹⁴⁾	9	▶ Set the configuration variables in the visualization software		

Always execute the AUTOCAL function after changing the temperature range, the temperature coefficient or the alloy parameter.

8.5.2 TCR calculator

Available beginning with firmware version

This function is available with firmware version 309 and higher.

The TCR calculator can be used to determine the temperature coefficient (TCR) of the heat-sealing band used.

Application

The real temperature coefficient of the heat-sealing band often differs from the standard value. The material composition and processing influence the properties of the heat-sealing band. This causes the temperature display of the temperature controller to differ from the real temperature of the heat-sealing band. Using the TCR calculator allows the TCR value to be easily corrected and the temperature display of the temperature controller and the real temperature of the heat-sealing band to be better matched.

Calculation

To calculate the TCR value, the temperature at the heat-sealing band is measured in control mode (ST bit = 1) using an external temperature sensor (e.g. a thermocouple). The measured temperature is transferred to the temperature controller in Object 0x430A:01. The calculated temperature coefficient can be read out from Object 0x430A:02. The temperature coefficient is only calculated in control mode (ST bit = 1). Reading back the calculated TCR value must be done during active control operation, i.e. during an active heating pulse, as the internal measured value of the current heat-sealing band temperature is used for the calculation.

Errors in the calculation of the temperature coefficient are reported with the value 0 (calculated temperature coefficient too low or no active control operation) or 65535 (calculated temperature coefficient too high).

To use the calculated TCR value, it must be set for the corresponding channel as the temperature coefficient in Object 0x400A (temperature coefficient). In addition, the value 11 (variable) must be used in Object 0x4000 (alloy / temperature range).

Further information can be found in the operating instructions for the TCR calculator.

8.5.3 Low temperature OK threshold

The low threshold value for temperature OK is the low threshold value for the "OK window."

Further information can be found in the sections Temperature OK (TO) and Temperature diagnosis [▶ 54].

8.5.4 High temperature OK threshold

The high threshold value for temperature OK is the high threshold value for the "OK window."

Further information can be found in the sections Temperature OK (TO) and Temperature diagnosis [▶ 54].

8.5.5 Calibration temperature

The calibration temperature is set to 20 °C by default. It can be changed to another value between 0 °C and 40 °C in order to adapt it to the temperature of the cold heat-sealing band.

The calibration temperature can be

- Specified with the aid of the hardware configuration tool, e.g. TwinCAT by Beckhoff.
- Changed during operation via the acyclical services, if the EtherCAT® Master supports acyclical services.
- Changed via the cyclical input data; refer to Setpoint [▶ 44]), if the value "1" for the calibration temperature is shown in the parameter data.

After changing the calibration temperature, execute the AUTOCAL function; refer to section Automatic zero calibration AUTOCAL (AC) [▶ 39].

8.5.6 Heating time limit

The heating time limit provides additional protection against unwanted continuous heating.

The temperature controller automatically deactivates the heating pulse after the set heating time limit has elapsed, if the ST bit remains set for longer than the time specified with this limit. The ST bit must be reset before the temperature controller can be started up again.

The heating time limit is deactivated by default (0) but can be set to any value between 0.1 s and 99.9 s (1 and 999).

8.5.7 Measuring pulse duration

The length of the measuring pulses generated by the temperature controller can be set with this parameter.

It may be necessary to set a measuring pulse longer than the default 1.7 ms for certain applications. Refer to the application report for more detailed information, or consult support: 8.5.8 Data format

This parameter specifies the order of the bytes ("Little Endian (Intel)" or "Big Endian (Motorola)") in the cyclical data. This setting applies to both input and output data. Refer to section Communication protocol [▶ 39].

8.5.9 Automatic phase correction (AUTOCOMP)

It may be necessary to compensate the phase angle displacement between the U_R and I_R measuring signals for specific heat-sealing applications. The AUTOCOMP function may be needed for this purpose.

After changing the setting of the parameter AUTOCOMP, the behavior of the temperature controller remains unchanged until the function AUTOCAL is executed again. The compensation values are changed only after successful execution of the function AUTOCAL.

The function AUTOCOMP has to be enabled in the in the object index to be able to use it. Refer to section Object index [▶ 44] for further information.

Note The heat-sealing band becomes slightly warm when the function AUTOCOMP is executed. Heating is typically between 10 K and 30 K, depending on how the application is designed.

Default AUTOCOMP off

The following settings are possible:

Setting	Meaning	
Off	AUTOCOMP function switched off. (default)	

Setting	Meaning	
On	<p>The AUTOCOMP function is executed whenever the AUTOCAL function is executed twice in quick succession. Information on AUTOCAL can be found in section Automatic zero calibration AUTOCAL (AC) [▶ 39].</p> <p>The interval between the end of the first AUTOCAL function and the start of the second AUTOCAL must be shorter than 2.0 seconds. The second AUTOCAL function takes around 2.0 seconds and includes the AUTOCOMP function. If the interval between the two AUTOCAL functions is longer than 2.0 seconds, AUTOCAL is executed normally again the second time.</p> <p>The "OUTPUT" LED flashes several times when the AUTOCOMP function is executed and the actual value output (terminals 17+18) changes to 0...3 °C (corresponds to approx. 0 VDC).</p>	<p>The diagram shows four vertical axes representing different signals over time (t). 1. AC bit: Shows two pulses. The first pulse is at time t1. The second pulse is at time t2, with a double-headed arrow between the end of the first pulse and the start of the second pulse labeled '<2.0s'. 2. Function: Shows a long pulse labeled 'AUTOCAL' starting at t1 and ending at t2. A shorter pulse labeled 'AUTOCOMP' starts at t2. 3. "AUTOCAL" LED: Shows a long pulse labeled 'lights up' from t1 to t2, and a shorter pulse labeled 'lights up' starting at t2. 4. "OUTPUT" LED: Shows a series of regular pulses labeled 'lights up' from t1 to t2, followed by a series of very frequent pulses labeled 'lights up' starting at t2.</p>
AUTO	<p>The AUTOCOMP function is automatically activated after the AUTOCAL function has been successfully executed.</p> <p>The "OUTPUT" LED flashes several times when the AUTOCOMP function is executed and the actual value output (terminals 17+18) changes to 0...3 °C (corresponds to approx. 0 VDC).</p>	<p>The diagram shows four vertical axes representing different signals over time (t). 1. AC bit: Shows a single pulse at time t1. 2. Function: Shows a long pulse labeled 'AUTOCAL' starting at t1 and ending at t2. A shorter pulse labeled 'AUTOCOMP' starts at t2. 3. "AUTOCAL" LED: Shows a long pulse labeled 'lights up' from t1 to t2. 4. "OUTPUT" LED: Shows a series of regular pulses labeled 'lights up' from t1 to t2, followed by a series of very frequent pulses labeled 'lights up' starting at t2.</p>

8.5.10 Temperature diagnosis

An additional temperature diagnosis can be activated in the parameter data (ESI file). The temperature controller checks whether the actual temperature is within an adjustable tolerance range ("OK window") above and below the setpoint temperature.

Default The limits are set to -10 K and +10 K by default.

If the ACTUAL temperature is within the specified tolerance range when the START signal is activated, the temperature diagnosis is activated as well. If the ACTUAL temperature leaves the tolerance range, the corresponding error code (307, 308) appears and the alarm relay is switched; refer to section Error messages [► 69].

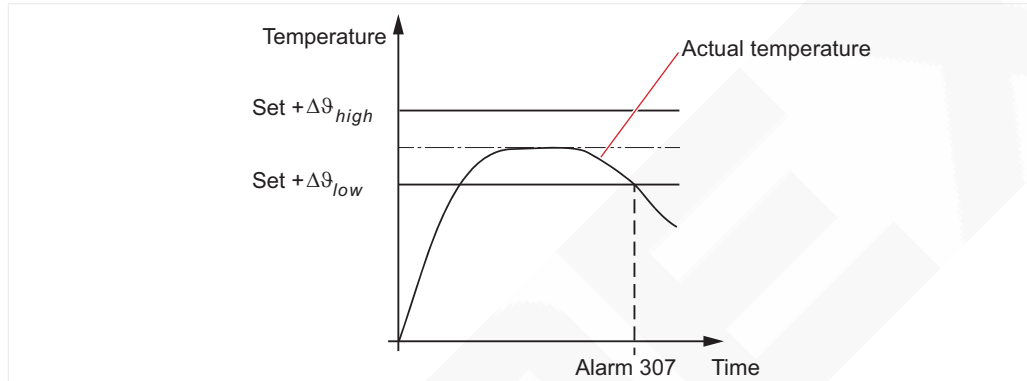

Illustration 10: Temperature diagnosis

The low ($\Delta\vartheta_{low}$) and high ($\Delta\vartheta_{high}$) tolerance limits are the same as for temperature OK monitoring. Information on setting the coding dial can be found in section. Temperature OK (TO)

If the actual temperature does not exceed the low tolerance limit or fall below the high tolerance limit, the corresponding error code (309, 310) appears and the alarm relay is switched. Temperature diagnosis was not switched on when the START signal was deactivated.

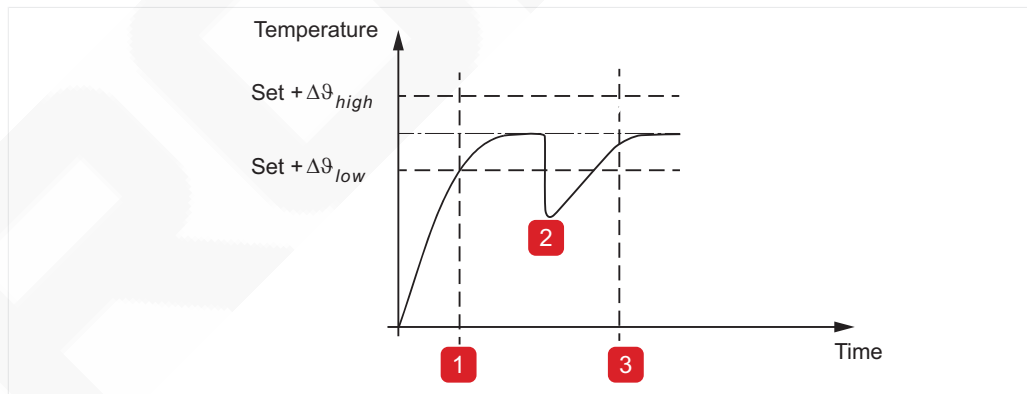

Illustration 11: Temperature diagnosis delay

1	Start of delay time for temperature diagnosis	2	Value falling below the low tolerance limit is ignored.
3	Temperature diagnosis delay has expired		

An additional delay (0...9.9 seconds can be set in their the object index (ESI file) .

The first time the value falls below the low tolerance limit **1**, temperature diagnosis is not activated until the configured delay time has elapsed.

The temperature diagnosis function can thus be selectively deactivated **2**, e.g. if the temperature drops temporarily owing to the closure of the sealing jaws.

Note The high and low tolerance limits cannot be set in the visualization software.

The low and high tolerance range limits are the same as with the TO bit. They can only be set in the object index.
Refer to section Object index [▶ 44] for further information.

8.5.11 Heatup timeout

Additional heatup timeout can be activated in the object index (ESI).

The time required to reach the setpoint temperature may be longer in the event of an electrical error, e.g. a broken cable or incorrect heating element. When heatup timeout is set to the value required for the respective application, errors of this type can be detected.

Default Heatup time out off

Heatup timeout is activated when the ST bit is activated. The temperature controller monitors the time that it takes for the actual temperature to reach 95 % of the setpoint temperature. If this time is longer than the configured time, the corresponding error code (304) appears and the alarm relay is switched; refer to section Error messages [▶ 69].

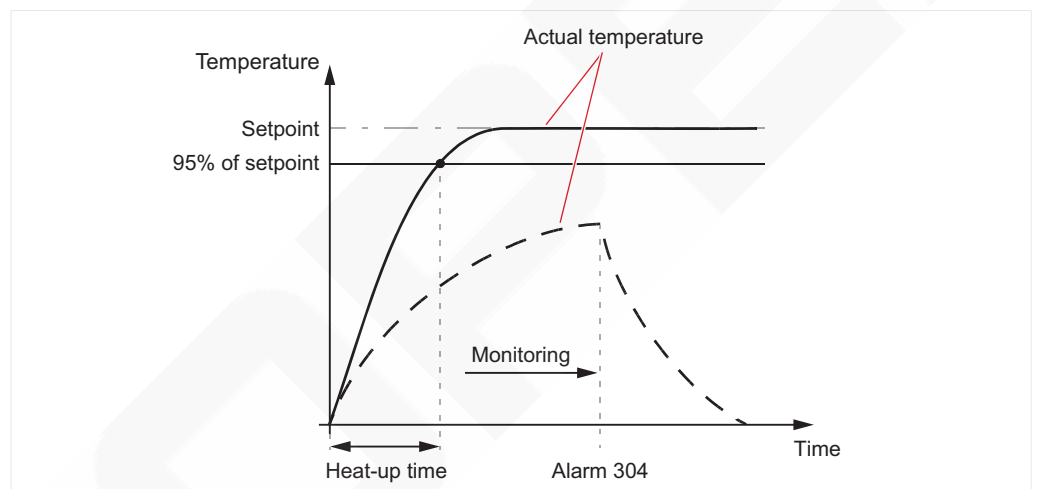

Illustration 12: Heatup timeout

To be able to use it, the "Heatup timeout" function has to be enabled in the object index.

Refer to section Object index [▶ 44] for further information.

8.5.12 Hold mode

The actual temperature output via the EtherCAT® protocol can be configured in the parameter data (ESI) as follows:

Setting	Meaning
Off	The current actual temperature is shown in realtime.
On	The current actual temperature is output at the end of the last heat-sealing phase. When the temperature controller is switched on, the current actual temperature is indicated up until the end of the first heating phase.
2 sec.	The last actual temperature is output for an additional 2 seconds at the end of a heat-sealing phase. Then the actual temperature is shown in realtime until the end of the next heat-sealing phase.

Default Hold mode off

Hold mode only applies to the actual temperature that is output via the EtherCAT® protocol and the digital temperature display in the ROPEX visualization software. It has no effect on the actual temperature that appears at the temperature controller's analog output or is plotted in the graphics window of the visualization software.

The various hold modes are shown below:

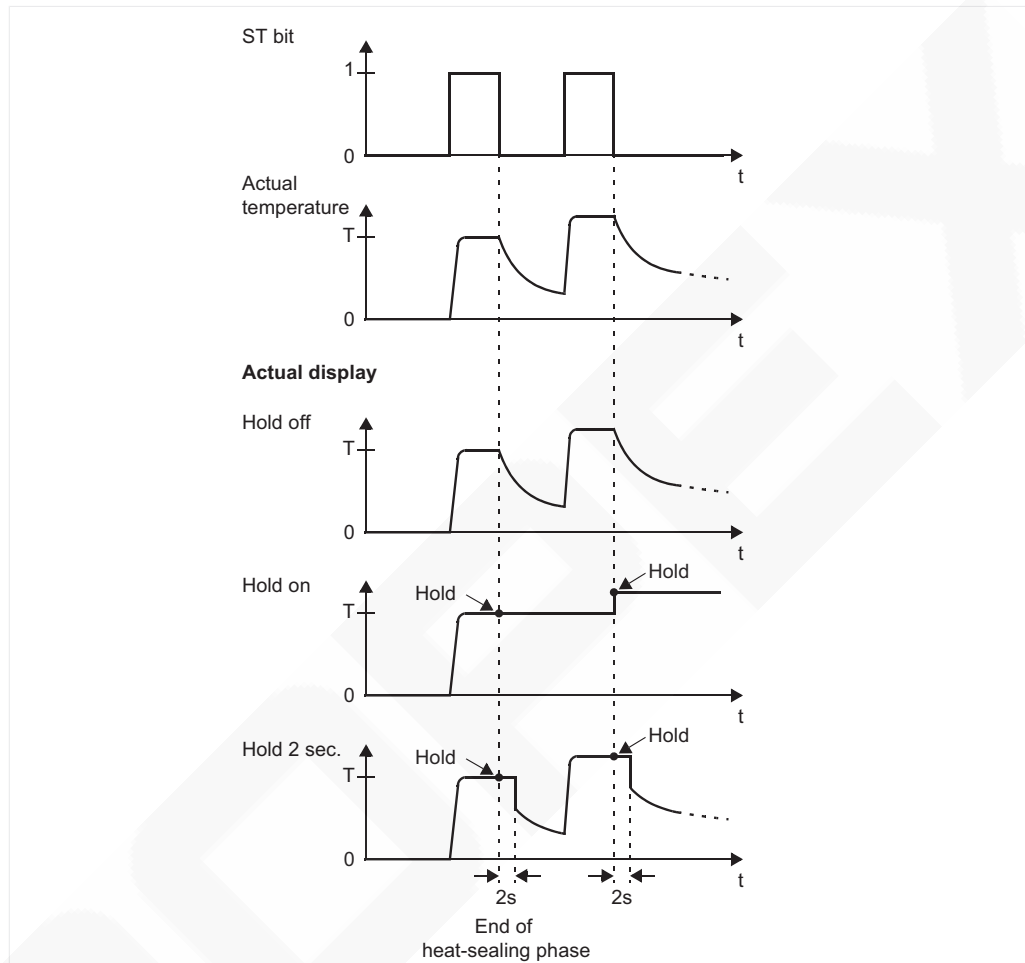

Illustration 13: Hold mode. Example: second pulse with greater setpoint

The settings for hold mode are made in the in the object index.

Refer to section Object index [► 44] for further information.

8.5.13 Restart delay after reset

Available beginning with firmware version

This function is available with firmware version 305 and higher.

After acknowledging an alarm with the reset signal (RS bit), the temperature controller waits until any contactor connected has closed the heat-sealing band again. When this time has elapsed, the temperature controller generates measuring pulses again in order to determine the actual temperature and to carry out error diagnostics.

This restart delay is 0.2 s by default and can be adjusted with Object 0x4014. This allows slower switching contactors to be used.

With firmware version 305

In older firmware versions, the restart delay is not included as a parameter. The restart delay is set to 0.2 s. This value cannot be changed.

8.5.14 Maximum measurement pause

Available beginning with firmware version

This function is available with firmware version 305 and higher.

If the temperature controller determines in control mode (ST bit = 1) that the current actual temperature is greater than the setpoint, the power supply to the heat-sealing band is reduced.

If the power reduction is not sufficient, the low-power measuring pulses, which determine the current actual temperature, are paused. This measurement pause can last up to 10 periods in the default setting. During this measurement pause, the temperature controller cannot react to a change in the actual temperature.

The status bit "measurement interruption active" is active at this time. Refer to section Measurement interruption (MU) for further information.

In certain applications it may be useful to shorten this maximum measurement pause, e.g. if the higher actual temperature values are caused by measurement errors. For this case the maximum measurement pause can be shortened with Object 0x4015

Note A measurement pause that is set too short can lead to an increased temperature if the system is incorrectly dimensioned (secondary voltage of the pulse transformer is too high) or if the sealing temperatures are low.

8.6 Webserver

Prerequisite The following prerequisite has to be met:

- The Ethernet connection is in place and the temperature controller has an IP address.

The integrated web server enables access to status information and parameter values of the temperature controller. The error protocol can be read out and displayed. A graph showing the last 5 seconds of a heating pulse allows evaluation of the controlled system.

The latest version of the operating instructions can be downloaded from the ROPEX website by clicking on the picture of the device.

The operating instructions cannot be opened without an internet connection.

Tip Click the ROPEX logo in the upper right corner of the screen to access the ROPEX website.

Note The webserver uses JavaScript and has been successfully tested with the following web browsers:

- Internet Explorer 9, 10, 11
- Mozilla Firefox
- Microsoft Edge
- Safari

8.6.1 Home

Home
Status
Parameters
Counters
Protocol
Graphic
Calibration

ROPEX

ROPEX RESISTRON® Temperature Controller

Welcome to the web interface of your ROPEX RESISTRON® Temperature Controller device RES-5012.

Here you can observe different operating parameters and status information. The device protocol can be uploaded and exported and the last heating impulses are shown in a graphical view.

The user manual for the device can be downloaded from [here](#) or by clicking on the device image (internet access needed).

Device Information

Property	Value
Product Name	RES-5012
Communication Protocol	EtherCAT
Article Number	7501200
Serial Number	123456
Firmware	00.314
MAC Address	b8:0b:9d:00:74:da

Device Description File

[ESI file for RES-5012](#)



© 2016-2023 ROPEX Industrie-Elektronik GmbH. All rights reserved. Version 3.4

The *Home* screen contains general product information under "Device Information," e.g.

- Device name
- Serial number
- Firmware version
- MAC address
- Realtime Ethernet protocol
- For information on the GSDML file, refer to Device master file (ESI) [► 38].
The file can be downloaded directly from the internal webserver. An internet connection is not necessary.

8.6.2 Status

The screenshot shows the 'Status' page of the ROPEX interface. At the top, there are navigation tabs: Home, Status (selected), Parameters Counters, Protocol, Graphic, and Calibration. The ROPEX logo is in the top right. Below the tabs, the title 'Device Status' is displayed. On the right side, there is a small image of the physical device. The main content area is divided into three columns: 'Inputs', 'Outputs', and 'LEDs'.
Inputs: Setpoint: 0 °C.
Outputs: Actual Temperature: 25 °C (with a green progress bar), Start Temperature: - °C.
LEDs: A list of status indicators with corresponding colored circles: Autocal (grey), Output (grey), Heat (grey), Alarm (grey), ECAT Error (grey), ECAT Run (green), µC Power (green), and 24VDC Power (green).
 Below these columns, it shows 'Selected channel: 0', 'Used channel: 0', and 'Alarm code: 0 (ok)'. At the bottom left, there is a copyright notice: '© 2016-2023 ROPEX Industrie-Elektronik GmbH. All rights reserved.' and at the bottom right, 'Version 3.4'.

The *Status* screen provides an overview of the current temperature controller status.

Column	Display	Refer to section
Left	Inputs	Input data [▶ 39]
Center	Outputs	Output data
Right	Current state of device LEDs	

A green LED next to *Online* indicates whether a connection has been set up to the PLC.

8.6.3 Parameters/Counters

Home
Status
Parameters
Counters
Protocol
Graphic
Calibration

Device Parameters

All parameter values actually used by the device are listed here. Generally they are provided by the EtherCAT master at startup or changed by means of acyclic services.

Additionally the actual time and date of the internal realtime clock and all counters can be observed here.

Parameters

Parameter name	Value
Alloy/range	Rotary Coding Switch
Set achieved	10 K
Set exceeded	10 K
AUTOCAL temperature ch. 0	20 °C
AUTOCAL temperature ch. 1	20 °C
AUTOCAL temperature ch. 2	20 °C
AUTOCAL temperature ch. 3	20 °C
AUTOCAL temperature ch. 4	20 °C
AUTOCAL temperature ch. 5	20 °C
AUTOCAL temperature ch. 6	20 °C
AUTOCAL temperature ch. 7	20 °C
Heating time limit	0.0 s
Device diagnosis	on
Measure impulse duration	1.7 ms
Data format	Intel
Temperature coefficient ch. 0	1100 ppm/K
Temperature coefficient ch. 1	1100 ppm/K
Temperature coefficient ch. 2	1100 ppm/K
Temperature coefficient ch. 3	1100 ppm/K
Temperature coefficient ch. 4	1100 ppm/K
Temperature coefficient ch. 5	1100 ppm/K
Temperature coefficient ch. 6	1100 ppm/K
Temperature coefficient ch. 7	1100 ppm/K
Temperature range	300 °C
Maximum temperature	300 °C
Temperature diagnosis	off
Temperature diagnosis delay	0.0 s
Heatup timeout	0.0 s
AUTOCOMP	off
Output 1 (TO bit)	active when Act=Set
Hold mode	off
Restart delay after Reset	0.20 s
Maximum measurement pause	10 periods

Counters

Counter name	Value
Time	16:55
Date	22-Aug-2023
Operating hours	29.3 h
Total cycle counter	18
Clearable cycle counter	18
Cycle counter ch. 0	7
Cycle counter ch. 1	5
Cycle counter ch. 2	0
Cycle counter ch. 3	0
Cycle counter ch. 4	0
Cycle counter ch. 5	0
Cycle counter ch. 6	0
Cycle counter ch. 7	0

© 2016-2023 ROPEX Industrie-Elektronik GmbH. All rights reserved.
Version 3.4

The screen *Parameter/Counters* shows all of the parameter values currently in use by the temperature controller.

The column *Parameters* shows all parameter values received by the temperature controller from the EtherCAT® Master. If the parameters have been changed using acyclical services, these changes are also indicated here.

The column *Counters* shows all cycle and operating hours counters. These values can be used for statistical purposes.

Refer to section Object index [▶ 44] for further information.

8.6.4 Protocol

Home
Status
Parameters
Counters
Protocol
Graphic
Calibration

Device Protocol

The ROPEX device stores a number of events in its internal memory. These events (Autocal, clock setting, alarm) are time stamped and can be uploaded and exported to a CSV file in two different formats: a comma separated format (preferred for English Excel versions) and a semicolon separated format (preferred for German Excel versions).

If you want to export the entire device protocol then wait for the upload to complete.

The alarm codes are explained in a tooltip when you hover over the 'Alarm code' field briefly.

Total event entries: 16

Upload progress: 100%

CSV (comma)

CSV (semicolon)

Index	Timestamp	Operating hours	Cycle Counter	Channel	Reason	Alarm code
1	2023-08-22 07:51:46	22.2		9	0 Autocal	0
2	2023-08-22 07:50:14	22.1		9	0 Autocal	0
3	2023-08-22 07:48:52	22.1		9	1 Autocal	0
4	2023-08-22 07:47:57	22.1		9	1 Autocal	0
5	2023-08-22 07:47:09	22.1		9	0 Alarm	104
6	2023-08-22 07:44:10	22.0		6	1 Autocal	0
7	2023-08-22 07:40:03	22.0		5	1 Alarm	102
8	2023-08-22 07:39:03	21.9		2	1 Autocal	0
9	2023-08-22 07:34:45	21.9		0	1 Autocal	0
10	2023-08-22 07:34:05	21.9		0	0 Alarm	104
11	2023-08-22 07:33:10	21.9		0	1 Autocal	0
12	2023-08-22 07:32:38	21.8		0	0 Alarm	104
13	2023-08-22 07:31:52	21.8		0	0 Alarm	102
14	2023-08-22 07:30:59	21.8		0	0 Autocal	0
15	2023-08-22 07:29:49	21.8		0	0 Clock set	0
16	2023-08-22 01:01:48	21.8		0	0 Clock set	0

© 2016-2023 ROPEX Industrie-Elektronik GmbH. All rights reserved.
Version 3.4

In the *Protocol* screen, the error protocol for the temperature controller can be displayed and downloaded.

The total size of the protocol ("Total event entries") as well as the upload progress are shown.

All entries appear as a table. The following are shown for each entry:

- A time stamp generated by the built-in clock
- The operating hours and cycle counters
- The channel selected at this time

In addition to errors, the protocol also contains other information, such as "Clock set" or the AUTOCAL function.

When errors have been entered, an error code provides information on the cause of the errors. Refer to section Error messages [▶ 69] for further information.

Each error code is explained in a tooltip when the cursor hovers over it briefly.

The data can also be exported to a CSV file to enable further processing in other programs. Click the respective button to select a comma separated format or a semicolon separated format.

The download may take a few seconds, depending on the number of entries which are stored here. The newest results appear at the top of the list.

If any new events occur while this screen is displayed, they are not visible again until the list is refreshed by clicking on the *Protocol* menu item.

8.6.5 Graphic

Home
Status
Parameters
Counters
Protocol
Graphic
Calibration

Device Graphic

Here you can see the time curve of the latest heating impulses. The temperature values are only recorded while START is active.

The collected data can be exported to a CSV file in two different formats: a comma separated format (preferred for English Excel versions) and a semicolon separated format (preferred for German Excel versions).

Vertical lines mark the beginning of a new heatsealing impulse (START active). In the CSV data file a negative set point marks the beginning of a new heatsealing impulse.



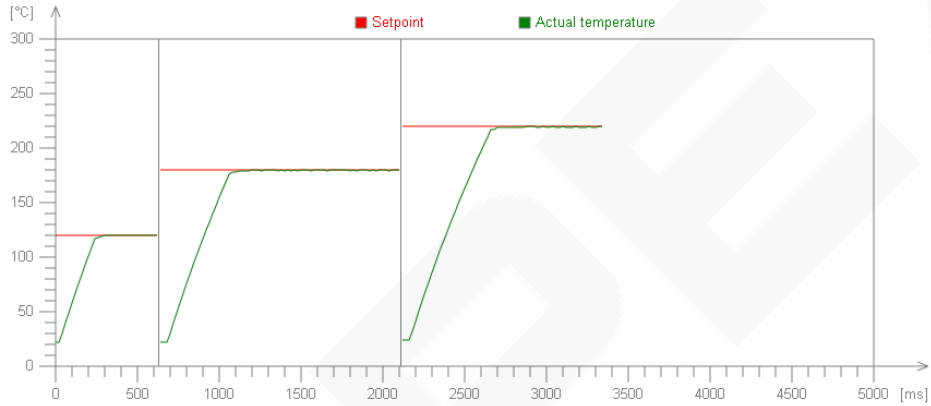

Refresh
Clear data
CSV (comma)
CSV (semicolon)

© 2016-2023 ROPEX Industrie-Elektronik GmbH. All rights reserved. Version 3.4

The temperature controller has an internal memory that can store temperature curves over a period of up to 5 seconds. This memory is automatically filled when the ST bit is set.

The memory contents can be displayed and exported in the *Graphic* screen.

Click *Refresh* to download the graphic data from the memory of the temperature controller and display it again.

Click *Clear data* or disconnect the 24 VDC supply voltage to delete all data from the memory.

The vertical lines indicate that the ST bit is set and thus the beginning of a new heatsealing pulse. A negative setpoint indicates the start of a new pulse in the exported data. Cooling processes are not normally visible, because they take place when the ST bit is being reset.

8.6.6 Calibration

Available beginning with firmware version

This function is available with firmware version 303 and higher.

Home Status Parameters Counters Protocol Graphic **Calibration**

Calibration Resistances

All calibration resistance values measured by the device are listed here. Generally they are calculated at the end of the AUTOCAL execution.

Additionally the calibration deviation values between Master AUTOCAL (→ initial calibration resistance) and normal AUTOCAL (→ calibration resistance) can be observed here.

CAUTION:

Wrong resistance values are displayed if

- external components like RV-xxxx, RB-xxxx, MSVM-x, ... are used.
- the value "Passes through current transformer" is not set correctly.

Calibration resistances

Name	Value
Passes through current transformer	1
Calibration resistance ch. 0	400.7 mΩ
Calibration resistance ch. 1	360.6 mΩ
Calibration resistance ch. 2	0.0 mΩ
Calibration resistance ch. 3	0.0 mΩ
Calibration resistance ch. 4	0.0 mΩ
Calibration resistance ch. 5	0.0 mΩ
Calibration resistance ch. 6	0.0 mΩ
Calibration resistance ch. 7	0.0 mΩ
Initial calibration resistance ch. 0	411.9 mΩ
Initial calibration resistance ch. 1	298.2 mΩ
Initial calibration resistance ch. 2	0.0 mΩ
Initial calibration resistance ch. 3	0.0 mΩ
Initial calibration resistance ch. 4	0.0 mΩ
Initial calibration resistance ch. 5	0.0 mΩ
Initial calibration resistance ch. 6	0.0 mΩ
Initial calibration resistance ch. 7	0.0 mΩ

Deviation values

Name	Value
Calibration deviation ch. 0	-2.71 %
Calibration deviation ch. 1	20.92 %
Calibration deviation ch. 2	0.00 %
Calibration deviation ch. 3	0.00 %
Calibration deviation ch. 4	0.00 %
Calibration deviation ch. 5	0.00 %
Calibration deviation ch. 6	0.00 %
Calibration deviation ch. 7	0.00 %

© 2016-2023 ROPEX Industrie-Elektronik GmbH. All rights reserved.
Version 3.4

These initial calibration resistances are the basis for the calculation of the calibration deviation. Each execution of the AUTOCAL function will calculate both the absolute calibration resistance and the proportional calibration deviation from the initial calibration resistance.

These values are shown in the *Calibration* screen.

The temperature controller saves the absolute calibration resistance of each channel (calibration resistance ch. 0...7) with a resolution of 0.1 mΩ.

The calculation of the respective calibration resistance is done at the end of the AUTOCAL function; refer to section Automatic zero calibration AUTOCAL (AC) [▶ 39].

The initial calibration resistances ch. 0...7 are calculated if the master AUTOCAL function is executed; refer to section Master AUTOCAL (MA) [▶ 42].

Additionally the actual value of "passes through current transformer" is displayed. This value can be read or written by means of acyclical services. In order to be able to calculate the absolute resistance values, the value indicating the actual passes through the current transformer has to be the same. This value has no influence on the calculation of the proportional calibration deviation.

Note The calculation of the absolute resistance values is susceptible to fluctuations. Causes of fluctuations are e.g.

- Tolerances in production
- Application dimensioning
- Quality of cabling
- Fluctuations in the power supply
- Actual temperature of the heat-sealing band

8.7 Undervoltage detection



NOTICE

Property damage due to insufficient line or 24 VDC supply voltage

A line or 24 VDC supply voltage that is too low can lead to faulty sealing.

- ▶ Use an external voltage monitoring device

Prerequisite Trouble-free operation of the temperature controller is guaranteed within the line voltage and 24 VDC supply tolerance range specified in section Technical data [▶ 78].

If the 24 VDC supply voltage drops below the permitted lower limit, the temperature controller switches to standby mode. No more heat-sealing processes take place and no more measuring pulses are generated. Normal operation resumes when the input voltage returns to the specified tolerance range again.

Standby mode is indicated by 0...3 °C (i.e. approx. 0 V) at the analog output. In addition, the SA bit is set in the status word for the cyclical output data.

8.8 Analog temperature display

The temperature controller supplies an analog voltage signal 0...10 VDC at the terminals 17+18. The voltage signal is proportional to the actual temperature.

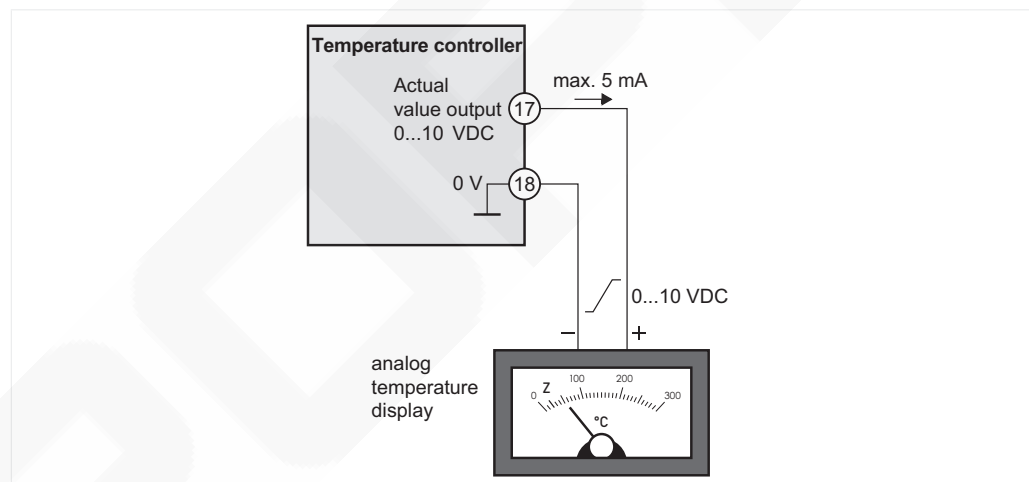

Illustration 14: Example of temperature controller with analog temperature display

A display instrument can be connected to the actual value output to show the heat-sealing band temperature.

The analog temperature display can be used e.g.

- To compare the setpoint to the actual temperature.
- To specify the heat-up rate.
- To check whether the setpoint is reached within the required time.
- To observe how the heat-sealing band cools off.
- To detect disruptions in the control circuit (loose connections, contact and cabling problems, power disruptions).
- To detect adjacent control loops that disturb one another.

When an alarm occurs, the analog output shows differentiated error messages; refer to Error messages [▶ 69].

8.9 USB interface



Illustration 15: USB interface

The temperature controller has a USB interface.

The micro USB interface enables a data connection to be set up to *ROPEXvisual*[®], the ROPEX visualization software.

The visualization software is used for system diagnostics and process visualization.

Downloads Further information can be found in the operating instructions for the visualization software *ROPEXvisual*[®]. The operating instructions and software can be found on the ROPEX website, under Downloadbereich.

Menu path Products > Downloads > REGISTER

Tip Enter the search term "visual."

8.10 AUX interface



The temperature controller has an AUX interface.

The AUX interface is used for diagnostics and maintenance purposes.

8.11 Total cycle counter

The number of heat-sealing cycles executed since the temperature controller was delivered is saved in the internal memory (ST bit = 1).

This is a read-only counter and cannot be reset.

It can be displayed:

- With the visualization software; refer to the operating instructions for *ROPEXvisual*[®].
- Via the integrated webserver; refer to section Parameters/Counters [▶ 60]
- Using the acyclical service of the EtherCAT[®] interface; refer to section Object index [▶ 44]

8.12 Operating hours counter

The number of operating hours since the temperature controller was delivered is saved.

This is a read-only counter and cannot be reset.

The counter works with a resolution of 6 minutes.

It can be displayed:

- With the visualization software; refer to the operating instructions for *ROPEXvisual*[®]
- Via the integrated webserver; refer to section Parameters/Counters [▶ 60]
- Using the acyclical services of the EtherCAT[®] interface; refer to section Object index [▶ 44]

8.13 Data memory

To simplify error diagnoses during operation, the RES-5010 controller has a data memory for:

- Error messages; refer to section Error messages [▶ 69]
- AUTOCAL processes; refer to section Automatic zero calibration AUTOCAL (AC) [▶ 39]
- The integrated clock; refer to section Built-in clock [▶ 66]
All messages are saved in the data memory, along with the date and time of occurrence (time stamp). If the time or date is changed via the visualization software or acyclical services, an entry in the protocol is made in the data memory.

The 400 most recent messages are stored.

These messages can be displayed:

- With the visualization software; refer to the operating instructions for *ROPEXvisual*[®]
- Via the integrated webserver; refer to section Protocol [▶ 61]

Note The stored messages can be exported as a csv-file. If needed, ROPEX can evaluate the exported file and create an error diagnosis.

8.14 Built-in clock

The temperature controller has a built-in clock.

All messages are saved in the data memory, along with their date and time of occurrence (time stamp); refer to section Data memory [▶ 66] Error messages can thus be accurately correlated whenever a problem needs to be analyzed.

The built-in clock can be set and read out using:

- The visualization software; refer to the operating instructions for the visualization software *ROPEXvisual*[®]
- The acyclical services of the EtherCAT[®] interface

The built-in clock can be read out using:

- The integrated webserver; refer to section Parameters/Counters [▶ 60]

A maintenance-free capacitor is used to operate the clock. No battery is needed for operation.

The temperature controller must remain switched on for at least 3 hours to make sure the clock's capacitor is fully charged. When the temperature controller is switched off, the fully charged capacitor can keep the clock running for approximately 2 to 4 weeks. If the temperature controller is switched off for longer, the date and time will have to be set again.

The capacitor is not charged when it leaves the factory. If the error messages are to be saved in the data memory along with their date and time of occurrence, set the clock when starting up the temperature controller.

The temperature controller can be operated even when the clock is not set. In this case, the dates and times that are saved in the data memory will be invalid. This does not, however, impact how the temperature controller behaves.

9 Monitoring and error detection

9.1 System monitoring and alarm output

To increase operational safety and prevent faulty heat-sealing, the temperature controller monitors both external wiring as well the internal system.

Error messages and diagnoses are detected by means of hardware and software applications. This allows the source of faulty operation of the temperature controller to be localized.

A system fault is reported or differentiated by means of the following indications.

Who reports?	How is the fault reported?	Meaning
Red ALARM LED on temperature controller	Flashes quickly (4 Hz)	<ul style="list-style-type: none"> Execute AUTOCAL functions (error codes 104...106, 211, 302, 303). <p>Note: If a START signal is sent during this state, the LED remains illuminated.</p>
	Flashes slowly (1 Hz)	<p>The system configuration is incorrect and the zero calibration (AUTOCAL function) was unsuccessful (error codes 111...114); refer to section Temperature controller configuration [▶ 32].</p> <p>Note: If a START signal is sent during this state, the LED remains illuminated.</p>
	Illuminated continuously	<p>Indicates that there are faults that prevent startup (error codes 101 ...103, 107, 108, 201...203, 304, 307, 308, 9xx).</p> <p>Tip There are usually external wiring faults.</p>
Alarm relay (relay contact terminals 12+13+14) default ¹⁵	NOT ACTIVE	<ul style="list-style-type: none"> When the red ALARM LED on the temperature controller flashes quickly. When the red ALARM LED on the temperature controller flashes slowly.
	ACTIVE	<ul style="list-style-type: none"> When the red ALARM LED on the temperature controller remains illuminated.
Error code indicated via the EtherCAT® protocol.	The error code is contained in the third word at bit positions 0...9; refer to section Error code.	If an error occurs, the AL bit is set and possibly also the WA bit.
Error code indicated via the actual value output 0...10 VDC (terminals 17+18)	13 voltage levels	<p>Since a temperature indication is no longer necessary if a fault occurs, the actual value output is used to display error messages whenever a fault is signaled. Instead, 13 voltage levels between 0...10 VDC are output. The voltage levels are assigned to groups of error codes; refer to section Error messages [▶ 69].</p>

¹⁵ If the alarm relay has a different configuration than the default, the states are reversed; refer to section Alarm relay configuration [▶ 34].

Who reports?	How is he fault reported?	Meaning
Error code indicated via the actual value output 0...10 VDC (terminals 17+18)	Error codes	For statuses that require AUTOCAL, or if the device configuration is incorrect (error codes 104...106, 111...114, 211, 302, 303), the signal at the actual value output alternates at 1 Hz between the voltage value corresponding to the error and the end of the scale (10 VDC, i.e. 300 °C or 500 °C). If the START signal is present in one of these states, the voltage value does not change any more.
	Temperature display	If a temperature meter is connected to the temperature controller's analog output, the temperature indication can be directly assigned to the group of the error codes.

Activating alarm messages The alarm message can be reset by activating the RS bit or by switching the temperature controller on/off (24 VDC supply). If an error message is reset with the RS bit, it is not actually reset until the RS bit is deactivated.

Tip Invalid error messages may appear when the temperature controller is switched off owing to the undefined operating state. This must be taken into account when they are evaluated by the higher-level controller (e.g. a PLC) in order to avoid false alarms.

9.2 Error messages

The error messages are encoded and saved in the protocol.

The error diagnosis can also be accessed as follows:

- The "Diagnosis history" object can be accessed.
The error messages appear in a list as plain text and with a time stamp.

Tip To facilitate error diagnosis, the temperature controller emits 13 voltage levels via the analog output. In the temperature controller, the error messages are more precisely differentiated and encoded as error codes.

The three-digit error codes can be displayed as follows:

- Webserver
- EtherCAT® interface
- For information on the visualization software, refer to the operating instructions for the visualization software ROPEXvisual®.

Notes In order to avoid incorrect evaluations, the evaluation of the analog output for the detection of an error message – e. g. in the higher-level control unit – must be carried out with an adapted tolerance window.

Comply with the analog output tolerances; refer to Technical data [► 78].

The following three tables show the assignment of the three-digit error codes to the voltage level at the analog output. They also contain the causes and the measures required to remedy the error.

9.2.1 Part 1 of 3: Troubleshooting

The errors are reported as faults.

- The analog output emits constant voltage, the level of which is associated with a set of error codes.
- ALARM LED remains illuminated.
- Alarm relay is active.

Error code	Analog output voltage [V]	Cause	Action if heat-sealing band is started for the first time or replaced	Action if machine is already in operation, heat-sealing band not changed
101	0.66	No current signal	Fault area 1 ¹⁷⁾	
102	1.33	Voltage signal missing	Fault area 3 ¹⁷⁾	
103	2.00	Voltage and current signals missing	Fault area 2 ¹⁷⁾	Fault area 2 and 9 ¹⁷⁾
107	2.66	Temperature drop	And/or fault areas 4 , 5 and 6 (loose contact) ¹⁷⁾ <ul style="list-style-type: none"> ▶ Check dimensioning of the pulse transformer. ▶ Check heat extraction through the sealing process. ▶ Verify application through sealing tests. 	
108		Temperature spike		
307		Temperature too low, tolerance range was left		
308		Temperature too high, tolerance range was left		
309		Temperature too low, tolerance range was not reached		
310		Temperature too high, tolerance range was not reached		
201	3.33	Line frequency missing/fluctuates	<ul style="list-style-type: none"> ▶ Check mains power supply: <ul style="list-style-type: none"> • Line frequency • Harmonics • Voltage fluctuations 	
202		Line frequency too high / fluctuates		
203		Line frequency too low / fluctuates		
304	4.00	Heat-up time too long	<ul style="list-style-type: none"> ▶ Reset device ▶ Check dimensioning of the pulse transformer. ▶ Check parametrized heating time. ▶ Check lines and contacting. 	<ul style="list-style-type: none"> ▶ Reset device ▶ Check lines and contacts. ▶ Check sealing process.
305		Start temperature too high	<ul style="list-style-type: none"> ▶ Reset device ▶ Check cooling system. ▶ Check maximum start temperature. 	
901	4.66	Line voltage / synchronizing signal missing	▶ Check line voltage	
913		Triac defective	▶ Replace device.	
914		Internal error: Comparator in measuring module defective		
915				
916		Internal error: Test mode not ended successfully		
917		Slide for alarm output not plausible	▶ Check slide.	
918				
919	Internal error: Comparator in measuring mode not plausible	▶ Replace device.		

¹⁷⁾ Refer to the wiring diagram Fault areas and causes [▶ 73] for further information.

Error code	Analog output voltage [V]	Cause	Action if heat-sealing band is started for the first time or replaced	Action if machine is already in operation, heat-sealing band not changed
920	4.66	Voltage signal not plausible <ul style="list-style-type: none"> Internal error: Voltage change-over in measuring module defective 	<ul style="list-style-type: none"> ▶ Check heating circuits: <ul style="list-style-type: none"> • Check relay Kb. • Check voltage signal. • Do not interrupt voltage signal during AUTOCAL. ▶ Reset device ▶ Restart AUTOCAL. ▶ Replace device. 	
930		Internal communication module does not reply when temperature controller is switched on	<ul style="list-style-type: none"> ▶ Switch device off and then on again. ▶ If the error code appears repeatedly, replace device. 	
931		Internal communication module indicates an error when temperature module is switched on		
932		Internal communication module does not reply during operation		
933		Internal communication module indicates an error during operation		
934		Internal communication module does not reply during operation		
935		Communication module firmware is not plausible (does not match device type)	<ul style="list-style-type: none"> ▶ Replace device. 	
937		Internal communication module not started correctly	<ul style="list-style-type: none"> ▶ Switch device off and then on again. ▶ If the error code appears repeatedly, replace device. 	
938		Internal error: Capacitor in measuring module defective	<ul style="list-style-type: none"> ▶ Replace device. 	
939				
940				
941 ¹⁶⁾				

9.2.2 Part 2 of 3: Troubleshooting

The errors are initially reported as warnings.

- Analog output alternates between two values.
- ALARM LED flashes at 4 Hz.
- Alarm relay not active.

After the START signal is activated, the errors are reported as faults.

- Analog output no longer alternates; refer to bold value (e.g. **5.33**).
- ALARM LED remains illuminated.
- Alarm relay is active.

¹⁶⁾ Available beginning with firmware 313

Error code	Analog signal voltage [V] ¹⁸⁾	Error message and cause	Action if heat-sealing band started for the first time	Action if machine is already in operation, heat-sealing band not changed
104	5.33/10	Current signal incorrect: <ul style="list-style-type: none"> • Pulse transformer incorrectly dimensioned 	<ul style="list-style-type: none"> ▶ Perform AUTOCAL. ▶ Check transformer specifications. 	Refer to fault areas 4 , 5 and 6 (loose wire) ¹⁹⁾
105		Voltage signal incorrect: <ul style="list-style-type: none"> • Pulse transformer incorrectly dimensioned 	Refer to fault areas 7 and 8 ¹⁹⁾	
106		Voltage and current signal incorrect: <ul style="list-style-type: none"> • Pulse transformer incorrectly dimensioned 		
302		Temperature too low: <ul style="list-style-type: none"> • Calibration not performed • Loose contact • Ambient temperature fluctuates 	<ul style="list-style-type: none"> ▶ Perform AUTOCAL. And/or fault areas 4 , 5 and 6 (loose contact): ¹⁹⁾	
303	Temperature too high: <ul style="list-style-type: none"> • Calibration not performed • Loose contact • Ambient temperature fluctuates 			
211	6.00/10	Data error	▶ Perform AUTOCAL .	

9.2.3 Part 3 of 3: Troubleshooting

Note This section shows error messages that may occur if the AUTOCAL function is not ended properly.

The errors are initially reported as warnings.

- Analog output alternates between two values.
- ALARM LED flashes at 1 Hz.
- Alarm relay not active.

After the START signal is activated, the errors are reported as faults.

- Analog output no longer alternates; refer to bold value (e.g. **6.66**).
- ALARM LED remains illuminated.
- Alarm relay is active.

¹⁸⁾ The voltage at the analog output alternates between the two values.

¹⁹⁾ Refer to the wiring diagram Fault areas and causes [▶ 73] for further information.

Error code	Analog signal voltage [V] ²⁰⁾	Cause	Action if heat-sealing band started for the first time	Action if machine is already in operation, heat-sealing band not changed
111	6.66/10	Current signal incorrect, calibration not possible	Fault area 8 ²¹⁾ ▶ Check configuration.	Fault areas 4, 5 and 6 (loose wire) ²¹⁾
112	7.33/10	Voltage signal incorrect, calibration not possible	Fault area 7 ²¹⁾ ▶ Check configuration.	
113	8.00/10	Voltage and current signal incorrect, calibration not possible	Fault areas 7 and 8 ²¹⁾ ▶ Check configuration	
114	8.66/10	Temperature fluctuates, calibration not possible	▶ Perform AUTOCAL And/or fault areas 4, 5 and 6 (loose contact) ²¹⁾	
115		External calibration temperature too high, calibration not possible	▶ Perform AUTOCAL with external calibration temperature ≤ 40 °C.	
116		External calibration temperature fluctuates, calibration not possible	▶ Perform AUTOCAL with stable external calibration temperature.	

9.3 Fault areas and causes

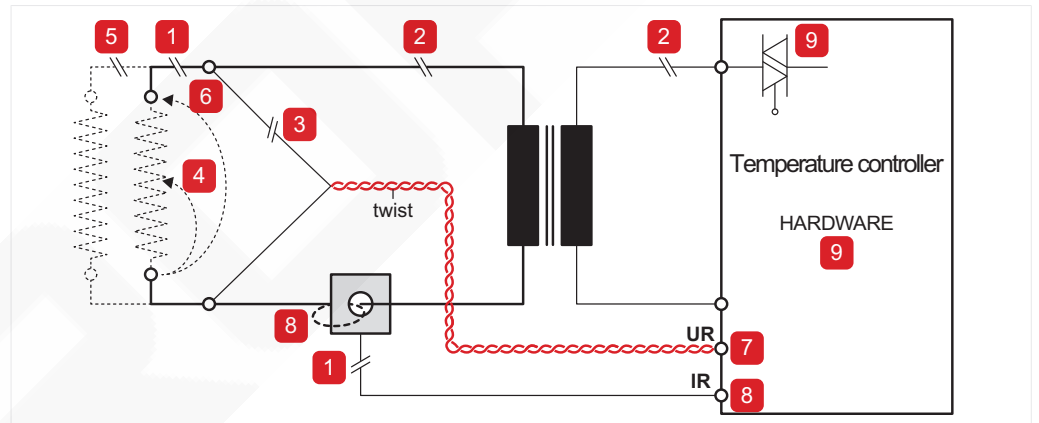

Illustration 16: Fault areas and causes

The following table explains the possible causes.

Fault area	Explanation	Possible causes
1	Load circuit interrupted after U _R pickup point	<ul style="list-style-type: none"> • Wire break, heat-sealing band break. • Contact to heat-sealing band is defective.
	Current transformer signal interrupted	<ul style="list-style-type: none"> • I_R measurement cable from current transformer interrupted.
2	Primary circuit interrupted	<ul style="list-style-type: none"> • Wire break, triac in controller defective. • Primary winding of pulse transformer interrupted. • Kb contactor open.

²⁰⁾ The voltage at the analog output alternates between the two values.

²¹⁾ Refer to the wiring diagram Fault areas and causes [▶ 73] for further information.

Fault area	Explanation	Possible causes
2	Secondary circuit interrupted before U_R pickup point.	<ul style="list-style-type: none"> • Wire break • Secondary winding of pulse transformer interrupted.
3	No U_R signal	<ul style="list-style-type: none"> • Measurement cable interrupted.
4	Partial bypass (delta R)	<ul style="list-style-type: none"> • Heat-sealing band partially bypassed by conducting part, e.g. clamp, opposite heat-sealing bar.
5	Parallel circuit interrupted	<ul style="list-style-type: none"> • Wire break, heat-sealing band break. • Contact to heat-sealing band is defective.
6	Total bypass	<ul style="list-style-type: none"> • Heat-sealing band incorrectly installed, no insulation at heat-sealing bar ends or insulation incorrectly installed. • Heat-sealing band completely bypassed by conducting part.
7	U_R signal incorrect	<ul style="list-style-type: none"> • Secondary voltage U_2 outside of permissible range of 0.4...120 VAC.
8	I_R signal incorrect	<ul style="list-style-type: none"> • Current I_2 outside of permissible range of 30...500 A.
	Turns incorrectly laid through current transformer	<ul style="list-style-type: none"> ▶ Check number of turns: Two or more turns required for currents < 30 A.
9	Internal device fault / no line voltage	<ul style="list-style-type: none"> • Hardware fault: ▶ Replace temperature controller. • Jumper for alarm relay defective or not in correct position. • No line voltage.

10 Replacing heat-sealing band



⚠ WARNING

Hot surfaces pose a risk of burns

The heat-sealing band is hot when it is operating.

- ▶ Allow all system components to cool off.

Replace the heat-sealing band in the event of:

- Mechanical defects, bending or deformation
- Scaled or oxidized heat-sealing band ends
- Burned in residue
- Damaged coatings, e.g. copper or Teflon surfaces

Prerequisite The following requirements have to be met:

- The heat-sealing band is cooled to ambient temperature.
- All of the components near the heat-sealing band have cooled off:
 - Silicone
 - PTFE cover
 - Sealing bar

To change the heat-sealing band, proceed as follows:

1. Disconnect the supply voltage from the temperature controller (all-pole), verify that the circuit is de-energized and secure to prevent being switched on again.
 2. Remove heat-sealing band.
 3. Install heat-sealing band.
 4. Burn in the device.
Information can be found in the sections Burning in heat-sealing band [▶ 34] and Automatic zero calibration AUTOCAL (AC) [▶ 39].
 5. To compensate for production-related tolerances of the heat-sealing band resistance, perform zero calibration with the function AUTOCAL every time the heat-sealing band is replaced.
 6. Check and adjust the temperature coefficients if necessary.
- ⇒ After replacing the heat-sealing band, burn it in and perform zero calibration.

10.1 Restarting device after changing heat-sealing band



NOTICE

Damage to heat-sealing band caused by overheating

Using unsuitable alloy, dimensions and copper coating will cause the heat-sealing band to overheat and malfunction.

- ▶ Select the proper alloy, dimensions and copper coating.

When the heat-sealing band has been replaced, the temperature controller has to be started up again and the function AUTOCAL performed. Details can be found in section Startup [▶ 28].

11 Maintenance



NOTICE

Dust deposits can impair proper functioning.

Dust can hinder proper functioning of the temperature controller.

- ▶ When it is de-energized, dust can be removed from the temperature controller with dry compressed air.
- ▶ Install a temperature controller in the electrical cabinet or terminal box for protection class IP 54 or higher.



NOTICE

Contamination with liquids can impair proper functioning

Contamination with liquids can hinder proper functioning of the temperature controller.

- ▶ Install a temperature controller in the electrical cabinet or terminal box for protection class IP 54 or higher.

The temperature controller requires no special maintenance.

Regular inspection and/or tightening of the terminals – including the terminals for the winding connections on the pulse transformer – is recommended.

12 Disposal

This device is subject to directive 2012/19/EU concerning the reduction of the increasing amount of waste of electrical and electronic equipment and the disposal of such waste in an environmentally sound way.

To guarantee proper disposal and/or to recover reusable materials, please take the device to a designated municipal collection point for electrical and electronic devices.

Observe local regulations.

The device can also be returned to the manufacturer instead.

The device shall not be disposed of as residual waste.

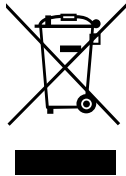

13 Technical data

13.1 Technical data



NOTICE

Risk of defects and loss of warranty when operation of the device does not comply with technical specifications

Operating the device in noncompliance with the technical specifications can cause defects and result in loss of warranty.

- ▶ Comply with the technical specifications.

Device	Technical data
Type of construction	<ul style="list-style-type: none"> • Installation in an electrical cabinet • Snaps onto a standard top hat rail TS35 (35 mm) pursuant to EN 50022
Dimensions	Base area 90 × 75 mm Housing depth: 113 mm Depth including terminals: 135 mm
Line voltage	<ul style="list-style-type: none"> • Connected between neutral conductor and an outer conductor: <ul style="list-style-type: none"> • 110 VAC -15 %...300 VAC +10 % or • Connected between two outer conductors: <ul style="list-style-type: none"> • 5010, 01: 110 VAC -15 %...415 VAC +10 % • Beginning 02/2021: 110 VAC -15 %...480 VAC +10 % Note: The voltage between the line conductor and ground shall not be more than 300 VAC.
Power supply system	<ul style="list-style-type: none"> • Balanced TN or TT system • Installation category III Note: Operation in an IT system is permitted only in agreement with ROPEX. Consult ROPEX, e-mail i
Line frequency	47...63 Hz automatic adjustment to frequencies in this range
Current consumption max. (primary current of pulse transformer)	<ul style="list-style-type: none"> • $I_{max} = 5 \text{ A}$ (duty cycle = 100 %) • $I_{max} = 25 \text{ A}$ (duty cycle = 20 %, cycle duration 1 min)
Supply voltage Terminals 5+7	<ul style="list-style-type: none"> • 24 VDC, $I_{max} = 200 \text{ mA}$ (control mode), 1 A (switch-on current) Tolerance: $\pm 10 \%$ • SELV or PELV supplied from max. 300 VAC, Cat II
Measuring range	<ul style="list-style-type: none"> • Secondary voltage U_R: 0.4...120 VAC • Secondary current I_R: 30...500 A (with current transformer PEX-W5) Refer to the application report for more information.
EtherCAT® interface	<ul style="list-style-type: none"> • 2 Ethernet switch ports RJ45 • Wiring: IEC 61784-5-3 • Data transfer rate: 100 Mbit/s • Data transport layer: Ethernet II, IEEE 802.3 • Addressing: automatically via topology, coding dial

Device	Technical data
Heat-sealing band type and temperature range	Temperature range and temperature coefficient can be set via: <ul style="list-style-type: none"> The coding dial or the EtherCAT® interface; refer to section and Temperature range and alloy [► 50] Visualization software; refer to section USB interface [► 65] The following parameters can be set: <ul style="list-style-type: none"> Temperature range: 200 °C, 300 °C, 400 °C or 500 °C Temperature coefficient: 400...4000 ppm/K (variable setting range) Refer to the application report for the proper setting.
Analog output (actual value) Terminals 17+18	0...10 VDC, $I_{\max} = 5 \text{ mA}$ Equivalent to 0...300 °C or 0...500 °C Accuracy: $\pm 1 \%$ plus 50 mV
Alarm relay Terminals 12, 13, 14	$U_{\max} = 30 \text{ V (DC/AC)}$, $I_{\max} = 1 \text{ A}$, changeover contact, potential-free (for UL certification: $I_{\max} = 0.2 \text{ A}$)
Power loss	max. 20 W
Ambient conditions	<ul style="list-style-type: none"> Max. altitude: 2000 m Ambient temperature: +5...+45 °C Maximum relative humidity: 80% at temperatures up to +31 °C, decreasing linearly to 50% relative humidity at +45 °C.
Degree of protection	IP20
Protection class	Protection class I
Certification	UL, E464680
Weight	Approx. 0.5 kg (incl. Terminal strip)
Housing material	Plastic, polycarbonate, UL-94-V0
Connecting cable (type / cross sections)	<ul style="list-style-type: none"> Rigid or flexible; 0.2...2.5 mm² (AWG 24...12) plug-in terminals Plug-in terminals: Torque: 0.5...0.6 Nm (screwdriver: SZS 0.6x3.5 mm) Note: If ferrules are used, they must be crimped in accordance with DIN 46228 and IEC / EN 60947-1. This is essential to ensure proper electrical contact in the terminals.

13.2 Modification



Owing to its universal design, the temperature controller is suitable for a wide range of heat-sealing applications.

There are device modifications available for special applications (MOD).





The modifications must be ordered separately.

Modification	Function	Use
MOD 01	Additional booster for low secondary voltage ($U_R = 0.2...60 \text{ VAC}$).	Essential e.g. when using very short or low-resistance heat-sealing bands.

13.3 How to order

Illustration	Device	Article number
	Temperature controller RES-5012	7501200
	Modification MOD ... (optional) Example: MOD 01 additional booster for low voltage ²³⁾	800001
System components		
	Current transformer PEX-W5	885107
	Line filter LF-06480 Continuous current 6 A, 480 VAC (with UL certification)	885500
	Line filter LF-35480 Continuous current 35 A, 480 VAC	885506
	Line filter LF-10520 Continuous current 10 A, 520 VAC (with UL and CSA certification)	885504
	Line filter LF-20520 Continuous current 20 A, 520 VAC (with UL and CSA certification)	885510
	Line filter LF-30520 Continuous current 30 A, 520 VAC (with UL and CSA certification)	885511
	Line filter LF-50520 Continuous current 50 A, 520 VAC (with UL and CSA certification)	885509
	Pulse transformer <ul style="list-style-type: none"> • For design and order specifications, refer to the application report • Design pursuant to EN 61558 • Available with UL certifications and thermal switch, if necessary. 	
	Booster B-075480 pulse loaded 75 A, 480 VAC	885306
	Booster B-100400 pulse loaded 100 A, 400 VAC	885304
	Booster B-100480 pulse loaded 100 A, 480 VAC	885307

²³ Example:
To order a temperature controller with additional booster for low voltage: RES-5012 + MOD 01
The order is then: Art. no. 7501200 + 800001.

Illustration	Device	Article number
	Lines	For design and order specifications, refer to the application report
Accessories		
	High-current rail HCB-1 <ul style="list-style-type: none"> Optional for current transformer PEX, when the cable cross-section is too large 	885110
	Current balance monitor CBM-2	885217
	High-current rail HCB-2 <ul style="list-style-type: none"> Optional for CBM-2, when the cable cross-section is too large 	885218
	Upstream transformer An upstream transformer can be individually designed and supplied upon request.	

EU Declaration of Conformity

The Manufacturer

ROPEX Industrie-Elektronik GmbH
 Adolf-Heim-Str. 4
 74321 Bietigheim-Bissingen
 Germany

hereby declare that the following product

Designation	RESISTRON® and CIRUS® temperature controller		
Type	RES-5006	Article number	7500600
	RES-5007		7500700
	RES-5008		7500800
	RES-5009		7500900
	RES-5010		7501000
	RES-5011		7501100
	RES-5012		7501200
	RES-5027		7502700
	UPT-6006		7600600
	UPT-6010		7601000
	UPT-6011		7601100
	UPT-6012		7601200
Operating principle	Impulse sealing of films and plastics		

is in conformity with the provisions of the following EU directives (inclusive amendments)

- 2014/30/EU Electromagnetic Compatibility Directive (EMC Directive)
- 2014/35/EU Directive on electrical equipment designed for use within certain voltage limits (Low Voltage Directive)
- 2011/65/EU Directive on the use of certain hazardous substances in electrical and electronic equipment (RoHS Directive)

References of standards for this declaration of conformity, or parts thereof:

Harmonized standards of Europe:

- Safety
 - EN 61010-1:2010+A1:2019 Safety requirements for electrical equipment for measurement, control, and laboratory use - Part 1: General requirements
 - EN 61010-2-030:2021-04 Safety requirements for electrical equipment for measurement, control, and laboratory use - Part 2-030: Particular requirements for equipment having testing or measuring circuits
- Electromagnetic compatibility
 - EN 61000-6-2:2005-08+AC:2005-12 Electromagnetic compatibility (EMC) - Part 6-2: Generic standards - Immunity standard for industrial environments (Immunity: Severity level industrial)
 - EN 61000-6-4:2007-09+A1:2011-09 Electromagnetic compatibility (EMC) - Part 6-4: Generic standards - Emission standard for industrial environments (Emission: Limit class A)
- Restriction of hazardous substances
 - EN 63000:2018 Technical documentation for the assessment of electrical and electronic products with respect to the restriction of hazardous substances

Note

This declaration of conformity certifies that the product itself complies with the above-mentioned directives.

The CE mark on the product does not relieve the machinery manufacturer of his duty to verify the conformity of the completely installed, wired and operationally ready system in the machine with the EMC directive.

Comments

RESISTRON® and CIRUS® temperature controllers with accessories are not independently operable devices. They are used by the machinery manufacturer to form a sealing system by adding EMC-relevant components such as filters, transformers, heatsealing bands and wiring. The final configuration may vary significantly in terms of performance and physical dimensions.

All information provided by us in connection with the line filter is merely intended as a guide and is based on a typical system setup. It serves to demonstrate that compliance with the EMC directive can be achieved by using a line filter that is suitable for the overall system.

The line filter and current transformer must, however, be determined on the basis of the respective application.

We also wish to point out that the transformer which is used must be designed in accordance with VDE 0551/ EN 61558 or UL 5085 for safety reasons.

Bietigheim-Bissingen, August 15, 2023

i.U.



Uwe Dietrich | Director Research & Development

15 Appendix

The following pages show examples for the arrangement and wiring of the system components in the electrical cabinet as well as examples comparing the right way and wrong way to wire the devices.

Copying of this document and giving it to others, and the use or communication of the contents thereof, are forbidden without express authority. All rights reserved.

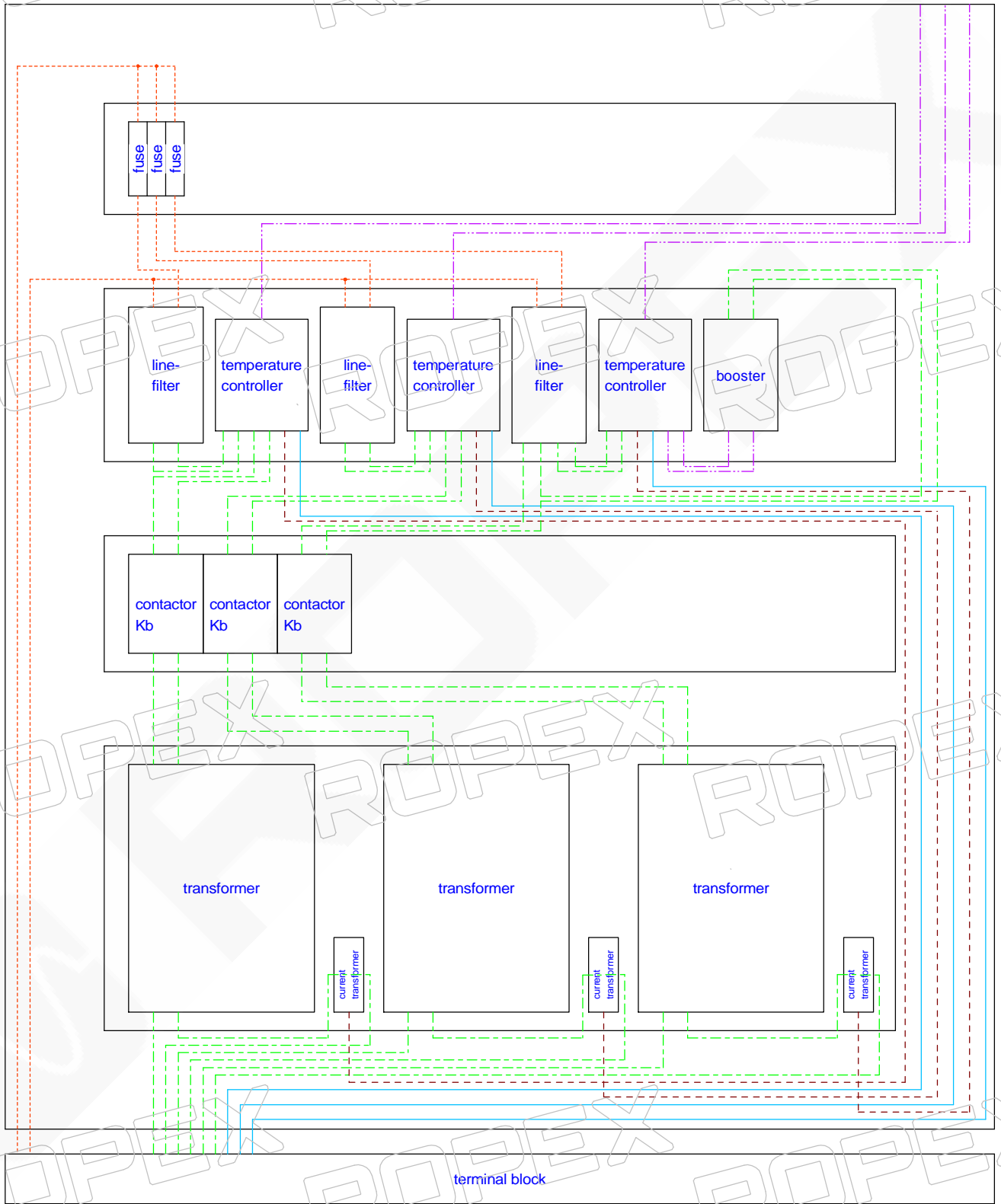

- legend:
- - - - - not filtered
 - - - - - filtered
 - - - - - IR measurement
 - - - - - UR measurement
 - - - - - control wires to PLC

Weitergabe und Vervielfältigung dieser Unterlage, sowie Verwertung und Mitteilung ihres Inhalts nicht gestattet, soweit nicht ausdrücklich zugestanden. Alle Rechte vorbehalten

15.2 Examples of electrical connections

Connection to one heat-sealing band

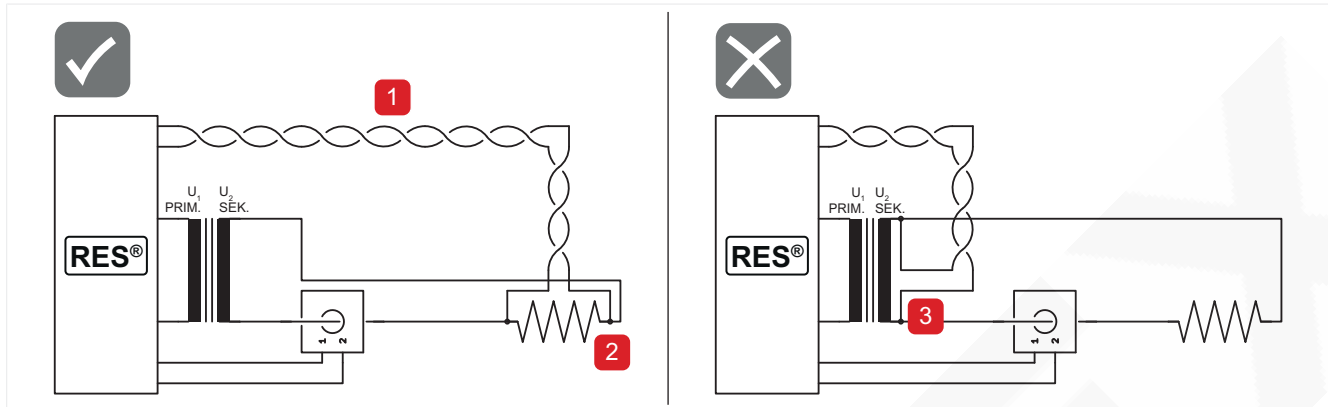

Illustration 17: Component wiring, example 1

- Example 1**
- ▶ Connect the measurement cable (1) directly to the heat-sealing band.
Background information: To prevent measurement errors caused by unintentionally measuring the line resistances, do not connect to the pulse transformer (3).
 - ▶ Lay the lines going in opposite directions close together.

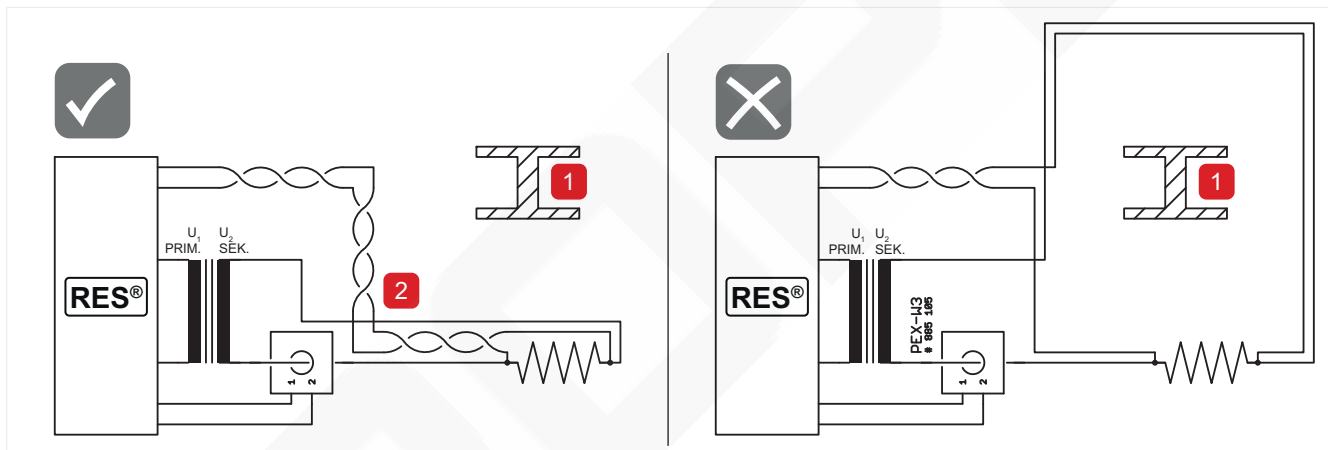

Illustration 18: Component wiring, example 2

- Example 2**
- ▶ When objects have to be circumvented, especially iron or steel parts such as I-beams (1), lay the lines going in opposite directions on the same side whenever possible.
 - ▶ Laying measuring cable (2) as twisted pair.

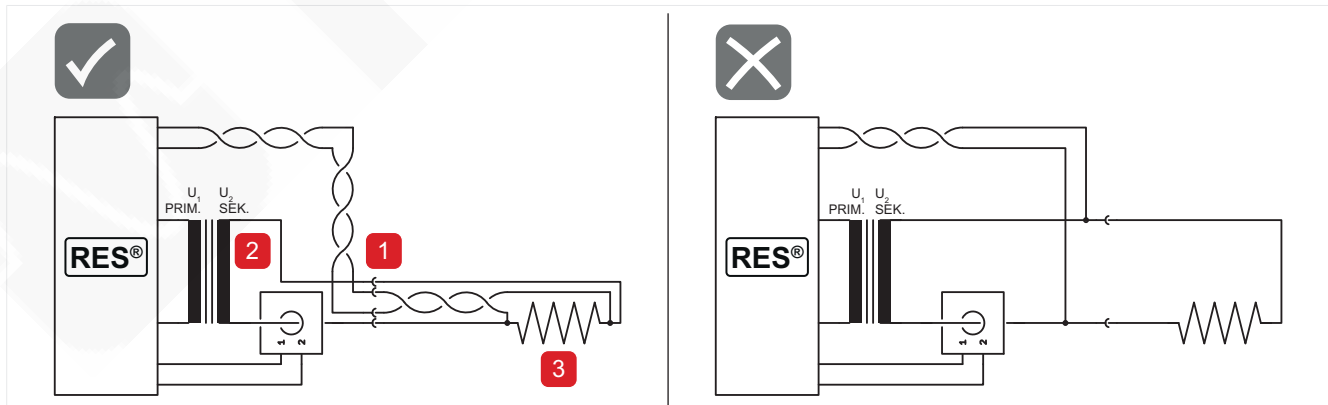

Illustration 19: Component wiring, example 3

Example 3 If plug connectors or clamping points (1) have to be installed between the pulse transformer (2) and the heat-sealing band, the measurement cable has to be connected with its own clamping points. This prevents measurement errors caused by low contact resistances in the clamping points.

Parallel connection

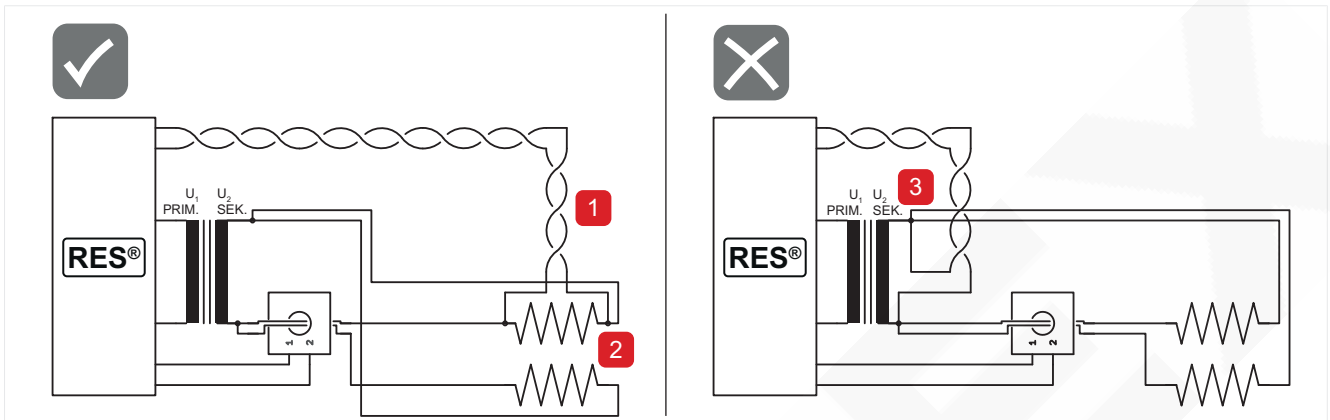

Illustration 20: Component wiring, example 4

Example 4 ▶ Connect the measurement cable (1) directly to one of the two heat-sealing bands (2).
Background information: To prevent measurement errors caused by measuring the supply line resistance, do not connect to the pulse transformer (3).

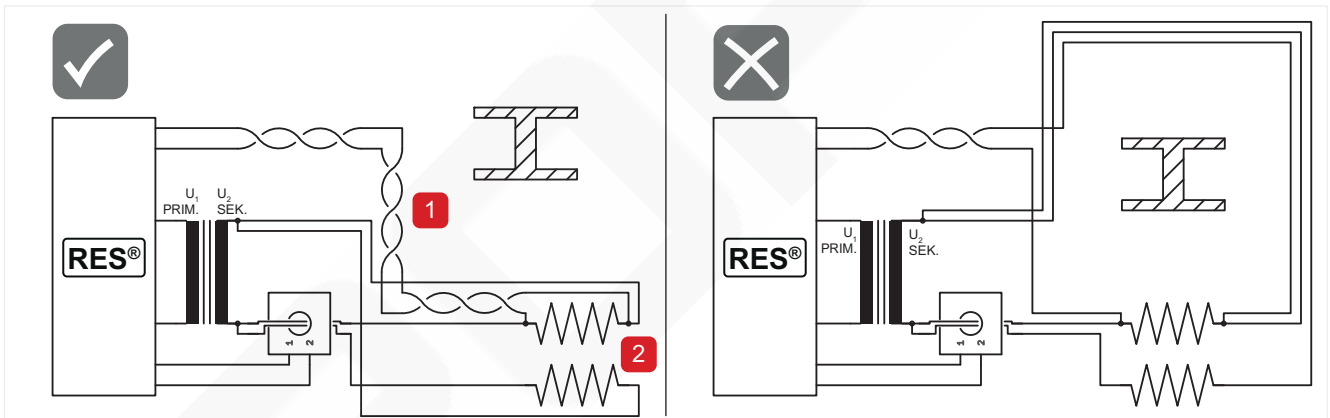

Illustration 21: Component wiring, example 5

Example 5 ▶ When objects have to be circumvented, especially iron or steel parts such as I-beams (1), lay the lines going in opposite directions on the same side whenever possible.

► Laying measuring cable (2) as twisted pair.

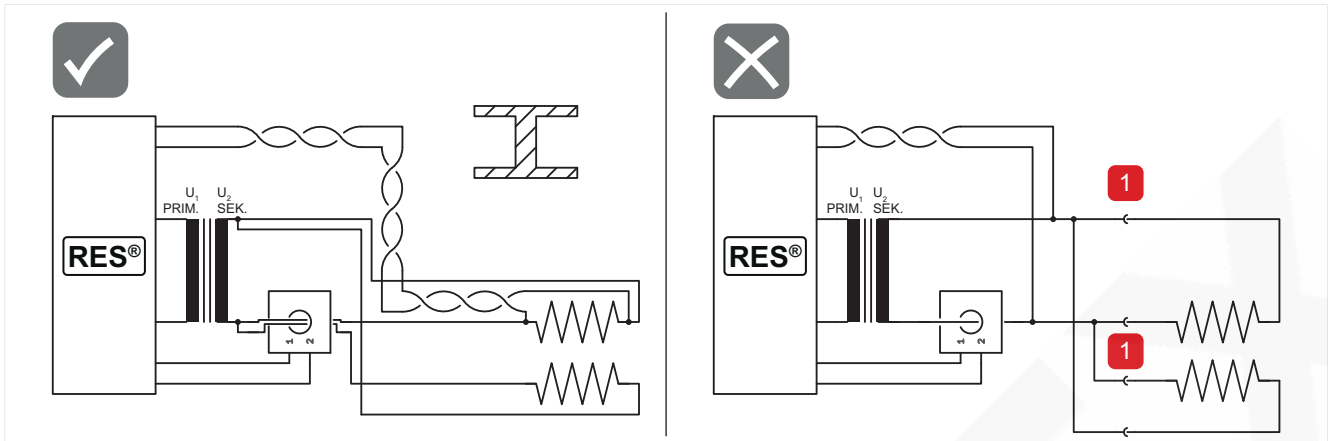

Illustration 22: Component wiring, example 6

Example 6 Using plug connectors (1) with parallel connection can negatively impact control accuracy.

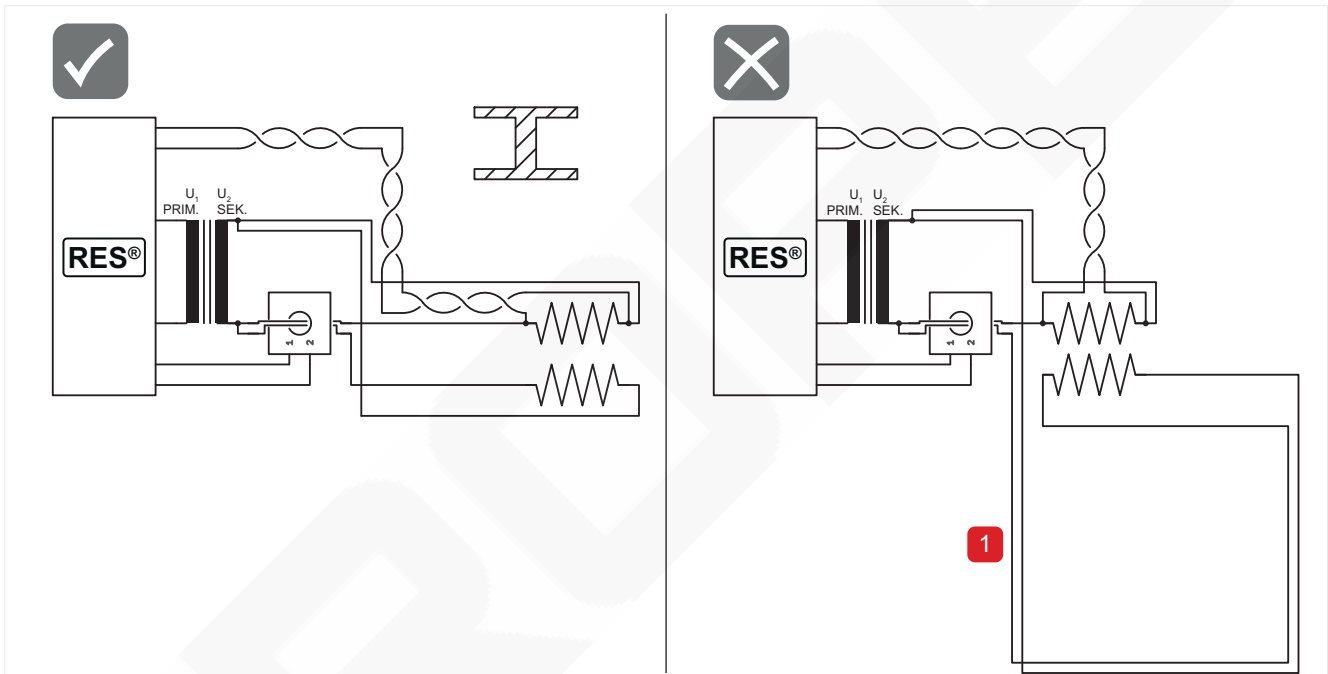

Illustration 23: Component wiring, example 7

Example 7 Significant differences in the length of the supply line (1) to the two heat-sealing bands negatively impact the accuracy of the temperature.

Series connection

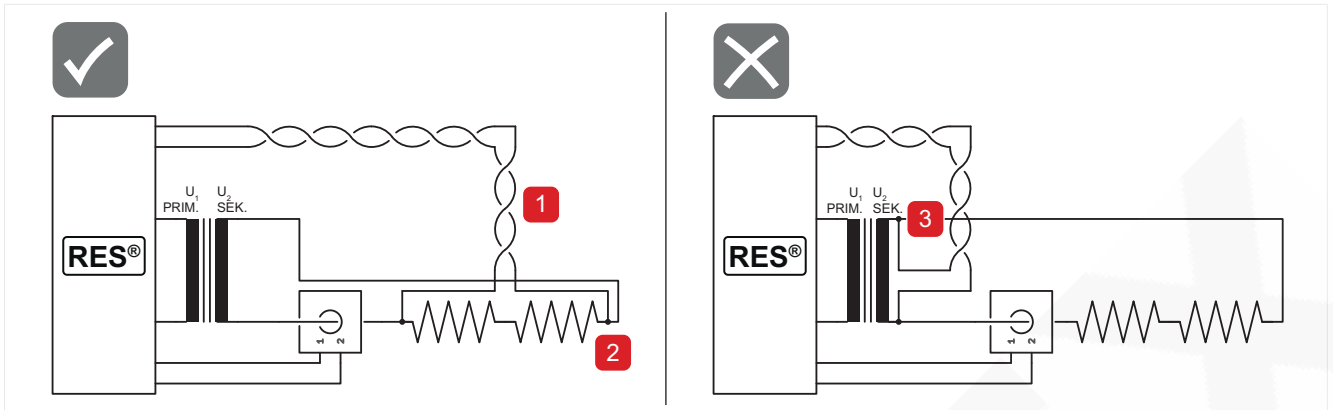

Illustration 24: Component wiring, example 8

Example 8 ▶ Connect the measurement cable (1) directly to the heat-sealing band (2)
 Background information: To prevent measurement errors caused by unintentionally measuring the line resistances, do not connect to the pulse transformer (3).

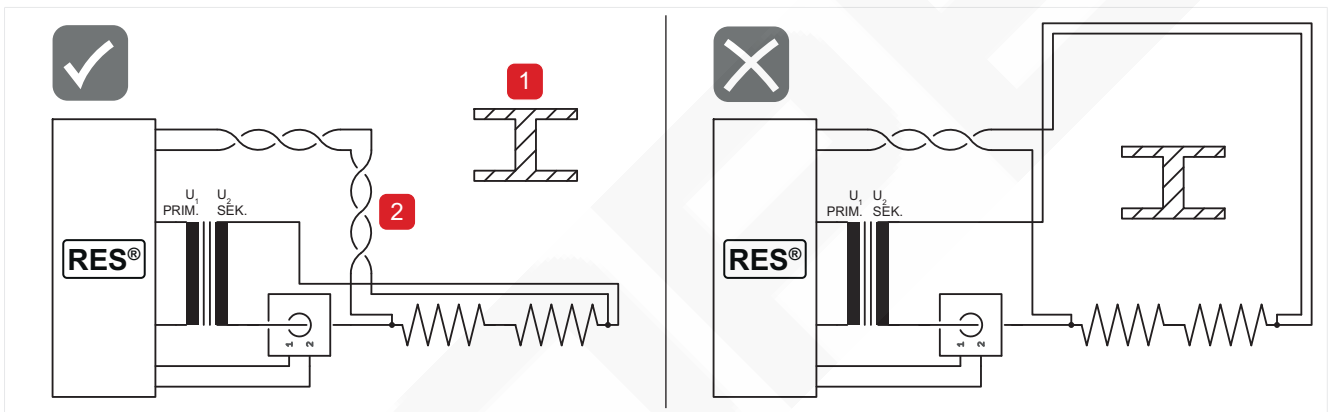

Illustration 25: Component wiring, example 9

Example 9 ▶ When objects have to be circumvented, especially iron or steel parts such as I-beams (1), lay the lines going in opposite directions on the same side whenever possible.
 ▶ Laying measuring cable (2) as twisted pair.

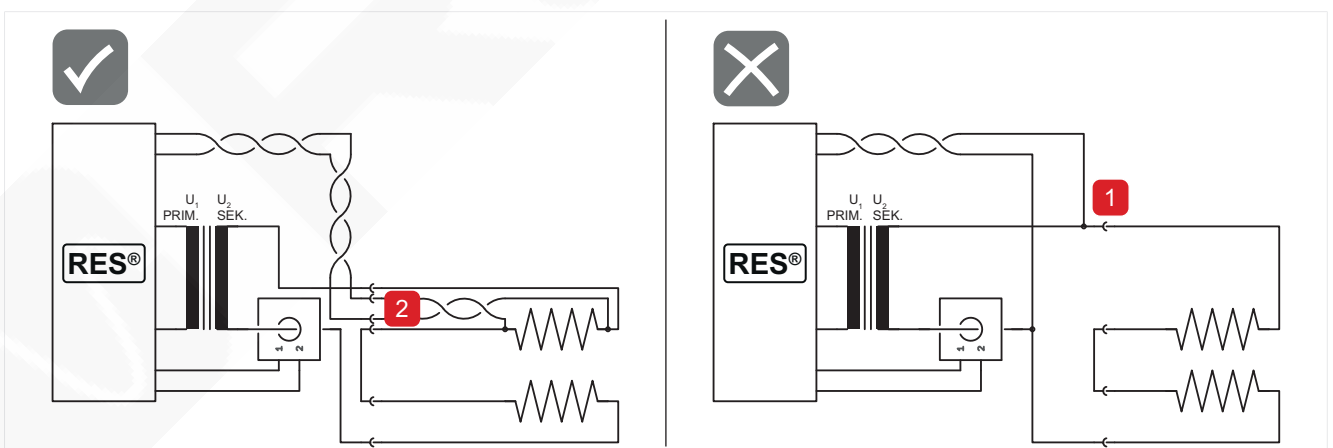

Illustration 26: Component wiring, example 10

Example 10 Installing plug connectors or clamping points (1) between the pulse transformer and the heat-sealing band can cause measurement errors.

- ▶ To prevent measurement errors caused by the contact resistances at the clamping points, use separate clamping points (2) to connect the measurement line to one of the two heat-sealing bands.

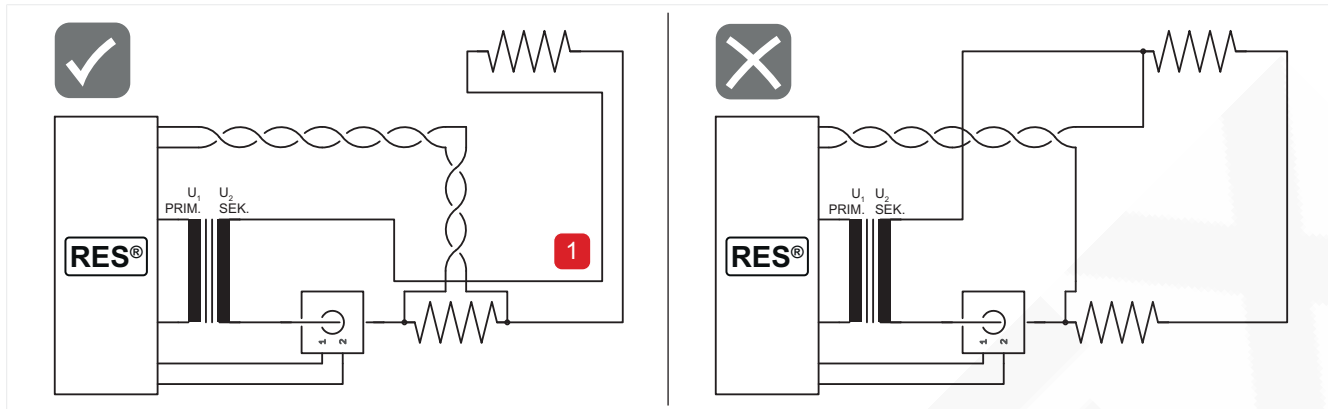

Illustration 27: Component wiring, example 11

- Example 11**
- ▶ If the heat-sealing bands switched in series are far apart from one another, lay the lines going in opposite directions (1) close together.
 - ▶ To prevent measurement errors caused by the resistance of the connecting line, connect the measuring line (1) directly to one of the two heat-sealing bands.

Index

A

AA bit	40
AC bit	40
Actual value input	64
Alarm relay	79
Alloy	
Coding dial	33
Altitude	79
Ambient conditions	79
Ambient temperature	79
Analog output	79
AUTOCAL	
active	40
Blocked	40
start	40
Automatic phase correction	52
Automatic zero calibration	40

B

B-075480\	
How to order	80
B-100400\	
How to order	80
B-100480\	
How to order	80
Booster connection	26, 27
Booster\	
How to order	80
Optional system component	20, 27

C

Calibration temperature	51
CBM-2\	
How to order	81
Certification	79
Channel selection	43
Clock	66
Coding dial	
Alloy	33
Temperature range	33
Connecting cable	79
Connection diagram	26, 27
Connection for external booster	26, 27
Constant regulation ratio	43
Contactors Kb	25
Current balance monitor\	
How to order	81
Current transformer\	
Essential system component	19
How to order	80

D

Data format	52
Date	66
Default	

Alarm relay	68
Alarm relay configuration	34
AUTOCOMP off	52
Coding dial position, temperature range and alloy	33
Heatup timeout off	55
Hold mode off	55
Limits for temperature diagnosis -10 K/+10 K	54
Temperature range and alloy	
Degree of protection	79
Device modification \ MOD	79

E

Error code format	52
Error codes	69
Error diagnosis	14
Essential system component\	
Current transformer	19
Line filters	20
Measurement cable	20
Pulse transformer	19

F

Fault area	73
------------	----

H

HCB-1	
How to order	81
HCB-2	
How to order	81
Heat-sealing band alloy	50
Heat-sealing band type	79
High-current rail	
How to order	81
Hold mode	55
Housing material	79
How to order	80
LF-30520	80
LF-50520	80
Pulse transformer	80
Transformer\	80
How to order\	

B-075480	80	MU = measurement interruption	39
B-100400	80		
B-100480	80		
Booster	80		
CBM-2	81		
Current balance monitor	81		
Current transformer	80		
HCB-1	81		
HCB-2	81		
High-current rail	81		
LF-06480	80		
LF-10520	80		
LF-20520	80		
Line filters	80		
Modification	80		
PEX-W5	80		
Temperature controller	80		
Humidity	79		
I			
Input data	39		
Interface	78		
K			
Kb	25		
KS (constant regulation) bit	43		
L			
LED	36		
LF-06480			
How to order	80		
LF-10520			
How to order	80		
LF-20520			
How to order	80		
LF-30520			
How to order	80		
LF-50520			
How to order	80		
Line filters\ Essential system component	20		
How to order	80		
Line frequency	78		
Line voltage	78		
M			
MA bit	42		
Master AUTOCAL	42		
Measurement cable\ Essential system component	20		
Measurement pause	42		
Measuring pulse duration	52		
Measuring range	78		
MOD\ Device modification	79		
Modification	79		
How to order	80		
MP bit	42		
O			
Optional system component\ Booster	20, 27		
P			
PEX-W5			
How to order	80		
Phase correction	52		
Power loss	79		
Power supply system	78		
Protection class	79		
Pulse transformer\ Essential system component	19		
How to order	80		
R			
RA bit	29, 31		
Replace heat-sealing band	75		
Reset	41		
ROPEXvisual®	65		
RS bit	42		
S			
Setpoint	44		
ST bit	29, 31, 41		
Standby mode	64		
Start	41		
Supply voltage	78		
System diagnostics	65		
System monitoring	68		
T			
TCR calculator	51		
Temperature coefficient	51		
Technical data	79		
Temperature control	14		
Temperature controller\ How to order	80		
Temperature diagnosis	54, 55		
High threshold	51		
Low threshold	51		
Temperature range	50, 79		
Coding dial	33		
Time	66		
Time stamp	66		
Transformer\ How to order	80		
Type of construction	78		
Type of flashing LED	36		
U			
UL	79		
Undervoltage detection	64		
USB interface	65		

По вопросам продаж и поддержки обращайтесь:

Алматы (727)345-47-04
Ангарск (3955)60-70-56
Архангельск (8182)63-90-72
Астрахань (8512)99-46-04
Барнаул (3852)73-04-60
Белгород (4722)40-23-64
Благовещенск (4162)22-76-07
Брянск (4832)59-03-52
Владивосток (423)249-28-31
Владикавказ (8672)28-90-48
Владимир (4922)49-43-18
Волгоград (844)278-03-48
Вологда (8172)26-41-59
Воронеж (473)204-51-73
Екатеринбург (343)384-55-89

Иваново (4932)77-34-06
Ижевск (3412)26-03-58
Иркутск (395)279-98-46
Казань (843)206-01-48
Калининград (4012)72-03-81
Калуга (4842)92-23-67
Кемерово (3842)65-04-62
Киров (8332)68-02-04
Коломна (4966)23-41-49
Кострома (4942)77-07-48
Краснодар (861)203-40-90
Красноярск (391)204-63-61
Курск (4712)77-13-04
Курган (3522)50-90-47
Липецк (4742)52-20-81

Магнитогорск (3519)55-03-13
Москва (495)268-04-70
Мурманск (8152)59-64-93
Набережные Челны (8552)20-53-41
Новокузнецк (3843)20-46-81
Ноябрьск (3496)41-32-12
Новосибирск (383)227-86-73
Омск (3812)21-46-40
Орел (4862)44-53-42
Оренбург (3532)37-68-04
Пенза (8412)22-31-16
Петрозаводск (8142)55-98-37
Псков (8112)59-10-37
Пермь (342)205-81-47

Ростов-на-Дону (863)308-18-15
Рязань (4912)46-61-64
Самара (846)206-03-16
Санкт-Петербург (812)309-46-40
Саратов (845)249-38-78
Севастополь (8692)22-31-93
Саранск (8342)22-96-24
Симферополь (3652)67-13-56
Смоленск (4812)29-41-54
Сочи (862)225-72-31
Ставрополь (8652)20-65-13
Сургут (3462)77-98-35
Сыктывкар (8212)25-95-17
Тамбов (4752)50-40-97
Тверь (4822)63-31-35

Тольятти (8482)63-91-07
Томск (3822)98-41-53
Тула (4872)33-79-87
Тюмень (3452)66-21-18
Ульяновск (8422)24-23-59
Улан-Удэ (3012)59-97-51
Уфа (347)229-48-12
Хабаровск (4212)92-98-04
Чебоксары (8352)28-53-07
Челябинск (351)202-03-61
Череповец (8202)49-02-64
Чита (3022)38-34-83
Якутск (4112)23-90-97
Ярославль (4852)69-52-93

Россия +7(495)268-04-70

Казахстан +(727)345-47-04

Беларусь +(375)257-127-884

Узбекистан +998(71)205-18-59

Киргизия +996(312)96-26-47

эл.почта: rxe@nt-rt.ru || сайт: <https://ropex.nt-rt.ru/>