

# Регулятор температуры RES-5009

## Инструкция по эксплуатации

По вопросам продаж и поддержки обращайтесь:

Алматы (727)345-47-04  
Ангарск (3955)60-70-56  
Архангельск (8182)63-90-72  
Астрахань (8512)99-46-04  
Барнаул (3852)73-04-60  
Белгород (4722)40-23-64  
Благовещенск (4162)22-76-07  
Брянск (4832)59-03-52  
Владивосток (423)249-28-31  
Владикавказ (8672)28-90-48  
Владимир (4922)49-43-18  
Волгоград (844)278-03-48  
Вологда (8172)26-41-59  
Воронеж (473)204-51-73  
Екатеринбург (343)384-55-89

Иваново (4932)77-34-06  
Ижевск (3412)26-03-58  
Иркутск (395)279-98-46  
Казань (843)206-01-48  
Калининград (4012)72-03-81  
Калуга (4842)92-23-67  
Кемерово (3842)65-04-62  
Киров (8332)68-02-04  
Коломна (4966)23-41-49  
Кострома (4942)77-07-48  
Краснодар (861)203-40-90  
Красноярск (391)204-63-61  
Курск (4712)77-13-04  
Курган (3522)50-90-47  
Липецк (4742)52-20-81

Магнитогорск (3519)55-03-13  
Москва (495)268-04-70  
Мурманск (8152)59-64-93  
Набережные Челны (8552)20-53-41  
Нижний Новгород (831)429-08-12  
Новокузнецк (3843)20-46-81  
Ноябрьск (3496)41-32-12  
Новосибирск (383)227-86-73  
Омск (3812)21-46-40  
Орел (4862)44-53-42  
Оренбург (3532)37-68-04  
Пенза (8412)22-31-16  
Петрозаводск (8142)55-98-37  
Псков (8112)59-10-37  
Пермь (342)205-81-47

Ростов-на-Дону (863)308-18-15  
Рязань (4912)46-61-64  
Самара (846)206-03-16  
Санкт-Петербург (812)309-46-40  
Саратов (845)249-38-78  
Севастополь (8692)22-31-93  
Саранск (8342)22-96-24  
Симферополь (3652)67-13-56  
Смоленск (4812)29-41-54  
Сочи (862)225-72-31  
Ставрополь (8652)20-65-13  
Сургут (3462)77-98-35  
Сыктывкар (8212)25-95-17  
Тамбов (4752)50-40-97  
Тверь (4822)63-31-35

Тольятти (8482)63-91-07  
Томск (3822)98-41-53  
Тула (4872)33-79-87  
Тюмень (3452)66-21-18  
Ульяновск (8422)24-23-59  
Улан-Удэ (3012)59-97-51  
Уфа (347)229-48-12  
Хабаровск (4212)92-98-04  
Чебоксары (8352)28-53-07  
Челябинск (351)202-03-61  
Череповец (8202)49-02-64  
Чита (3022)38-34-83  
Якутск (4112)23-90-97  
Ярославль (4852)69-52-93

Россия +7(495)268-04-70

Казахстан +(727)345-47-04

Беларусь +(375)257-127-884

Узбекистан +998(71)205-18-59

Киргизия +996(312)96-26-47

эл.почта: [gxe@nt-rt.ru](mailto:gxe@nt-rt.ru) || сайт: <https://ropex.nt-rt.ru/>

## RES-5009



### Important features

- CAN interface CAN 2.0A as per ISO 11898 for complete regulator control
- CANopen<sup>®1</sup> Protocol (as per CiA<sup>®1</sup> profile 301 in version 4.2.0)
- ROPEX CAN protocol
- Automatic zero calibration (AUTOCAL)
- Automatic optimisation (AUTOTUNE)
- Automatic configuration of the secondary voltage and current range (AUTORANGE)
- Automatic phase correction (AUTOCOMP)
- Automatic frequency adaptation
- Booster output standard
- Analogue output 0...10 VDC for ACTUAL temperature
- Additional 24 VDC control signals for START 0 (setpoint 0) and START 1 (setpoint 1)
- Alarm function with error diagnosis
- Heating element alloy and temperature range can be selected
- Wide voltage range for the use of 110...480 V
- Eight channels for administration of various calibration values
- Micro-USB interface for ROPEXvisual<sup>®</sup>
- cULus approval

## Contents

<b>1</b>	<b>Revision list</b>	<b>4</b>	<b>8</b>	<b>Startup and operation</b>	<b>21</b>
<b>2</b>	<b>General information</b>	<b>4</b>		8.1 Device view	21
2.1	Use of the operating instructions	4		8.2 Device configuration	21
2.2	Drawings and illustrations	4		8.3 Switch for activating the CAN terminating resistor	24
2.3	Copyright	4		8.4 Selection of CAN protocol	24
<b>3</b>	<b>Safety</b>	<b>5</b>		8.5 Burning in and changing the heating element	25
3.1	Warning notices in the operating instructions	5		8.6 Startup procedure	26
3.2	General safety information	6	<b>9</b>	<b>Device functions</b>	<b>29</b>
3.3	Intended Use	6		9.1 Display elements and operating elements	29
3.4	User qualifications	7		9.2 Input data	30
3.5	DECLARATION OF CONFORMITY	8		9.3 Output data	35
<b>4</b>	<b>Requirements for the functioning of the control system</b>	<b>9</b>		9.4 Parameter data	39
4.1	Heating element	9		9.5 Undervoltage detection	45
4.2	Impulse transformer	10		9.6 Temperature display (actual value output)	46
4.3	Current transformer	10		9.7 Booster connection	47
4.4	Line filter	10		9.8 USB interface for visualisation software ROPEXvisual®	47
4.5	Application report	10		9.9 AUX interface	48
<b>5</b>	<b>Product description</b>	<b>11</b>		9.10 Total cycles counter	48
5.1	Use	11		9.11 Operating hours counter	49
5.2	Functional principle	12		9.12 Data storage for error messages and AUTOCAL	49
5.3	Controller features	12		9.13 Integrated clock (date and time)	49
<b>6</b>	<b>Transport and Storage</b>	<b>13</b>		9.14 System monitoring/alarm output	50
6.1	Scope of Delivery	13		9.15 Error messages	51
6.2	Transport and Storage	13		9.16 Error ranges and causes	56
<b>7</b>	<b>Mounting and Installation</b>	<b>13</b>		9.17 Measures in the event of an error	57
7.1	Installation sequence	13			
7.2	Installation notes	15			
7.3	Mains connection	16			
7.4	Line filter	17			
7.5	Current transformer	17			
7.6	Wiring diagram (standard)	19			
7.7	Wiring diagram with booster connection	20			

<b>10</b>	<b>CANopen</b>	<b>58</b>	<b>11</b>	<b>ROPEX CAN</b>	<b>77</b>
10.1	Electronic Data Sheet (EDS)	58	11.1	Setting the baud rate	77
10.2	Setting the baud rate	58	11.2	Setting the CAN identifier	78
10.3	Setting the CANopen node address	60	11.3	ROPEX CAN LEDs	78
10.4	LSS	61	11.4	ROPEX CAN protocol	79
10.5	CANopen® LEDs	61	11.5	Receiving CAN messages	79
10.6	Heartbeat	62	11.6	Sending CAN messages	85
10.7	Object directory	63	11.7	Reading and setting the internal clock	91
10.8	PDO mapping	71	<b>12</b>	<b>Factory settings</b>	<b>91</b>
10.9	Emergency messages	72	<b>13</b>	<b>Maintenance</b>	<b>92</b>
10.10	Store and restore functionality	73	<b>14</b>	<b>Disposal</b>	<b>92</b>
10.11	START command	73	<b>15</b>	<b>Technical data</b>	<b>93</b>
10.12	Heating time limit	73	<b>16</b>	<b>Dimensions</b>	<b>95</b>
10.13	Master AUTOCAL (MA)	74	<b>17</b>	<b>Modifications (MODs)</b>	<b>96</b>
10.14	Temperature range and alloy	74	<b>18</b>	<b>How to order</b>	<b>97</b>
10.15	TCR calculator	74	<b>19</b>	<b>Index</b>	<b>99</b>
10.16	Signals START 0 and START 1	75			
10.17	Date and time in CANopen	75			
10.18	CANopen Time stamp object	76			
10.19	CANopen states	76			
10.20	Transmission of multi-byte elements with CANopen	76			
10.21	CANopen Timing values	76			

# 1 Revision list

Version	Modification
1	<ul style="list-style-type: none"> <li>Preparation of documentation</li> </ul>
2	<ul style="list-style-type: none"> <li>Addition: list „The AUTOCAL function is blocked.“ ↳ section 9.2.1 "AUTOCAL (AC) automatic zero calibration" on page 30</li> <li>Addition: note ↳ section 9.3.3 "Alarm active (AL)" on page 35</li> <li>Addition: function of Bit SA ↳ section 9.3.9 "Standby active (SA)" on page 37</li> <li>Addition: 24 V supply inrush current and control mode Distinction: supply inrush current and control mode ↳ section 15 "Technical data" on page 93</li> </ul>

## 2 General information

This RESISTRON<sup>®</sup> Temperature Controller has been developed and manufactured as per EN 61010-1 and is checked and monitored several times during manufacture as part of quality assurance. The device is leaving our factory in perfect condition.

### 2.1 Use of the operating instructions

These operating instructions are part of the product and describe the installation, start-up, operation, troubleshooting and maintenance of the RESISTRON<sup>®</sup> Temperature Controller.

Please read the operating instructions carefully before using the RESISTRON<sup>®</sup> Temperature Controller. Keep the operating instructions safe, for future reference. Please ensure that the important information and the functions are always available to the user in the vicinity of the RESISTRON<sup>®</sup> Temperature Controller.

In order to ensure safe operation, please observe the safety and warning information included in the operating instructions.

### 2.2 Drawings and illustrations

The drawings and illustrations in these operating instructions are exemplary. Many details are presented in a simplified manner.

### 2.3 Copyright

All contents, in particular texts, photographs and graphics, are protected by copyright. All rights, including to replication, publication, editing and translation, are reserved.



## 3 Safety

### 3.1 Warning notices in the operating instructions

These operating instructions contain warning notices if there is a risk of personal injury or property damage. The signal words in the warning notices draw attention to the particular dangers and indicate the severity of the danger. The warning notices contained in the operating instructions must be observed in order to ensure safe operation.

#### 3.1.1 Meaning of the signal words

The following signal words indicate the risk of personal injury and property damage:

Signal word	Importance
 <b>DANGER</b>	Imminent danger Consequence: Death or serious injuries
 <b>WARNING</b>	Possibly imminent danger Consequence: Death or serious injuries
 <b>CAUTION</b>	Possibly imminent danger Consequence: Slight or minor injuries
<b>ATTENTION</b>	Possibly imminent danger Consequence: Damage to property or environment

#### 3.1.2 Structure of section-related warnings

Section-related warnings apply to a section, a course of action or a specific procedure. They don't just apply to a specific act. The hazard symbols used indicate a general or specific hazard.

Section-related warnings are structured as follows:

Hazard symbol	SIGNAL WORD
	Type of danger and possible consequences Measures to avert the danger

#### 3.1.3 Structure of embedded warnings

Embedded warnings refer to a specific part within a paragraph. These warning notices apply to information units smaller than the section-related warning notices.

Embedded warnings are structured as follows:



#### SIGNAL WORD

Instructions to avoid a dangerous situation

### 3.1.4 Meaning of the hazard symbols

The hazard symbols in the warning notices have the following meanings:



Warning of a danger point or dangerous situation



Warning of electrical voltage

### 3.1.5 Information code

The following symbol indicates important information:



important information on the correct handling of the product

## 3.2 General safety information

	<b>⚠ WARNING</b>
	<p>Danger to life and danger of serious physical injuries as well as property damage if all warnings, regulations and information are not followed. Strictly follow all warnings, regulations and information in these operating instructions!</p>

	<b>⚠ WARNING</b>
	<p>Danger to life and risk of serious physical injuries as well as property damage if the work is not carried out in a professional and professional manner. Installation, electrical connection, start-up and maintenance of the RESISTRON® Temperature Controller may be carried out only by qualified, trained personnel in accordance with these operating instructions. Unauthorized and improperly carried out work during installation and reconstruction, electrical connection, start-up and maintenance is prohibited for safety reasons!</p>

## 3.3 Intended Use

RESISTRON® Temperature Controllers may be used only for heating and temperature control of heating elements that are expressly suitable for this purpose, in compliance with the regulations, notes and warnings listed in these instructions.

	<b>NOTE</b>
	<p>In case of non-compliance or improper use, there is a risk of impairment of safety or overheating of heating elements, electrical lines, transformers, etc. This is the user's own responsibility.</p>

### **3.4 User qualifications**

Only qualified specialists are allowed to carry out work such as assembly, installation, start-up and operation as well as troubleshooting and maintenance of the RESISTRON® Temperature Controller. Qualified specialists are persons who have been instructed in electrical engineering and who have the minimum qualifications required for their work. These persons are familiar with the dangers and the guarantee provisions and they have read and understood the operating instructions.

### 3.5 DECLARATION OF CONFORMITY

We hereby declare that the following device has been developed and manufactured in conformance with the directives cited below:

Designation: RESISTRON/CIRUS temperature controller with accessories  
Type: With line filter and current transformer  
Operating principle: Impulse sealing of films and plastics

#### Compliant with following standards and directives:

EN 61010-1	Safety requirements for electrical equipment, control, and laboratory use
2014/35/EU	Low voltage directive
2014/30/EU	Electromagnetic compatibility directive
2011/65/EU	RoHS directive

#### Note:

This declaration of conformity certifies that the device/electronic itself complies with the above-mentioned directives. The CE mark on the device/electronic does not relieve the machinery manufacturer of his duty to verify the conformity of the completely installed, wired and operationally ready system in the machine with the EMC directive.

#### Comments:

RESISTRON/CIRUS temperature controllers are not independently operable devices. They are used by the machinery manufacturer to form a sealing system by adding EMC-relevant components such as filters, transformers, heatsealing bands and wiring. The final configuration may vary significantly in terms of performance and physical dimensions. All information provided by us in connection with the line filter is merely intended as a guide and is based on a typical measuring setup. It serves to demonstrate that compliance with the EMC directive can be achieved by using a line filter that is suitable for the overall system. The line filter and current transformer must, however, be determined on the basis of the respective application. We also wish to point out that the transformer which is used must be designed in accordance with VDE 0551/EN 61558 or UL 5058 for safety reasons.

## 4 Requirements for the functioning of the control system

### 4.1 Heating element

The resistance of the heating element used must have a positive temperature coefficient for the proper functioning of the RESISTRON® Temperature Controller.

In order to achieve an optimal sealing result, the heating element and the type of connection must be adapted to the sealing application. The geometry of the heating element cannot be discussed here due to its diversity.

Accordingly, only some important physical and electrical characteristics are pointed out here:

The measurement principle used here requires a suitable temperature coefficient TCR from the heating element alloy. The RESISTRON® Temperature Controller is suitable for temperature coefficients in the range 400...4000 ppm/K.

As the heating element heats up, the resistance value increases, through which the control is made possible. If the temperature coefficient of the heating element is below the range, the control circuit oscillates or the heating element overheats.



#### NOTE

If the temperature coefficient of the heating element is greater than the set value, the real temperature is lower than the displayed temperature. However, if the temperature coefficient of the heating element is smaller than the set value, the real temperature is higher than the displayed temperature.

The temperature coefficient must be given as follows:

$$TCR = 10 \times 10^{-4} K^{-1} \text{ or } K^{-1} \text{ or ppm/K}$$

E.g. Alloy A20: TCR = 1100 ppm/K  
 Alloy L: TCR = 780 ppm/K  
 LEX3500: TCR = 3500 ppm/K  
 Vacodil: TCR = 1100 ppm/K

The setting or coding of the RESISTRON® Temperature Controller has to be carried out according to the temperature coefficient of the heating element used.

The temperature coefficient must be taken from the ROPEX application report and must be set accordingly.



#### WARNING

The use of the wrong alloys with a temperature coefficient, which is too low, or the wrong coding of the RESISTRON® Temperature Controller leads to uncontrolled heating and possibly to the burning up of the heating element!

More information:

- High-resistance heating elements, such as NiCr 80/20, are not suitable for an operation with a RESISTRON® Temperature Controller.
- **Parallel wiring:** In order to achieve a uniform temperature of both the heating elements, symmetrical cabling must be taken into account in case of parallel wiring of heating elements.
- **Series wiring:** When heating elements are connected in series, it must be ensured that the heating elements do not touch each other when they are heated on both sides. This would lead to an overcurrent and consequently to a selective increase in temperature.

- A very important design measure is copper-coating or silver-coating of the heating element ends. The thermal characteristics change in this range through coating of the heating element ends. As a result, the ends remain cold, which permits exact temperature control and increases the useful life of the heating element and the wear materials (e.g. silicone underlayment, heating band cover).

## 4.2 Impulse transformer

A suitable impulse transformer is required for the control loop to function properly. The power and the secondary voltage must be laid out for the control loop. According to EN 61558 or UL 5058, the transformer must be laid out as an isolating transformer with reinforced insulation and have a single-chamber structure. Adequate protection against accidental contact must be provided when assembling the impulse transformer. The relevant national installation and construction regulations must be observed, while doing so. Water, cleaning solutions and / or conductive liquids may not come into contact with the impulse transformer.

The cable cross-sections must be designed as per the ROPEX application report.

Incorrect assembly and installation of the impulse transformer impair electrical safety.

The terminals on the pulse transformer must be checked and tightened regularly.

## 4.3 Current transformer

The current transformer appropriate for RESISTRON<sup>®</sup> Temperature Controller is part of the control system.

In order to avoid malfunctions, only the original ROPEX current transformers or ROPEX monitoring current transformers may be used.

The current transformer may be operated only if it is correctly connected to the RESISTRON<sup>®</sup> Temperature Controller (See Chapter "Start-up"). The safety-related information in the "Mains connection" chapter must be observed. External monitoring modules can be used to increase operational safety furthermore. Monitoring modules are not part of the standard control system and are described in separate documentation.

## 4.4 Line filter

ROPEX offers line filters in various performance classes. The ROPEX Application Report lists the suitable line filter, which can be ordered.

For fulfilling the guidelines mentioned in the section 1.5 "DECLARATION OF CONFORMITY" on page 6, it has been stipulated to use an original ROPEX line filter. Installation and connection must be carried out in accordance with the instructions in the "Mains connection" chapter or the separate documentation for the respective line filter.

## 4.5 Application report

The ROPEX application report contains all the important technical information on your sealing applications. If you have several applications in a system, these are displayed in the application report on different pages and columns. This allows you to easily differentiate between them. The application report is created individually by the ROPEX application team and is the basis for the electro-technical design of your sealing applications.

The ROPEX application report contains the following information among other things:

- List of the different heating element dimensions
- Specification of the necessary temperature coefficient

- Electro-technical data as the basis for the electrical components
- Parts list and schematic diagram for the necessary components
- Instructions and recommendations for mechanical design
- Instructions for installing the cables and components

To receive a ROPEX application report, please fill out our completely. When you send the completed questionnaire, a new window opens with a reference number (e.g. AR1234) and a link to the questionnaire you created. This link enables you to reopen the questionnaire for your next inquiry. We therefore recommend that you save the link and the reference number.

Subsequently, you will have the opportunity to send us further information on this questionnaire, such as for example, technical descriptions or pictures.

The ROPEX application team then creates the application report based on the data you have entered. If relevant data is missing, we will contact you to clarify the open points. As soon as the application report has been created, you will receive it by email. We will then send you an offer for the components listed in the application report.

If you cannot judge whether your material can be sealed or what cycle rate is possible, we can also create sealing samples for you. We will then use our system and your material to check the possibility for sealing and incorporate the findings into the application report.

In this case you are welcome to contact Your request will then be passed on to the application team to coordinate the next steps.

## 5 Product description

### 5.1 Use

This RESISTRON<sup>®</sup> Temperature Controller RES-5009 is part of "Series 5000" with microprocessor technology as its main characteristic. All RESISTRON<sup>®</sup> Temperature Controller are used for controlling the temperature of heating elements. Heating elements are used in a wide variety of film sealing processes.

The most common heating elements include:

- ribbon cables (straight and contoured)
- tapered bands
- beaded bands
- cutting wires (straight and contoured)
- heated sealing and cutting knives
- soldering bows

The main application area is sealing or cutting of thermoplastics using the thermal impulse process.

The most common application areas are:

- vertical and horizontal flow wrapping machines (VFFS and HFFS)
- bagging, filling and sealing machines
- film-wrapping machines
- bag-production machines
- group packaging machines
- film welding devices
- spout and tube sealing
- and much more.

## 5.2 Functional principle

The resistance of the heating element, which changes with temperature, is measured by means of current and voltage measurement, displayed and compared with the specified setpoint value. Measurements are made 50 times per second in a 50 Hz line, 60 times per second in a 60 Hz line.

The primary voltage of the impulse transformer is adjusted following the leading edge principle if the measured values deviate from the setpoint value. The related current change in the heating element results in a rise in temperature and change of resistance. This change in resistance measured and evaluated by the RESISTRON® Temperature Controller RES-5009. The temperature controller adjusts the control variables according to the change and the established setpoint.

Even the smallest thermal loads on the heating element are recorded and can be quickly and precisely corrected. Measurement of pure electric variables, together with the high measurement rate, result in a highly dynamic thermoelectric control circuit. The principle of primary-side transformer control proves to be especially advantageous as it permits a very large secondary current range with low power loss. This permits an optimal adjustment to the load and thus the desired dynamics with extremely compact device measurements.

## 5.3 Controller features

The RESISTRON® Temperature Controller RES-5009 is equipped with a CAN interface. Through this CAN interface, all functions and parameters can be parameterised by means of the higher level machine controller. In addition, important controller information is queried and can be processed accordingly. CANopen and the ROPEX CAN protocol are supported.

The ACTUAL temperature of the heating element is output through the CAN interface and through an analogue output 0...10 VDC. The real heating element temperature can be visualised on an external display instrument (e. g. ATR-x) or via the operating unit of the machine controller.

The RESISTRON® Temperature Controller RES-5009 has an integrated error diagnosis, which checks both the external system (heating element, wiring, etc.) and the internal electronics. A differentiated error message is output through the CAN interface in case of a fault.

To increase operational security and immunity to interference, all CAN signals from the controller and heating circuit are electrically isolated.

Adjustment for different heating element alloys (alloy A20, Vacodil, etc.) and setting of the temperature range to be used (0...300 °C or 0...500 °C) can be made through coding switches on the temperature controller itself or through the CAN interface.

The compact design of the RESISTRON® Temperature Controller RES-5009 as well as the plug-in connecting terminals make mounting and installation easier.

An overview of the most important features and functions:

- AUTOCAL - Easy calibration of the heating element by automatic zero-point setting.
- Eight channels permit switching of the calibration parameters during tool change.
- AUTOTUNE - high control dynamics by automatic adaptation to the control path.
- AUTORANGE - automatic configuration of the secondary voltage range and current range, high flexibility due to the coverage of a secondary voltage range from 0.4 V to 120 V and a current range from 30 A to 500 A.
- Automatic adjustment to the line frequency in the range of 47 Hz to 63 Hz.
- Wide voltage range for flexible use from 110 VAC to 480 VAC
- Easy and convenient system diagnosis and process visualisation through the free, downloadable software ROPEXvisual®
- Comprehensive error diagnosis over the CAN interface
- Booster output available for connecting a switching amplifier

- High process security through comprehensive options for evaluating the parameter data (e. g. temperature diagnosis or heat-up time monitoring)

## 6 Transport and Storage

### 6.1 Scope of Delivery

After receipt of the delivery, immediately check the completeness of the scope of delivery on the basis of the accompanying documents.

After receipt of the delivery, perform a visual inspection for possible damage.

	<b>NOTE</b>
ROPEX Industrie-Elektronik GmbH does not assume any guarantee for defects that are subsequently claimed.	

### 6.2 Transport and Storage

Transport and store the device in its original box. For the ambient conditions, please refer to the technical data (↪ section 15 "Technical data" on page 93). After a longer period of storage of the RESISTRON® Temperature Controller RES-5009, ROPEX Industrie-Elektronik GmbH will handle the functionality testing for a fee.

## 7 Mounting and Installation

↪ See also section 4 "Requirements for the functioning of the control system" on page 9.

	<b>⚠ WARNING</b>
The assembly, installation and startup may be performed only by technically trained and competent persons. The persons must be familiar with the associated dangers and guarantee provisions.	

	<b>CAUTION</b>
The supply voltage to the machine side must lie within the permitted voltage and frequency range of the temperature controller. Otherwise, there is the danger of a defect.	

### 7.1 Installation sequence

Proceed as follows during mounting and installation of the RESISTRON® Temperature Controller RES-5009:

1. Switch off line voltage and 24 VDC power supply; verify lack of voltage.
2. Installation of the RESISTRON® Temperature Controller in the switching cabinet on a TS35 top-hat rail (in accordance with EN 60715). If several devices are mounted, the minimum distance specified in section 15 "Technical data" on page 93 must be maintained.

3. Wiring of the system in accordance with the regulations in section 7.3 "Mains connection" on page 16, section 7.6 "Wiring diagram (standard)" on page 19 and the ROPEX application report. The specifications in section 7.2 "Installation notes" on page 15 must also be observed.

Cables that are connected to control or measurement connections may only run within the building.

4. During installation, a circuit breaker with max. 10 A must be provided, e. g.:
  - circuit breaker in accordance with EN 60898 (characteristic B, C, D, K or Z)
  - circuit breaker in accordance with UL489 (\*) (characteristic B, C, D, K or Z)
  - protective fuse gG in accordance with IEC 60269
  - protective fuse "Class CC" or "Class J" in accordance with UL 248 (\*)

The circuit breakers marked with (\*) must be used in installations falling under the UL regulations.

If the specified circuit breaker is not sufficient for the welding application, two separate circuit breakers must be provided for the controller and the welding application (↪ ROPEX application report).

The circuit breaker must be located in the immediate vicinity of the device.

In the ROPEX application report, the smallest possible specification for this circuit breaker is specified based on the calculated currents. If the protective device is dimensioned differently, the current carrying capacity of the components used (e. g. cable, impulse transformer, etc.) must be adjusted accordingly.

5. A disconnect device must be provided during installation. The disconnect device must be properly marked as part of the system and attached in an easily accessible position.  
If a circuit breaker is used, it can take over the function of the disconnect device.
6. Connect the RESISTRON<sup>®</sup> Temperature Controller RES-5009 to the CAN network with a SUB-D9 connection cable according to specification CANopen CiA 303/1.

**CAUTION**

**Check all connection terminals of the system and the terminals for the coil wires on the impulse transformer – that they are seated firmly.**

7. Check the wiring in accordance with the applicable national and international installation and setup requirements.

7.2 Installation notes

	<b>NOTE</b>
<p>The correct dimensioning of the system components is crucial for the correct functioning of the control loop. Please take this data from the ROPEX application report.</p>	

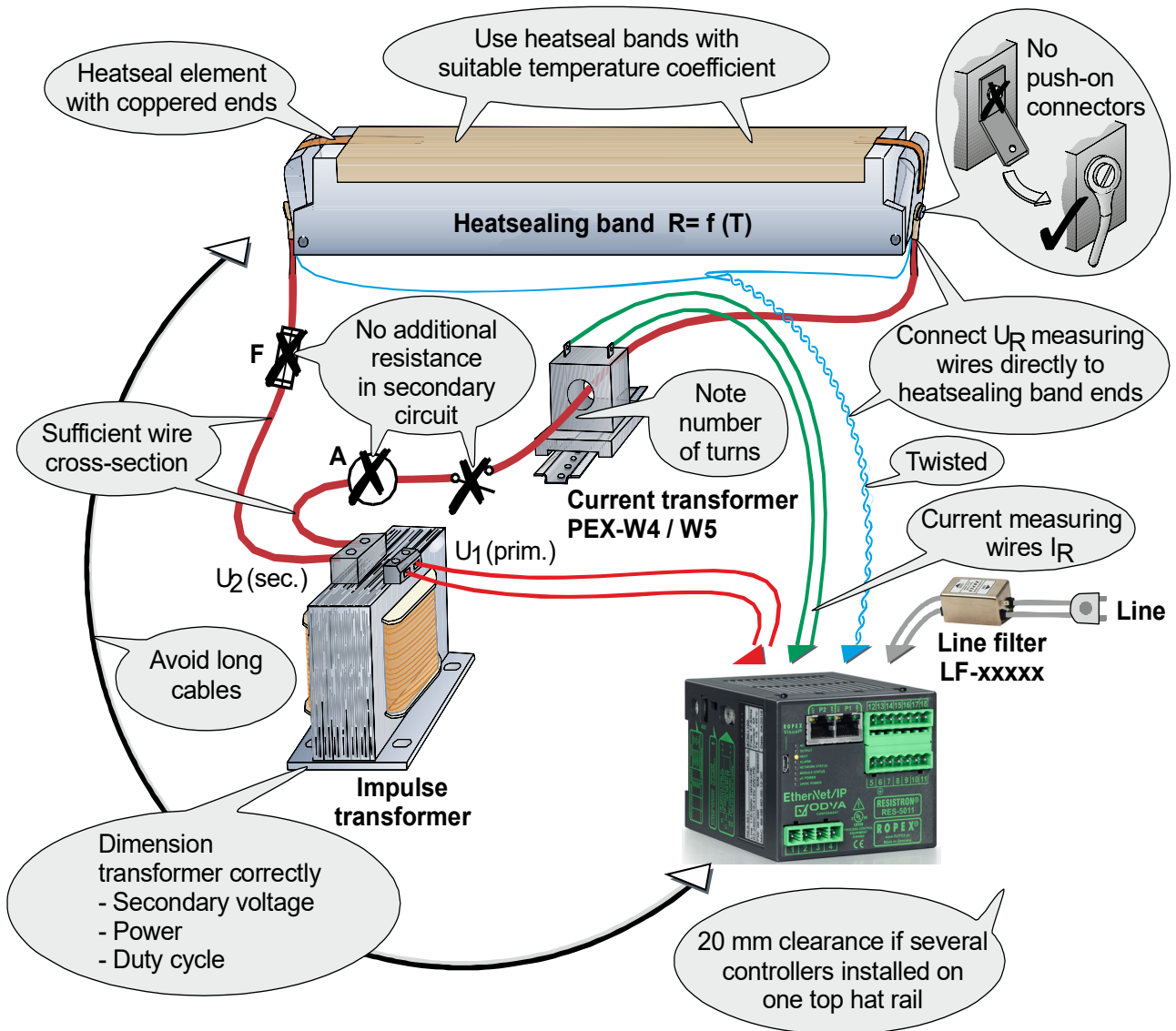

	<b>NOTE</b>
<p>In order to enable a good and stable control, additional resistances (fuses, long lines, plug connections, ...) must be avoided in the secondary circuit. Additional resistances influence the control and can make the system prone to errors, in the long term.</p>	

### 7.3 Mains connection

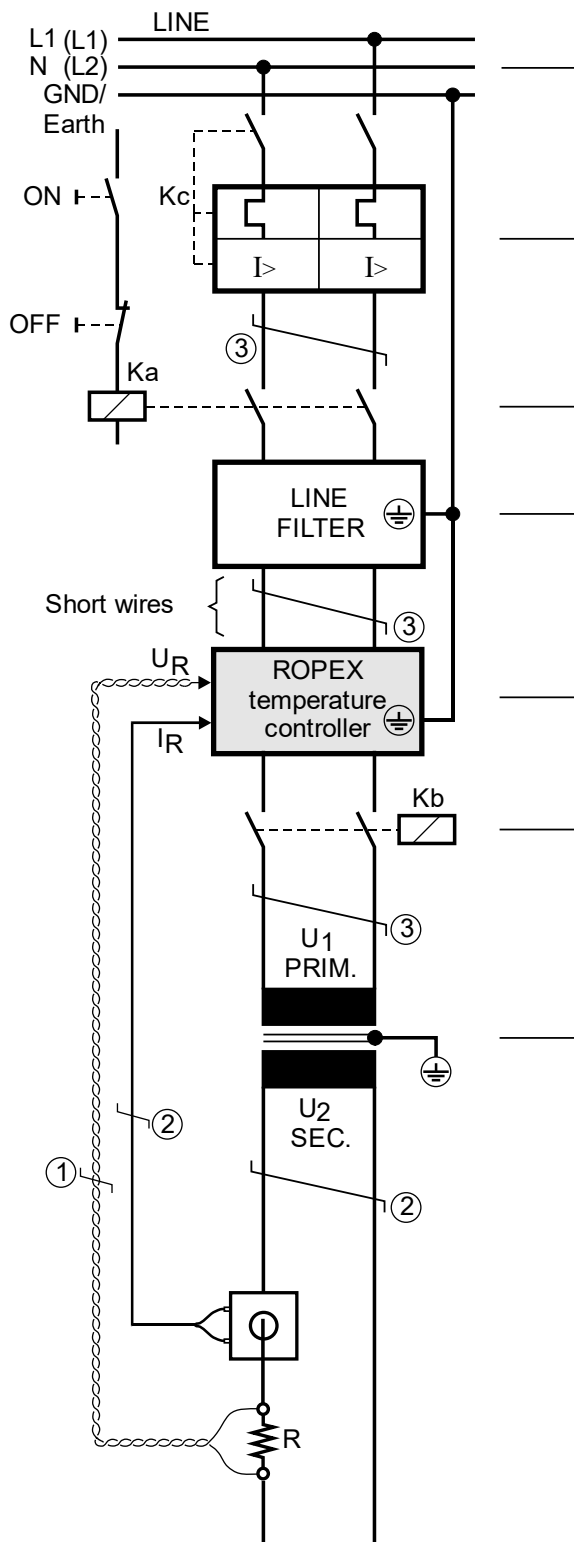

#### Line

To avoid disturbances while measuring, place several control loops on the same phase if possible.

#### Overcurrent device

2-Pole circuit breaker or fuses, (↪ ROPEX application report).



**ATTENTION - protection only in the event of a short circuit.**

**No protection of the RESISTRON® Temperature Controller.**

#### Contactor Ka

For all-pole disconnection, EMERGENCY OFF or EMERGENCY STOP.

Dimensioning ↪ ROPEX application report

#### Line filter

Filter type and filter size must be based on load, transformer and machine cabling (↪ ROPEX application report).



**CAUTION Do not lay filter supply lines (mains side) parallel to filter output lines (load side).**

#### RESISTRON® Temperature Controller

#### Contactor Kb



**CAUTION To increase machine safety by switching off the load on all poles in the event of a fault, e.g. in combination with the ALARM output of the RESISTRON® Temperature Controller.**

Dimensioning ↪ ROPEX application report  $I_{1max}$  (for Ka and Kb)

#### Impulsetransformer

Design according to EN 61558 or UL 5058 (isolating transformer with reinforced insulation). Ground core.



**CAUTION Use only single-chamber design. Power, ED number and voltage values must be determined individually depending on the application (↪ ROPEX application report).**

#### Wiring

Cable cross-sections depend on the application (↪ ROPEX application report).

- ① Make sure to twist (min. 20 beats/meter, ↪ Accessories “twisted measuring line”)
- ② Twisting (min. 20 beats/meter) necessary if several control loops are laid together (“Crosstalk”).
- ③ Twisting (min. 20 beats/meter) recommended to improve EMC properties.

## 7.4 Line filter

In order to comply with the EMC directive, RESISTRON control loops must be operated with earthed line filters. The earthed line filters serve to attenuate the effect of the phase-angle control on the line and to protect the controller against line disturbances.



### CAUTION

The use of a suitable line filter is part of compliance with the standards and a prerequisite for CE marking.

ROPEX line filters are specially optimized for use in RESISTRON control loops and guarantee compliance with the EMC limit values when installed and wired correctly. The specification of the line filter can be found in the ROPEX-application report created for your sealing application.

Further technical information: ↪ Documentation "line filter".

The supply of several control loops via a line filter is permitted if the total current does not exceed the maximum current of the filter.

The instructions in the section 7.3 "Mains connection" on page 16 with regard to cabling must be complied with. Example drawing for LF-06480:

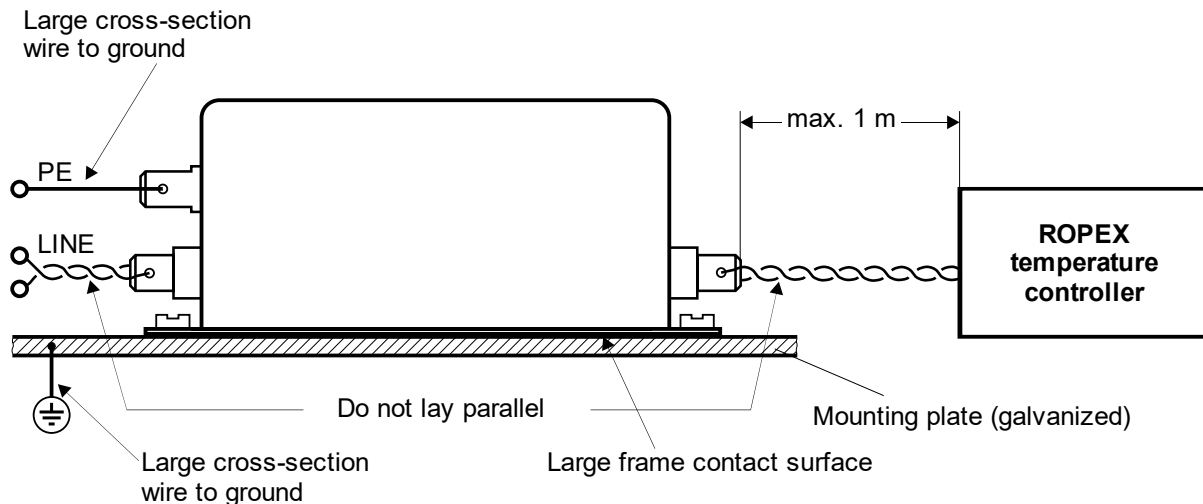

## 7.5 Current transformer

The current transformer PEX-W4/-W5 appropriate for RESISTRON<sup>®</sup> Temperature Controller is part of the control system. The current transformer may be operated only if it is correctly connected to the temperature controller (↪ section 7.3 "Mains connection" on page 16).

If several heating elements are operated with one control circuit, the installation can be found in the ROPEX application report. In special applications with RESISTRON<sup>®</sup> Temperature Controller it is necessary that a short circuit between the heating element and earth/housing is detected and the control system is switched off immediately. The MSW-2 monitoring current transformer can be used for this.

Further technical information can be found in the separate documentation for the current transformer and monitoring current transformer.

### 7.5.1 PEX-W4

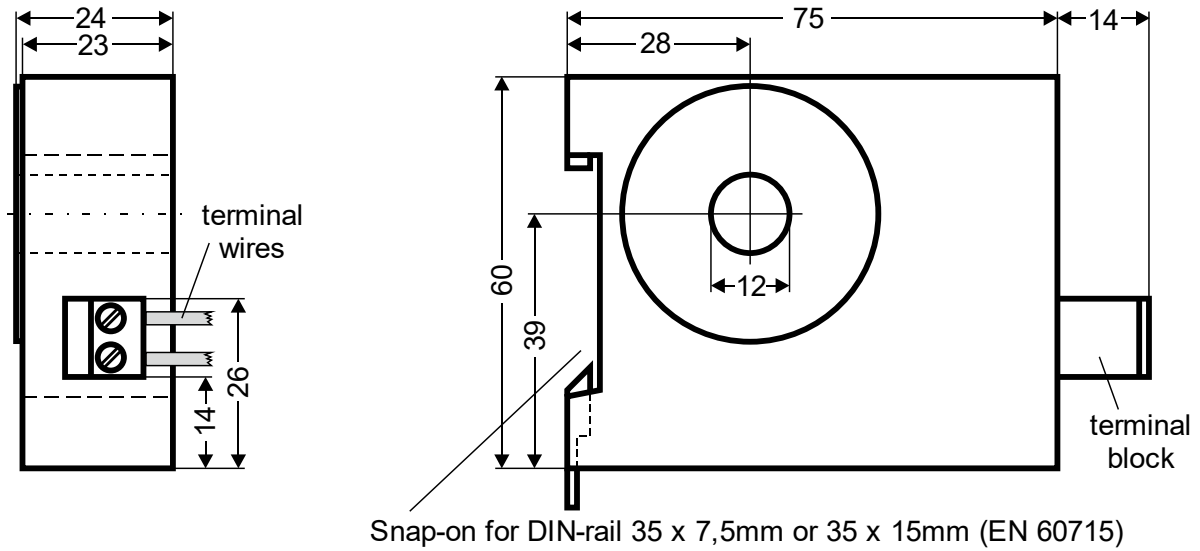

### 7.5.2 PEX-W5

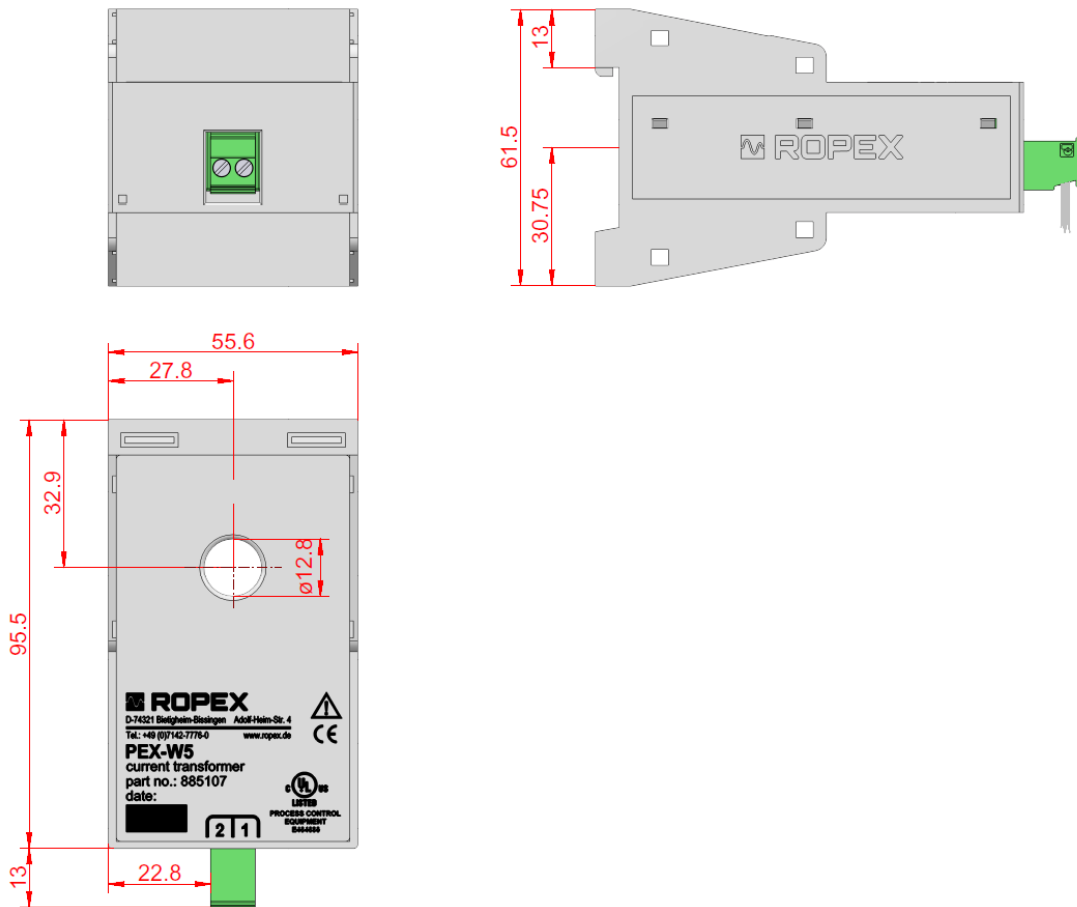

The current transformer is mounted on a hat rail measuring 35 x 7.5 mm or 35 x 15 mm in accordance with EN 60715.

If the high-current line cannot be conducted through the opening provided due to the diameter, an HCB-1 high-current rail must be used.

**7.6 Wiring diagram (standard)**

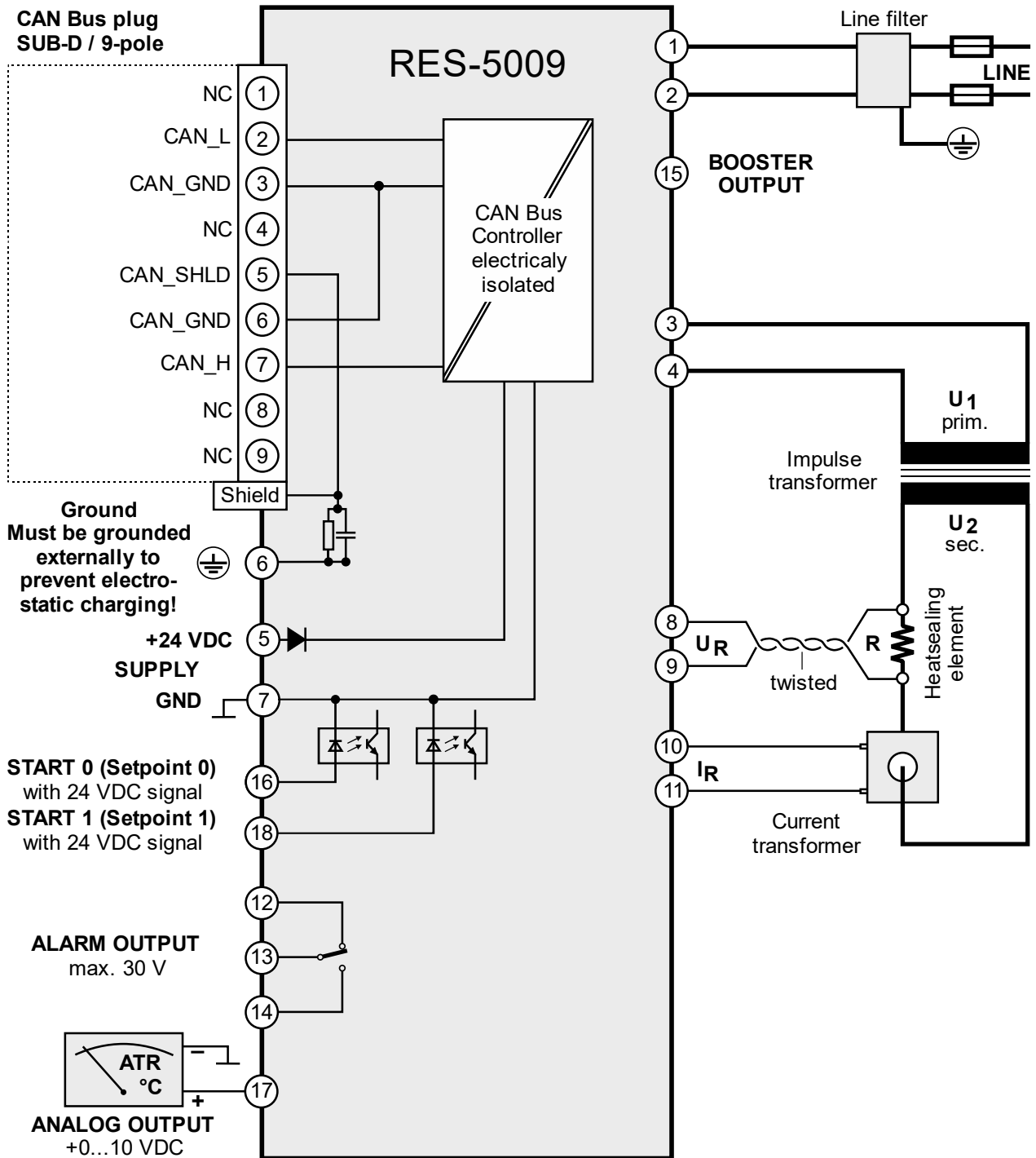



## 8 Startup and operation

### 8.1 Device view

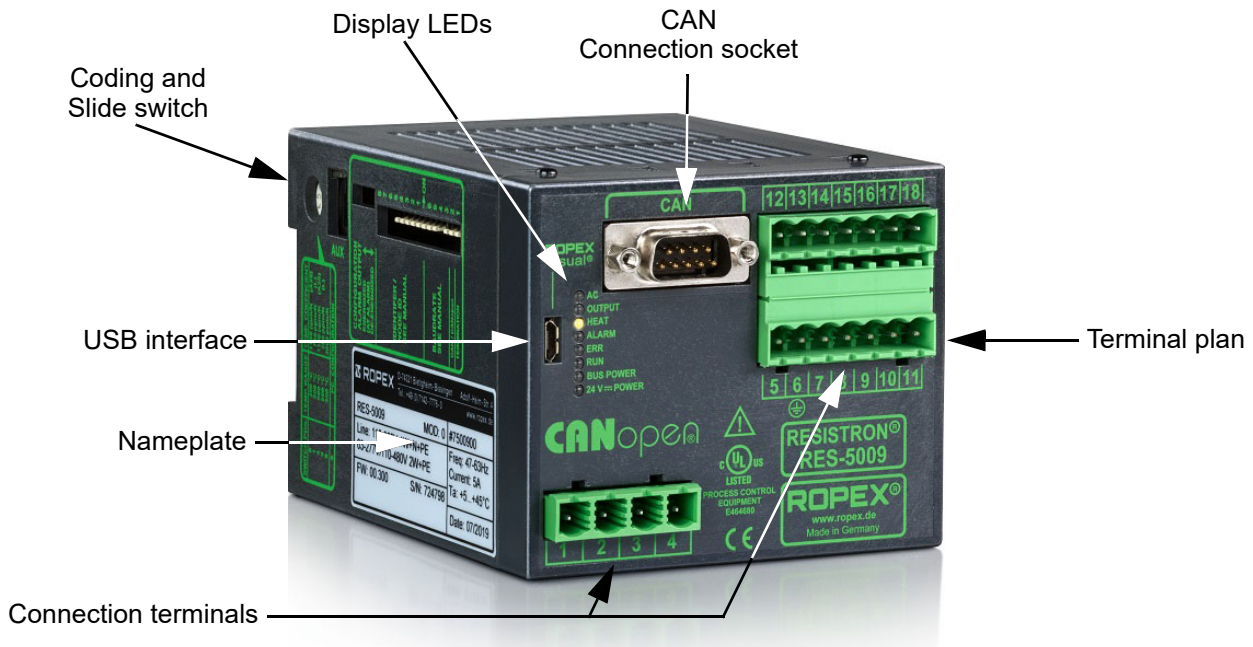

### 8.2 Device configuration

	<b>NOTE</b>
The controller must be switched off to configure the coding switch and the slide switch.	

#### 8.2.1 Configuration of the ranges for secondary voltage and current

The ranges for secondary voltage and current are configured automatically when automatic calibration (AUTOCAL) is carried out. Configuration takes place in the voltage range of 0.4 VAC up to 120 VAC and in the current range from 30 A to 500 A. If voltage and/or current is outside the allowed range, a detailed error message is output by the controller (↪ section 9.15 "Error messages" on page 51).

For secondary currents  $I_2$  less than 30 A, the secondary high-current line must be guided 2 times (or several times) through the transformer PEX-W4 or PEX-W5 (↪ ROPEX application report).



## 8.2.2 Configuration of the rotary coding switch for temperature range and alloy

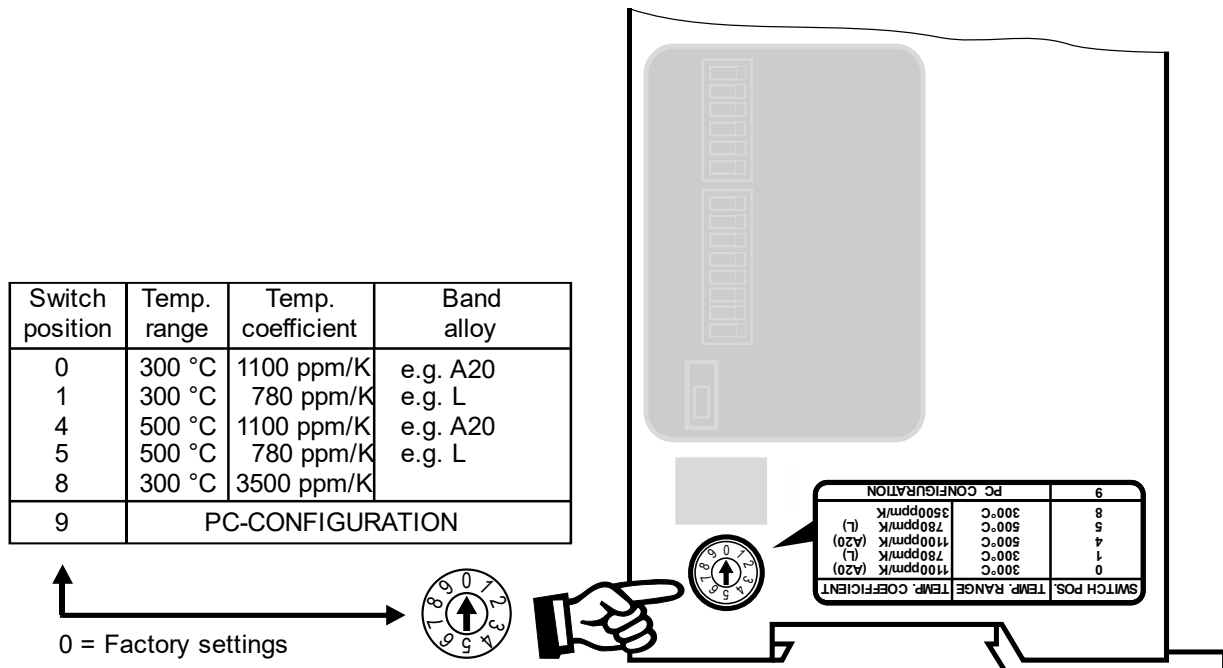

The setting of the rotary coding switch for temperature range and alloy can be overwritten by the parameter data (↪ section 9.4 "Parameter data" on page 39).

When the switch position "9" is selected, additional temperature ranges and alloys can be set through the ROPEX visualisation software (↪ section 9.8 "USB interface for visualisation software ROPEXvisual<sup>®</sup>" on page 47).

### 8.2.3 Configuration of the alarm relay

Alarm relay contact opened by alarm.

Alarm relay contact closed by alarm.  
(factory setting)

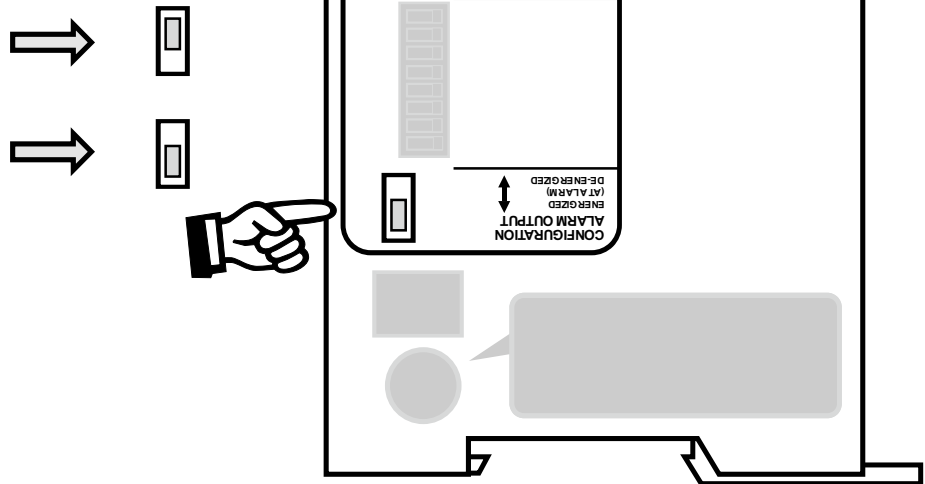

When the “Alarm relay contact opens with Alarm/PC CONFIGURATION” is selected, additional configurations for the behaviour of the alarm output can be set through the ROPEX visualisation software (see section 9.8 “USB interface for visualisation software ROPEXvisual®” on page 47).



#### NOTE

ROPEX recommends the configuration “Contact of alarm relay opens in case of alarm” in combination with contactor Kb to switch off the load in the event of a fault. As a result, the interruption of the line (cable breakage) between the alarm relay of the RESISTRON® temperature controller and the alarm signal relay will be monitored.

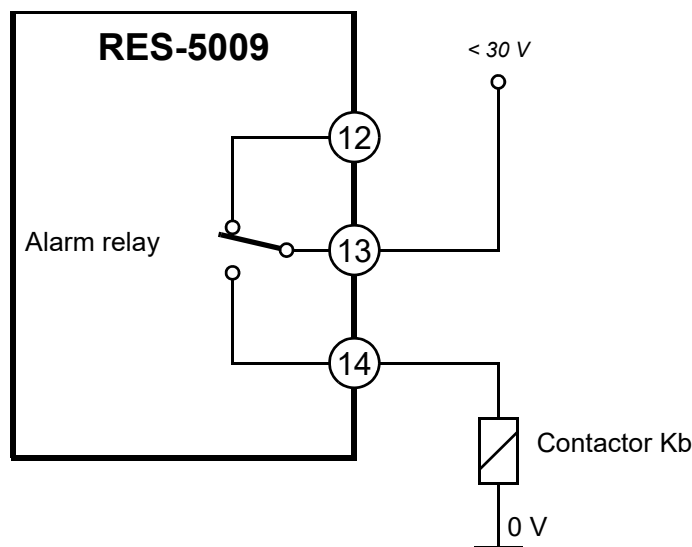

### 8.3 Switch for activating the CAN terminating resistor

With the DIP switch “TERMINATION”, a terminating resistor of 150 Ohm can be switched between the two CAN lines CAN-L and CAN-H. To activate the terminating resistor, the “TERMINATION” switch must be set to “ON”.

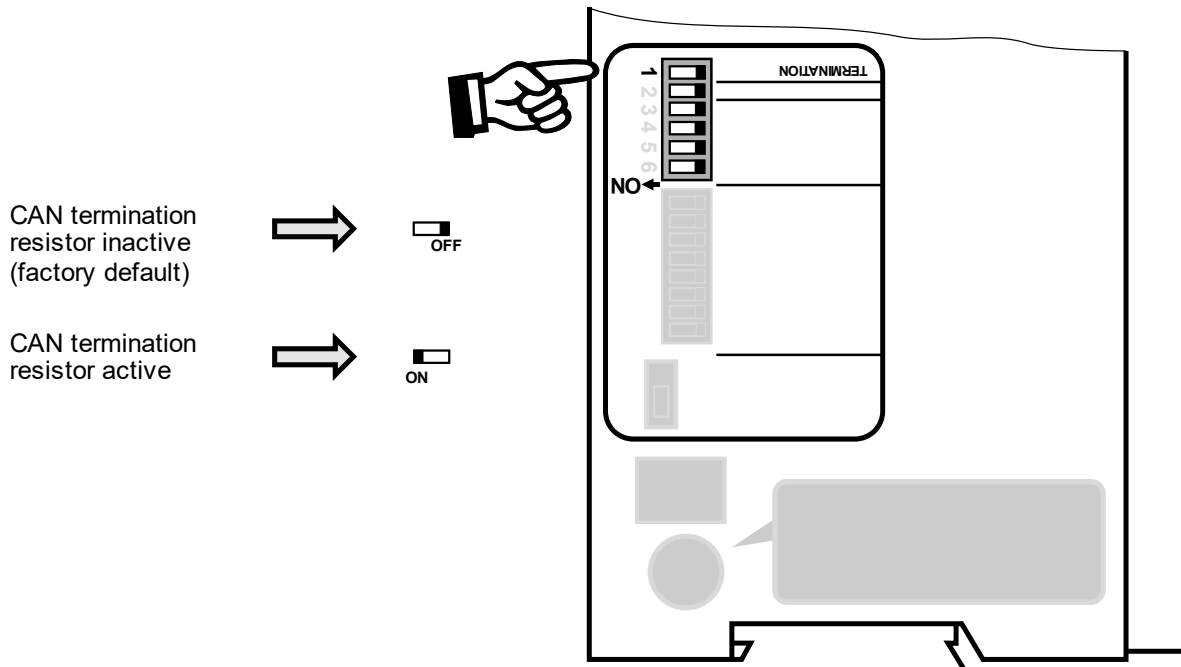

### 8.4 Selection of CAN protocol

The RESISTRON<sup>®</sup> Temperature Controller RES-5009 supports two different CAN protocols. The selection is made via the DIP switch “CAN / CANopen”.

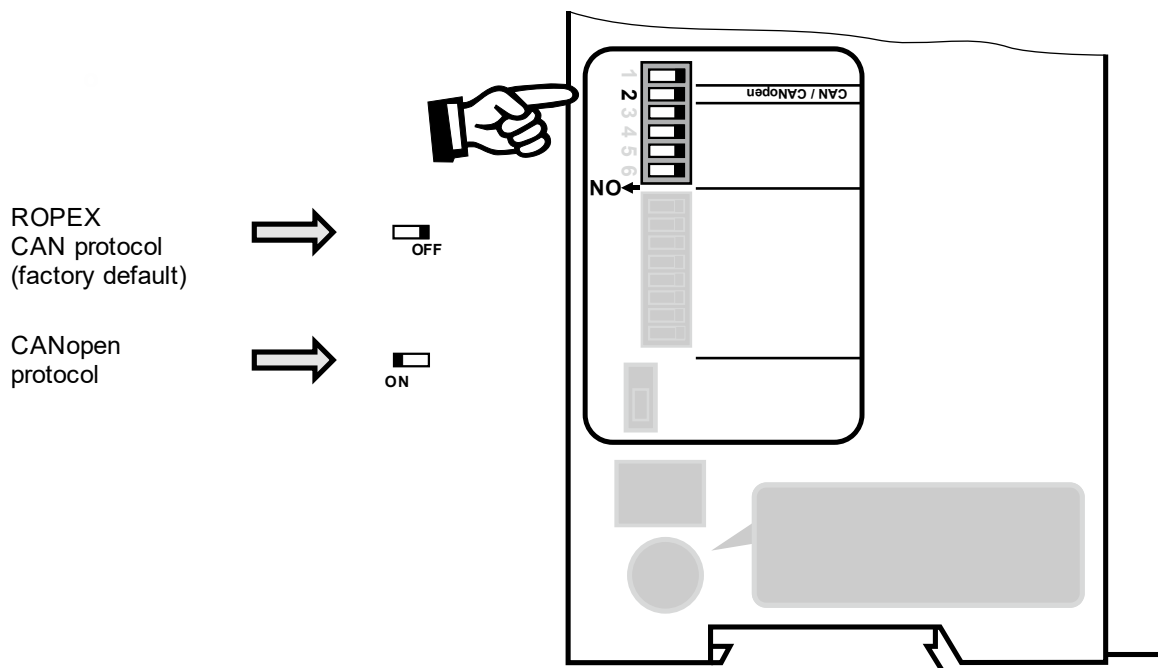

### Further information

- CANopen Protocol (as per CiA 301 profile in version: 4.2.0): ↪ section 10 "CANopen" on page 58
- ROPEX CAN protocol: ↪ section 11 "ROPEX CAN" on page 77

	<b>NOTE</b>
<p>The switch is evaluated once when the device is started. Switching during operation has no effect.</p>	

## 8.5 Burning in and changing the heating element

### 8.5.1 Burning in the heating element

The heating element is an important component in the control circuit, as it is both a heating element and sensor. Before using a heating element for the first time, please note the following.

#### Description of the burn-in effect:

When heating for the first time above 200 °C, some alloys (e. g. Alloy A20, Alloy L) experience a one-off change in the material properties (e. g. specific resistance).

The cold resistance of the heating element is reduced by about 2...3%. However, this small change in resistance generates a zero point error of 20... 30 K. Therefore, the zero point must be corrected after heating the first time, i. e., the AUTOCAL function must be carried out again. To do this, the system (heating element, underlayment, body, ...) must be cooled off completely.

After the first heating and renewed zero calibration (AUTOCAL), the heating element is burned in and the change of resistance is stabilised. The heating element can now be used.

#### Burn-in process:

It is carried out whilst the tool is open

1. Carry out AUTOCAL, so that the controller calibrates itself to the cold resistance of the heating element.
2. Heat the heating element to 250 °C, but at least 50 °C above the application-related sealing temperature.
3. Let the system (heating element, underlayment, body, ...) cool down completely until the heating element temperature is stable.
4. Carry out AUTOCAL again so that the new cold resistance can be measured.

The burn-in effect described here does not need to be considered if the manufacturer pre-treated the heating element for this purpose. The thermal pre-treatment is described as "burned in" at ROPEX in the article text

	<b>NOTE</b>
<p>If heating elements are used that have not been thermally pre-treated, the machine control (HMI) must enable the heating elements to be burned in.</p>	

	<b>⚠ WARNING</b>
<p>A damaged or burned out heating element may no longer be used due to irreversible changes in the material properties. This leads to a malfunction in the control.</p>	

## 8.5.2 Changing the heating element

	<b>NOTE</b>
	The heating element must be changed in accordance with the manufacturer's instructions.

	<b>⚠ WARNING</b>
	For changing the heating element, the supply voltage must be disconnected from the RESISTRON® Temperature Controller RES-5009 at all phases.

ROPEX recommends changing the heating element in case of:

- mechanical defects, bending or deformations
- scaled or oxidised heating element ends
- burned-in deposits
- damaged coatings, e. g. copper coating or Teflon-coating

After each change of the heating element, the zero calibration must be performed in case of a cold heating element and cold environment (i. e. Silicon, PTFE-cover, sealing bar, among others) with the function AUTOCAL, in order to compensate production-related tolerances of the heating element resistance.

When changing the heating element, we recommend that the underlayment is checked, e. g. Silicon profile with PTFE-fabric band. A damaged underlayment must be replaced to ensure that the heating element functions correctly.

If a new heating element is used, the above-described procedure for burning in must be performed.

If the new heating element has a different specification, it must be ensured that the voltage applied is adjusted to the resistance of the heating element. If the new heating element has another specification (e. g. heating element cross section, alloy), the application must be checked (↪ ROPEX application report). If this specification was not taken into account in the application report, the application report must be updated in accordance with the new requirements.

## 8.6 Startup procedure

Observe here section 2 "General information" on page 4 and section 5.1 "Use" on page 11.

	<b>⚠ WARNING</b>
	The assembly, installation and startup may be performed only by technically trained and competent persons. The persons must be familiar with the dangers associated with it and guarantee provisions.

### 8.6.1 Initial startup

Requirement: Device is correctly mounted and connected (↪ section 7 "Mounting and Installation" on page 13). Proceed as follows when starting up the RESISTRON® Temperature Controller RES-5009 for the first time:

1. Switch off line voltage and 24 VDC power supply; verify lack of voltage.
2. Selection of the CAN protocol: CANopen or ROPEX CAN  
(↪ section 8.4 "Selection of CAN protocol" on page 24)

3. Set the desired CANopen node address or CAN identifier  
(↪ section 10.3 "Setting the CANopen node address" on page 60 or ↪ section 11.2 "Setting the CAN identifier" on page 78).
4. In case of CANopen operation, integrate the EDS file into the CANopen master  
(↪ section 10.1 "Electronic Data Sheet (EDS)" on page 58).
5. Start higher-level control and ensure that no values other than zero are sent to the temperature controller.
6. Switch on the line voltage and 24 VDC power supply in any order.
7. After the voltage is switched on, the yellow "AUTOCAL" LED lights up for about 0.3 seconds and displays the correct switch-on process of the controller. As long as no line voltage is present, this LED blinks slowly (1 Hz).

	NOTE
<p>In addition to the yellow LED "AUTOCAL", if the red LED "ALARM" lights up for 0.3 seconds, after switching on, the configuration with the visualisation software has been changed for this controller (↪ section 9.8 "USB interface for visualisation software ROPEXvisual<sup>®</sup>" on page 47). The controller's configuration must be checked to avoid malfunctions before continuing with startup.</p>	

8. The following statuses can then result:

"ALARM" LED	"OUTPUT" LED	MEASURE
OFF	Short pulses every 1.2 seconds	Continue with item 9
BLINKS quickly (4 Hz)	OFF	Continue with item 9
Permanently ON	OFF	Error diagnosis (↪ chap. 9.15)

9. If the heating element is cold, activate the function AUTOCAL in the CANopen/CAN protocol (↪ section 9.2.1 "AUTOCAL (AC) automatic zero calibration" on page 30).  
The yellow "AUTOCAL" LED lights up for the duration of the calibration process approx. 10...15seconds. During the calibration process, the AA bit (**A**UTOCAL **a**ctive) is set and a voltage of 0 VDC is output on the actual value output (terminal 17+7). A connected temperature display ATR-x shows 0...3 °C.  
After zero calibration is completed, the "AUTOCAL" turns off and the AA bit is erased again. A voltage of 0.66 VDC (in 300 °C range and Autocal temperature = 20 °C) or 0.4 VDC (in 500 °C range) is reached at the actual value output. A connected temperature display ATR-x must be on the "Z" marking.  
If the zero calibration is not successful, the AL bit (**A**larm **a**ctive) is set and the red "ALARM" LED blinks slowly (1 Hz). Then the configuration of the controller is not correct (↪ section 8.2 "Device configuration" on page 21, ROPEX application report). After the device configuration is correct, perform the zero calibration again.
10. After successful zero calibration, specify a defined temperature over the CAN protocol (setpoint) and set the start request. The RA bit (**C**ontrol **a**ctive) is now active and the "HEAT" LED illuminated. The heat-up and control procedure can be observed at the actual value output:  
It is functioning correctly when the temperature (i. e. signal change at the analogue output or the actual value in the CAN protocol) is steady, that is, it does not jump, oscillate or even go briefly in the wrong direction. Such action indicates an incorrect placement of the U<sub>R</sub> measurement line.  
When an error message is issued, proceed according to section 9.15 "Error messages" on page 51.
11. Burning in the heating element (↪ section 8.5 "Burning in and changing the heating element" on page 25) and repeat AUTOCAL function.

## 8.6.2 Restarting after changing the heating element

While changing the heating element, proceed as per section 8.5 "Burning in and changing the heating element" on page 25.



### **WARNING**

Pay attention to correct alloys, dimensions and copper coating of the new heating element to avoid malfunctions and overheating.

Continue with chap. 8.6.1 item 5 to item 11.

## 9 Device functions

See also section 7.6 "Wiring diagram (standard)" on page 19.

### 9.1 Display elements and operating elements

<b>AC</b> (yellow LED)	Remains lit for duration of AUTOCAL process.
<b>OUTPUT</b> (green LED)	Indicates pulses in measurement mode. In control mode, luminous intensity is proportional to heating current.
<b>HEAT</b> (yellow LED)	Lit during heating phase.
<b>ALARM</b> (red LED)	Lights up or blinks to indicate ALARM.

<b>ERR</b> (red LED)	Lights up or blinks according to the CAN protocol used.
<b>RUN</b> (green LED)	Lights up or blinks according to the CAN protocol used.
<b>BUS POWER</b> (green LED)	Lit if internal power supply for CAN interface is OK.
<b>24 V =POWER</b> (green LED)	Lit if external 24 VDC power supply is present.

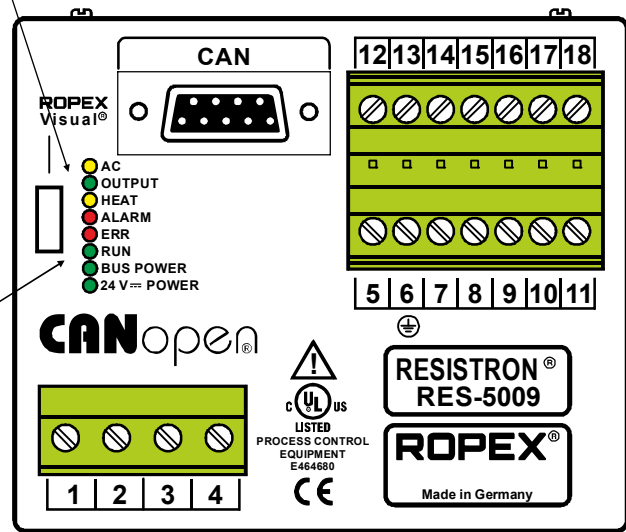

The LEDs display additional operating statuses of the controller besides the functions in the above illustration. These operating states are shown in detail in the following table:

LED	blinks slowly (1 Hz)	blinks quickly (4 Hz)	on permanently
<b>AC (AUTOCAL)</b> (yellow)	RS bit set (reset) or wait for line voltage	AUTOCAL requested, but function is blocked	AUTOCAL is carried out
	LED blinks with a different frequency: Incorrect (too low) supply voltage		
<b>OUTPUT</b> (green)	In control operation, the light intensity is proportional to the heating current.		
<b>HEAT</b> (yellow)	—	START requested, but function is blocked	START is carried out
<b>ALARM</b> (red)	Configuration error, AUTOCAL not possible	Controller incorrectly calibrated, carry out AUTOCAL	Error, ↪ chap. 9.15

## CAN communication

- **24 VDC voltage supply present:** RESISTRON<sup>®</sup> Temperature Controller RES-5009 can communicate via the CAN interface.
- **no line voltage present:** RESISTRON<sup>®</sup> Temperature Controller RES-5009 remains in an inactive state.
- **Interruption of the line voltage (e. g. by switching off when a door is opened):** triggers the error message 201 (error group no. 7, line voltage/sync signal is missing) and the Alarm relay switches. This is caused by the lack of line voltage. The error message can be deleted after the line voltage is switched on again by activating the reset (↪ section 9.2.3 "Reset (RS)" on page 32).  
The error message or switching of the Alarm relay – caused by switching off the line voltage – can be processed or suppressed in the PLC program without difficulty.

## 9.2 Input data

Input data are the data transmitted from the CANopen/CAN master to the RESISTRON<sup>®</sup> Temperature Controller RES-5009. They contain the setpoint and control functions, such as START or AUTOCAL for the RESISTRON<sup>®</sup> Temperature Controller RES-5009. The functions are explained in the following.

### 9.2.1 AUTOCAL (AC) automatic zero calibration

With the AUTOCAL function, the RESISTRON<sup>®</sup> Temperature Controller RES-5009 adapts to the current signals and voltage signals present in the system. The controller sets itself to the value predefined in the parameter data (↪ section 9.4.4 "Variable calibration temperature" on page 40). If no parameter data are transmitted from the CAN master, the standard value is 20 °C.



#### CAUTION

**In order to ensure that the seam quality remains constant, the set basic temperature for the calibration should correspond to the real ambient temperature.**

With some CANopen/CAN masters, the parameter data cannot be changed during operation. Adjustment of the calibration temperature to the current ambient conditions in the machine is therefore not possible.

The calibration temperature – with the appropriate setting in the parameter data (↪ section 9.4.4 "Variable calibration temperature" on page 40) – can therefore be specified at every zero calibration through the input data "Setpoint/AC temperature". This can be done in the range 0...+40 °C. The specified value for the calibration temperature must be entered in the input data "Setpoint/AC temperature" during activation of the AUTOCAL function (AC-Bit = 1). This specified value must remain entered until the end of the AUTOCAL function.

If too high of a temperature (greater than 40 °C) or a fluctuating specification value is specified, a corresponding error message is output (error no.115 and 116; ↪ section 9.15 "Error messages" on page 51).

The AUTOCAL request (AC-Bit = 1) is carried out by the controller if the AUTOCAL function is not blocked.

The automatic calibration process takes approx. 10...15 seconds, the related yellow LED on the front panel lights up and the controller reports "AUTOCAL active" (AA-Bit = 1) to the output data. Additional heating of the heating element does not take place here. The actual value output (terminal 17+7) goes to 0...3 °C (i. e. approx. 0 VDC). The AUTOCAL function is run through a maximum of 3 times, if the temperature of the heating element fluctuates. After that, if the function cannot be successfully ended, an error message is output (↪ section 9.15 "Error messages" on page 51).

The AUTOCAL function must be executed if the heating element has been changed or the wiring has been changed. In case the ambient temperature changes, there is no need to calibrate again.



#### CAUTION

**The AUTOCAL function must be enabled via the machine control (HMI). Otherwise, proper functioning cannot be guaranteed.**

**CAUTION**

Perform the AUTOCAL function only when the tool with the heating element has cooled off (basic temperature).

**The AUTOCAL function is blocked:**

- during the first 10 seconds if the controller does not report an alarm after being switched on or reset and the cooling speed is less than 0.1 K/s.
- if the cooling speed of the heating element is higher than 0.1 K/s.  
Note:  
If the AC bit is activated and the cooling speed has fallen below 0.1 K/s, the controller carries out the AUTOCAL function.
- if the START bit is activated (ST bit = 1).  
The "HEAT" LED lights up or blinks.
- if the RESET bit is activated (RS bit = 1).  
The "AUTOCAL" LED blinks slowly (1 Hz).
- if error numbers 101 to 103, 201 to 203 or 9xx occur directly after switching on the controller. (↪ section 9.15 "Error messages" on page 51).
- if the controller has operated correctly at least once after being switched on and error numbers 201 to 203 or 9xx occur (↪ section 9.15 "Error messages" on page 51).
- if the line voltage is missing when switching on.  
The "AUTOCAL" LED blinks slowly (1 Hz).

**Note:**

If the AUTOCAL function is blocked, the controller reports "AUTOCAL blocked" in the output data (AG bit = 1). If there is an AUTOCAL request in the input data at the same time (AC bit = 1), the "AUTOCAL" LED blinks quickly (4 Hz).

**Further information**

- CANopen: ↪ section 10.7.6 "Control information" on page 69 (AC bit)
- ROPEX CAN: ↪ section 11.5 "Receiving CAN messages" on page 79 (Address 0004<sub>h</sub> and value 5<sub>d</sub>)

## 9.2.2 Start (ST)

With the start request (ST bit), the device-internal target-actual comparison is enabled and the heating element is heated up to the set SETPOINT temperature. This takes place either until the start request (ST bit) is reset or until the optional heating time limit has expired. An abortion also occurs if the cyclic CAN communication does not take place.

The "HEAT" LED on the front panel of the RESISTRON<sup>®</sup> Temperature Controller RES-5009 lights up permanently during this heating time.

A start request is not processed,

- as long as the AUTOCAL function is active
- the controller is in the alarm state
- the setpoint is not higher than 40 °C or
- the reset (RS bit) is active.

In this case, the "HEAT" LED blinks.

Resetting the start request (ST bit) ends the heating process.

During a warning message with error no. 104...106, 111...114, 211, 302 or 303, the alarm relay is switched when start request (ST bit) is activated (↪ section 9.15 "Error messages" on page 51). A heat-up process also does not take place here.

### Further information

- CANopen: ↪ section 10.7.6 "Control information" on page 69 (ST bit)
- CANopen: ↪ section 10.11 "START command" on page 73
- CANopen: ↪ section 10.12 "Heating time limit" on page 73
- ROPEX CAN: ↪ section 11.5 "Receiving CAN messages" on page 79 (address 0005<sub>h</sub>)
- ROPEX CAN: ↪ section 11.5.2 "START/STOP command" on page 84

### 9.2.3 Reset (RS)

The reset request (RS bit) is used to reset the RESISTRON<sup>®</sup> Temperature Controller RES-5009 when the controller is in the alarm state.

As long as reset request (RS bit) is active, no AUTOCAL and no START request are accepted. In the error diagnosis, only errors no. 5 and 7 (201...203, 901, 913) are evaluated and output. In this status, no control of the power element takes place and no measurement impulses are generated. As a result, there is also no more updating of the actual value. The reset request is not processed until the RS bit is processed. The CAN communication is not interrupted by resetting of the controller.

During activation of the reset request (RS bits), the actual value output goes to 0...3 °C (i. e. approx. 0 VDC) and the SA bit is active. This can be evaluated as feedback by the higher-level controller (e. g. PLC).

The execution of the AUTOCAL function is not interrupted by activation of the reset request (RS bit).

After resetting the reset request (RS bit), the controller carries out an internal initialisation for about 500 ms. The next welding procedure can only be started after that.



#### NOTE

If a contactor Kb is used to switch off the control loop (↪ section 7.3 "Mains connection" on page 16), it must be switched on safely no later than 200 ms after the reset request (RS bit) has been reset. The switching and delay times of the contactor must be observed. Switching on later results in an alarm message from the controller.

### Further information

- CANopen: ↪ section 10.7.6 "Control information" on page 69 (RS bit)
- ROPEX CAN: ↪ section 11.5 "Receiving CAN messages" on page 79 (address 0004<sub>h</sub>, value 6<sub>d</sub>)

### 9.2.4 Measurement pause (MP)

By activating the measurement pause (MP bit), the RESISTRON<sup>®</sup> Temperature Controller RES-5009 immediately generates no measuring pulses any more. In the error diagnosis, only errors no. 5 and 7 (201...203, 901, 913) are evaluated and output. The actual value is no longer updated. The most recent value – valid before activation of the measurement pause (MP bit) – is output. After deactivating the measurement pause, measuring pulses are immediately generated again, all error messages are evaluated and the actual value is updated.

The measurement pause request (MP bit) is effective only in measurement mode. Start, reset and AUTOCAL request have priority.

The measurement pause request (MP bit) is suitable for applications in which the electrical connections of the heating element must be disconnected during normal operation without an alarm being triggered (e. g. with sliding rail contacts).

In contrast to the reset request (RS bit), the measurement pause request (MP bit) does not delete any alarm messages. After deactivating the measurement pause (MP bit), the controller is immediately active again, no initialisation phase is run through.

After switching on the controller, the measurement pause request is only evaluated by the controller when the system check (incl. function check of the heating circuit) has been successfully completed. This can take several 100 ms.

#### Further information

- CANopen: ↪ section 10.7.6 "Control information" on page 69 (MP Bit)
- ROPEX CAN: ↪ section 11.5 "Receiving CAN messages" on page 79 (address 0050<sub>n</sub>)

### 9.2.5 Channel selection (CH0...CH2)

The RESISTRON<sup>®</sup> Temperature Controller RES-5009 has separate memories for up to eight calibration data sets. A calibration data set contains the values that the temperature controller determines during the AUTOCAL function. Saving of the calibration data sets allows to operate welding tools in alternation without having to perform the AUTOCAL function after each change. AUTOCAL has to be performed only when connecting a new heating element.

As different calibration values, Autocal temperatures and temperature coefficients are available for this in the controller, the desired calibration data set 0...7 can be selected over the 3 bits CH0...CH2. The channel can be switched at any time.

This function can be used, for example, in applications that require frequent change of the format. In such a case, different tools can be replaced for the different formats. A channel that contains the corresponding calibration data set can be assigned to each tool. When all tools have been calibrated with a uniquely assigned channel, the following changes can be performed by just selecting the corresponding channel again.

For applications that do not require a format change, the channel can stay at 0. As a result, the temperature controller acts exactly like older models that do not yet support any different calibration data sets.

While the channel can be switched during performance of the AUTOCAL function, the controller works with the channel chosen at the start of the AUTOCAL function until the AUTOCAL function is completed. The channel currently used by the controller is visible in the status information.

The selected channel is not stored retentively in the temperature controller. After restarting the device, the desired channel must be set again. Channel 0 is active by default.

### 9.2.6 Setpoint

Depending on the selected temperature range (↪ section 9.4.1 "Temperature range and alloy" on page 39), the setpoint can be specified up to 300 °C or up to 500 °C. In case of larger setpoints, write access (CANopen) is rejected, or the internal limit is set to 300 °C or 500 °C (ROPEX-CAN).

### 9.2.7 24 VDC control signal

The activation of a START/STOP command for setpoints 0 and 1 can also be carried out via a digital 24 VDC control signal (START 0 or START 1). With activation of a START signal, the device-internal target-actual comparison is enabled and the heating element is heated up to the set SETPOINT temperature. This takes place until the signal is switched off.

The "HEAT" LED on the front panel of the RESISTRON<sup>®</sup> Temperature Controller RES-5009 lights up permanently during this time.

The "START" signal (START 0) for setpoint 0 is activated via a 24 VDC signal at terminals 16+7.

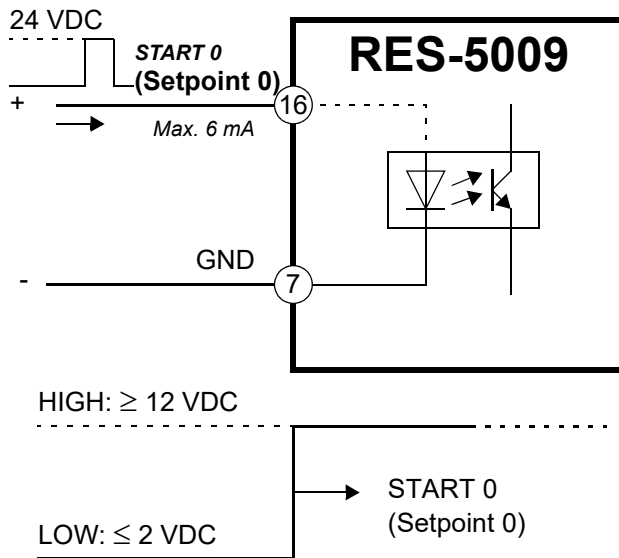

The "START" signal (START 1) for setpoint 1 is activated via a 24 VDC signal at terminals 18+7.

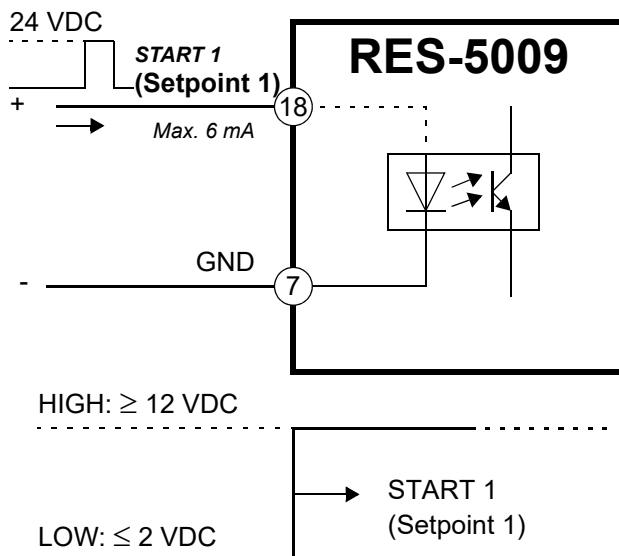

The setpoint specification for the welding temperature must be greater than 40 °C. If the setpoint specification is smaller, the heat-up process is not started (LED "HEAT" blinks).

During a warning message with error no. 8...12 or 104...106, 111...114, 211, 302, 303, the alarm output is switched when a START command (or the START signal) is activated (↪ section 9.15 "Error messages" on page 51). A heat-up process also does not take place here.



#### CAUTION

The 24 VDC signal START 0 has the highest priority and overwrites the specifications of the 24 VDC signal START 1 as well as the START commands via the CAN interface.

The 24 VDC signal START 1 has the lowest priority. All START commands via the CAN interface as well as the 24 VDC signal START 0 have a higher priority

### 9.3 Output data

Output data are the data transmitted from the RESISTRON<sup>®</sup> Temperature Controller RES-5009 to the CANopen/CAN master. The output data contain the current actual value and all important information about the current status of the controller. In case of alarm, an exact error diagnosis can be performed using the error number.

#### 9.3.1 AUTOCAL active (AA)

The AA bit shows that the AUTOCAL function is currently being executed.

#### 9.3.2 AUTOCAL blocked (AG)

If the AG bit is set, the AUTOCAL function is currently blocked. That is the case when START is active or the heating element is still in the cooling off phase.

#### 9.3.3 Alarm active (AL)

If the AL bit is set, an alarm was triggered and not reset yet. The error number provides information about the exact cause of the error (↪ section 9.15 "Error messages" on page 51).

Note:

In order to determine whether the temperature controller is ready for the sealing process, the alarm active (AL) **and** standby active (SA) bits must be queried. If both bits are set to "0", all prerequisites are fulfilled and the sealing process is possible (↪ section 9.3.9 "Standby active (SA)" on page 37).

#### 9.3.4 Warning active (WA)

The WA bit can be set in addition to the AL bit. If the WA bit is set, the current alarm is a warning. In this case, the alarm relay is not active.

#### 9.3.5 Temperature reached (TE)

The TE bit is set when the actual temperature has reached 95% of the setpoint temperature. As soon as the control mode is ended (Start request = 0) or an alarm occurs (AL bit = 1), this status bit will be reset again.

#### 9.3.6 Temperature OK (TO)

The RESISTRON<sup>®</sup> Temperature Controller RES-5009 checks whether the actual temperature lies within a settable "good window" tolerance band around the setpoint temperature. The lower ( $\Delta\vartheta_{unten}$ ) and upper ( $\Delta\vartheta_{oben}$ ) tolerance band limit can be changed separately through the parameter data (↪ section 9.4 "Parameter data" on page 39). The following settings are possible:

1. "Off"

The TO bit is always reset.

2. "active when Tact = Tset" (factory setting)

The TO bit is set when the actual temperature is within the set temperature monitoring band. If the actual temperature is outside the monitoring band, the TO bit is reset (see following graphic).

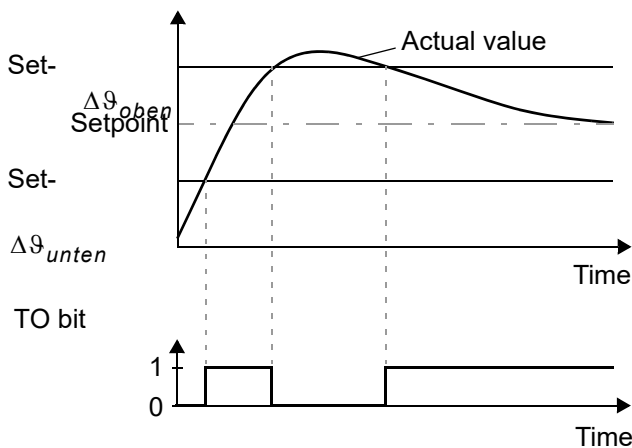

The actual temperature is hereby evaluated independently of the control mode, in contrast to the “Temperature reached” (TE bit) status bit.

### 3. “Active when Tact = Tset”, with latch function

A welding cycle begins with setting the start request (ST bit).

The TO bit is set if the actual temperature reaches the temperature monitoring band for the first time within a welding cycle. If the start request is still active and the monitoring band is left again, the TO bit will be reset (see Image a.). If the start request is still active and the actual temperature no longer leaves the monitoring band, the TO bit will not be reset until the start of the next welding cycle (latch function, see Image b.). The switching status of the TO bit can thus be queried after resetting of the ST bit and before the start of the next welding cycle.

a.) Temperature *not* OK

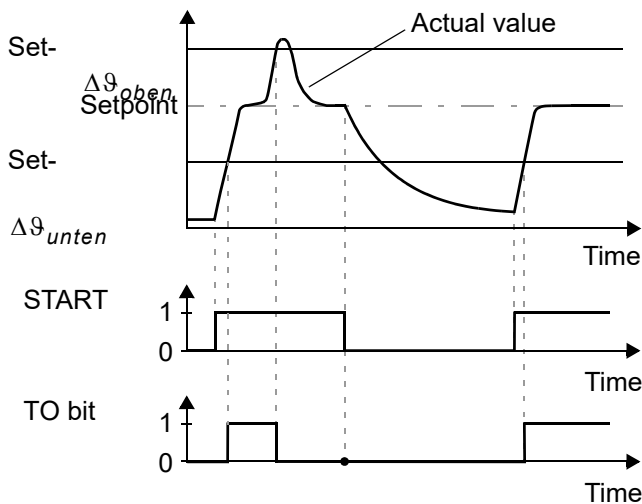

b.) Temperature OK

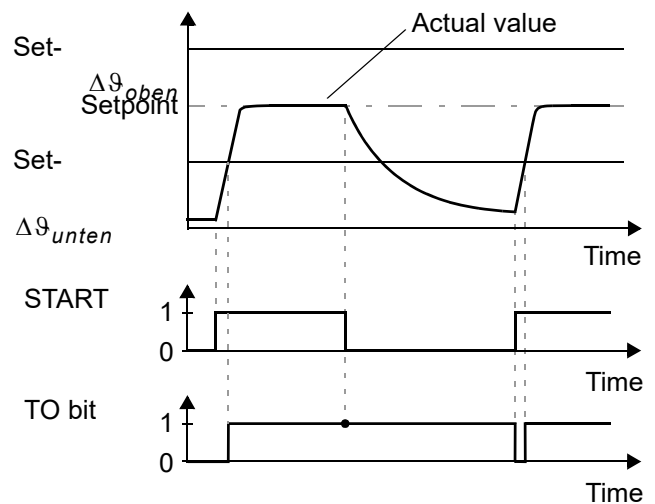

The TO bit can only be set via the parameter data in the CANopen/CAN master. Setting over the ROPEX visualisation software is not possible.

The tolerance limits can be set up to max.  $\pm 99$  K.

### 9.3.7 Control active (RA)

The RESISTRON<sup>®</sup> Temperature Controller RES-5009 has successfully accepted the START request and is in the control mode when RA bit = 1.

### 9.3.8 Information active (IA)

The IA bit is intended for later use and is currently not supported (always 0).

### 9.3.9 Standby active (SA)

The SA bit has the following functions:

#### The so-called "handshake" procedure for the RS bit (reset).

The following prerequisite must be fulfilled for the "handshake" procedure:

- The 24 V supply of the controller and the line voltage are switched on.

The SA bit becomes active when the RS bit (reset) **or** the MP bit (measurement pause) are set to "1" ("handshake" procedure). In this way, the control detects when the controller has accepted the RS bit or the MP bit. The temperature controller can then delete the RS bit or the MP bit again.

#### The controller waits for line voltage.

The following prerequisite must be fulfilled for this function:

- The 24 V supply of the controller is switched on.

The SA bit becomes active when the temperature controller is waiting for the line voltage to be switched on for the first time.

### Behaviour of the temperature controller

In order to be able to assess the behaviour of the temperature controller, you will find examples of the statuses of the voltage supply and the resulting statuses of the controller in the table. The table represents a chronological sequence.

	24 V supply of the controller	Line voltage	Bit set (1) or not set (0)		Status of bits/result
			Input data	Output data	
1.	Off	Off			Temperature controller and control of the machine do not communicate.
2.	On	Off	RS bit = 0	SA bit = 1 AL bit = 0	No reset, standby active, no alarm
					The SA bit is active, because the line voltage is switched off.
3.	On	On	RS bit = 0	SA bit = 0 AL bit = 0	No reset, no standby active, no alarm
					The sealing process is possible.
4.	On	Off	RS bit = 0	SA bit = 0 AL bit = 1	No reset, no standby active, alarm active
					Error code 201 The line voltage is missing.

	24 V supply of the controller	Line voltage	Bit set (1) or not set (0)		Status of bits/result
			Input data	Output data	
5.	On	On	RS bit = 0	SA bit = 0 AL bit = 1	no reset, no standby active, alarm active
					Error code 201 Line voltage is present, but the alarm is not acknowledged.
6.	On	On	RS bit = 1	SA bit = 1 AL bit = 1	Reset active, standby active ("handshake" procedure), alarm active
					Error code 201 As long as the RS bit is set to "1", error code 201 will continue to be displayed. To set the AL bit to "0", acknowledge the error (↪ section 9.15 "Error messages" on page 51).
7.	On	On	RS bit = 0	SA bit = 0 AL bit = 0	1 no reset, no standby active, no alarm
					The alarm is acknowledged, i. e. the error is cleared, and reset is completed. The controller sets the SA bit to "0". The sealing process is possible.

1. If the alarm is acknowledged, but the line voltage is still switched off, error code 901 will immediately be displayed. If the line voltage is then switched on and the alarm is acknowledged once again, the temperature controller goes into control mode.

### Note

In order to determine whether the temperature controller is ready for the sealing process, the alarm active (AL) **and** standby active (SA) bits must be queried. If both bits are set to "0", all prerequisites are fulfilled and the sealing process is possible (↪ section 9.3.3 "Alarm active (AL)" on page 35).

### 9.3.10 Measurement interruption (MU)

The MU bit is active as long as the RESISTRON<sup>®</sup> Temperature Controller RES-5009 does not perform a temperature measurement during the regulation phase (start request active). This can occur when the actual value is larger than the setpoint value (setpoint exceeded). This can be used, for example, to evaluate whether measurement interruptions occur during the heating impulse. This would then be an indication of excessive temperature, which can result in a bad welding seam.

As soon as a measurement is performed again, the MU bit goes back to 0.

### 9.3.11 Actual value

The resolution of the actual value is 1 °C. In the event of an alarm or during calibration, the actual value is 0. The representation of the value is protocol-specific.

### Further information

- CANopen: Signed value as per CANopen specification
- ROPEX CAN: ↪ section 11.5.5 "Querying ACTUAL temperature" on page 85
- ROPEX CAN: ↪ section 11.6.2 "Acknowledgement message" on page 90

### 9.3.12 Start temperature

The start temperature is the temperature measured directly before execution of a start request (ST bit = 1). This measurement value can be used to evaluate the cooling. The value is valid only during the heating phase (ST bit = 1). Outside of this phase, the value "-99 °C" is output, with which it can be differentiated whether or not the value is valid. The value range lies between -20°C and 500°C.

### 9.3.13 Error numbers

If an alarm is present (AL bit = 1), the error number allows determination of the exact cause of the error. (↪ section 9.15 "Error messages" on page 51).

## 9.4 Parameter data

The parameter data contain values for

- the selection of the heating element alloy,
- the temperature range,
- the lower and upper tolerance band limits for temperature monitoring,
- the calibration temperature,
- the measurement impulse duration (only for special applications).

The parameter data can be transmitted at every system start from the CANopen/CAN master to the RESISTRON<sup>®</sup> Temperature Controller RES-5009. In addition, the parameters can be sent at any time via write/read accesses from the CANopen/CAN master to the controller or queried by the controller.

The protocol-specific access as well as the storage of parameter data is explained for CANopen in chapter ↪ section 10.7.2 "Parameter data" on page 65 and for ROPEX-CAN in chapters and ↪ section 11.5 "Receiving CAN messages" on page 79 and section 11.6 "Sending CAN messages" on page 85.

### 9.4.1 Temperature range and alloy

With this parameter, both the temperature range and the heating element alloy can be selected. By changing the standard value (10), the setting of the rotary coding switch (↪ section 8.2.2 "Configuration of the rotary coding switch for temperature range and alloy" on page 22) can be overwritten.

After a change of this parameter, the AUTOCAL function must be performed.

### Further information

- CANopen: ↪ section 10.14 "Temperature range and alloy" on page 74
- ROPEX CAN: ↪ section 11.5 "Receiving CAN messages" on page 79 (address 0008<sub>h</sub>)

### 9.4.2 Lower threshold for temperature OK

Lower threshold value for the "good window".

See section 9.3.6 "Temperature OK (TO)" on page 35 and section 9.4.7 "Temperature diagnosis" on page 42.

### 9.4.3 Upper threshold for temperature OK

Upper threshold value for the “good window”.

See section 9.3.6 "Temperature OK (TO)" on page 35 and section 9.4.7 "Temperature diagnosis" on page 42.

### 9.4.4 Variable calibration temperature

The calibration temperature is set as standard to 20°C. It can be changed between 0°C and 40°C and thus adapted to the temperature of the cooled-off heating element.

With some CANopen/CAN masters, the parameter data cannot be changed during operation. Adjustment of the calibration temperature to the current ambient conditions in the machine is then not possible.

The calibration temperature can therefore be released for setting through the input data by specifying the value “-1” in the parameter data. Specification of the calibration temperature is then made through the input data “Setpoint/AC temperature” (↪ section 9.2.1 "AUTOCAL (AC) automatic zero calibration" on page 30).

After a change of the calibration temperature, the AUTOCAL function must be performed.

#### Further information

- CANopen: ↪ section 10.7.2 "Parameter data" on page 65 (CANopen object 4003<sub>h</sub>)
- ROPEX CAN: ↪ section 11.5 "Receiving CAN messages" on page 79 (addresses 0006<sub>h</sub>, 001A<sub>h</sub>...0020<sub>h</sub>)

### 9.4.5 Measurement impulse duration

The length of the measurement impulses generated by the RESISTRON® Temperature Controller RES-5009 can be set. For certain applications, it can be necessary to lengthen the measurement impulse beyond the standard 1.7 ms.

#### Further information

- CANopen: ↪ section 10.7.2 "Parameter data" on page 65 (CANopen object 4006<sub>h</sub>)
- ROPEX CAN: ↪ section 11.5 "Receiving CAN messages" on page 79 (address 0012<sub>h</sub>)

### 9.4.6 Automatic phase correction (AUTOCOMP)

In special welding applications, it may be necessary to compensate the phase displacement between the  $U_R$  and  $I_R$  measurement signals (↪ ROPEX application report). The phase displacement is executed with the AUTOCOMP function.

The AUTOCOMP function must be enabled for use in the parameter data (↪ section 9.4 "Parameter data" on page 39) (standard setting: AUTOCOMP off).

The following settings are possible:

1. “Off” (factory setting)  
AUTOCOMP function switched off.
2. “On”

The AUTOCOMP function is carried out when the AUTOCAL function (↪ section 9.2.1 "AUTOCAL (AC) automatic zero calibration" on page 30) has been called up quickly twice in sequence. The pause between the end of the first and start of the second execution of AUTOCAL must be less than 2.0 seconds. The second execution of AUTOCAL lasts only about 2.0 seconds and contains the AUTOCOMP function.

If the pause between the two executions is longer than 2.0 seconds, the normal AUTOCAL function is carried out the second time.

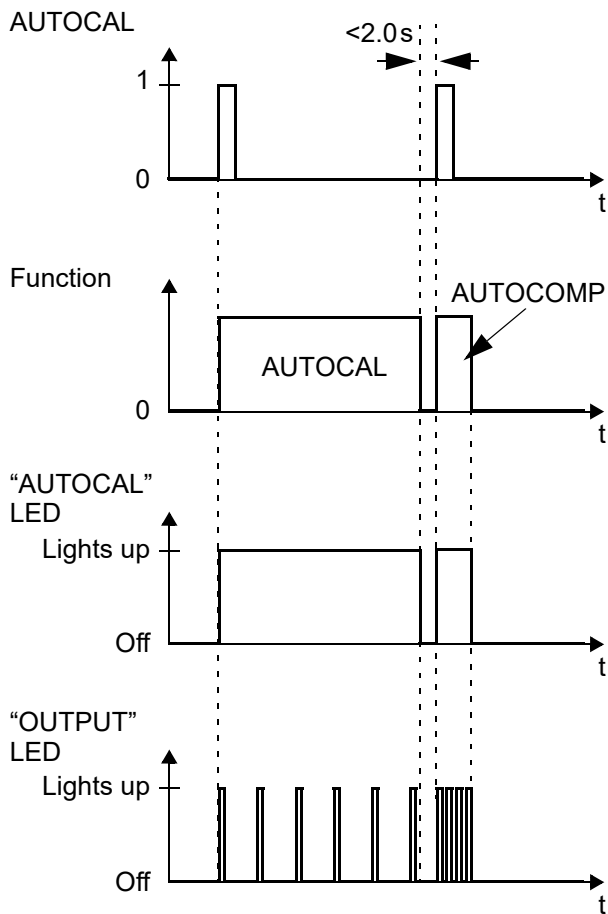

While executing the function AUTOCOMP, the “OUTPUT” LED blinks several times and the actual value output (terminals 17+7) goes to  $0\dots3\text{ }^{\circ}\text{C}$  (i. e. approx. 0 VDC).

### 3. “AUTO”

With this setting, the AUTOCOMP function is automatically started after a successful execution of the AUTOCAL function.

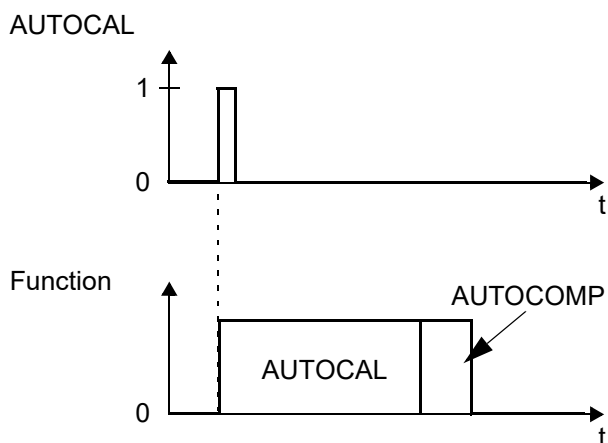

While executing the function AUTOCOMP, the “OUTPUT” LED blinks several times and the actual value output (terminals 17+7) goes to  $0\dots3\text{ }^{\circ}\text{C}$  (i. e. approx. 0 VDC).

### Further information

- CANopen: ↪ section 10.7.2 "Parameter data" on page 65 (CANopen object 4010<sub>h</sub>)
- ROPEX CAN: ↪ section 11.5 "Receiving CAN messages" on page 79 (address 0013<sub>h</sub>)

### 9.4.7 Temperature diagnosis

An additional temperature diagnosis can be activated in the parameter data. The RESISTRON<sup>®</sup> Temperature Controller RES-5009 checks if the ACTUAL temperature within an settable tolerance band "OK window" is found on either side of the SETPOINT temperature. The lower ( $\Delta\vartheta_{unten}$ ) and upper ( $\Delta\vartheta_{oben}$ ) tolerance band limits are the same as with the "Temperature OK" monitoring (TO bit, ↪ section 9.3.6 "Temperature OK (TO)" on page 35). The limits are set at the factory to -10 K and +10 K, respectively.

If the ACTUAL temperature is within the specified tolerance band after activation of the START signal, the temperature diagnosis will be switched on. If the ACTUAL temperature leaves the tolerance band, the related error nos. 307, 308 are output and the alarm output switches on (↪ section 9.15 "Error messages" on page 51).

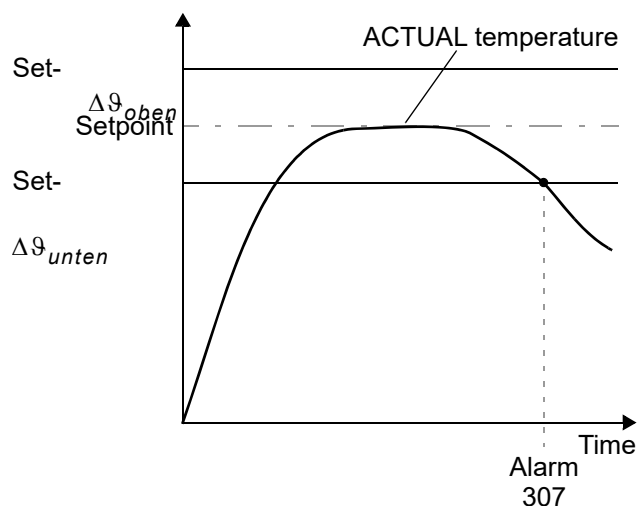

If the temperature diagnosis has not been activated before the START signal is deactivated (i. e. the ACTUAL temperature has not exceeded the lower tolerance band limit or has not dropped below the upper tolerance band limit), the related error nos. 309, 310 are output and the alarm relay switches on.

A delay time (0...9.9 s) can additionally be set in the parameter data. After the lower tolerance band limit is exceeded, the temperature diagnosis takes place only after the parametrised delay time has expired. As a result, the temperature diagnosis can be intentionally suppressed, e. g. during a temperature drop caused by closing the tool.

The lower and upper tolerance band limits cannot be set through the ROPEX visualisation software. These are the same limits as with the TO bit. These can only be set via the parameter data (↪ section 9.4 "Parameter data" on page 39).

### Further information

- CANopen: ↪ section 10.7.2 "Parameter data" on page 65 (CANopen objects 400D<sub>h</sub> and 400E<sub>h</sub>)
- ROPEX CAN: ↪ section 11.5 "Receiving CAN messages" on page 79 (addresses 000F<sub>h</sub>, 0010<sub>h</sub>)

### 9.4.8 Heat-up time monitoring

An additional heat-up time monitoring can be activated in the parameter data.

The heat-up time monitoring is activated with the start request. The RESISTRON<sup>®</sup> Temperature Controller RES-5009 then monitors the time until the ACTUAL temperature has reached 95% of the setpoint temperature. If

this takes longer than the parameterised time, error no. 304 is output and the alarm output switches on (↪ section 9.15 "Error messages" on page 51).

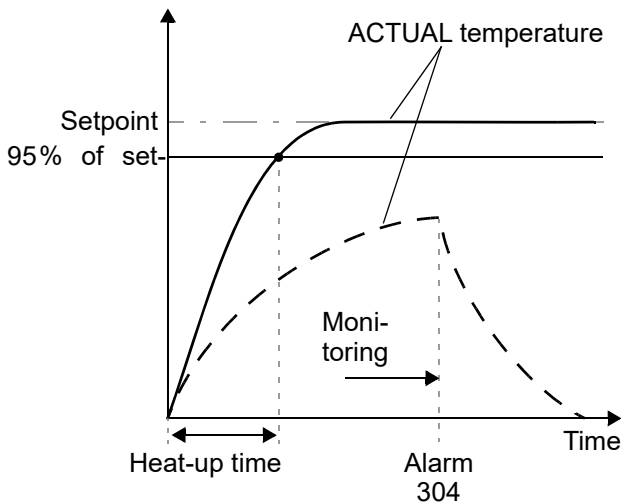

The Heat-up time monitoring function must be enabled for use in the parameter data (standard setting: Heat-up time monitoring off).

#### Further information

- CANopen: ↪ section 10.7.2 "Parameter data" on page 65 (CANopenobject 400F<sub>h</sub>)
- ROPEX CAN: ↪ section 11.5 "Receiving CAN messages" on page 79 (address 0011<sub>h</sub>)



#### CAUTION

The heat-up time monitoring function is only available for the start signal transmitted via CAN and the 24 VDC signal START 0. There is no heat-up time monitoring for the 24 VDC signal START 1

### 9.4.9 Hold mode

The behaviour for the output of the ACTUAL temperature via the CANopen/CAN protocol can be parameterised via the parameter data as follows:

1. **“Off” (factory setting)**  
The current ACTUAL temperature is always output in real time.
2. **“On”**  
The same ACTUAL temperature that was current at the end of the last welding phase is output. After the controller is switched on, the real ACTUAL temperature is displayed until the end of the first heating phase.
3. **“2 Sec.”**  
At the end of a welding phase, the current ACTUAL temperature is output for a further 2 seconds via the CANopen/CAN protocol. Afterwards, the ACTUAL temperature is output again in real time until the end of the next welding phase.

The Hold mode only affects output of the ACTUAL temperature over the CANopen/CAN protocol and the numeric temperature display in the ROPEX visualisation software.

Output of the ACTUAL temperature over the analogue output of the controller or the graphic drawing in the ROPEX visualisation software is not changed by this.

The different Hold modes are depicted in the following image:

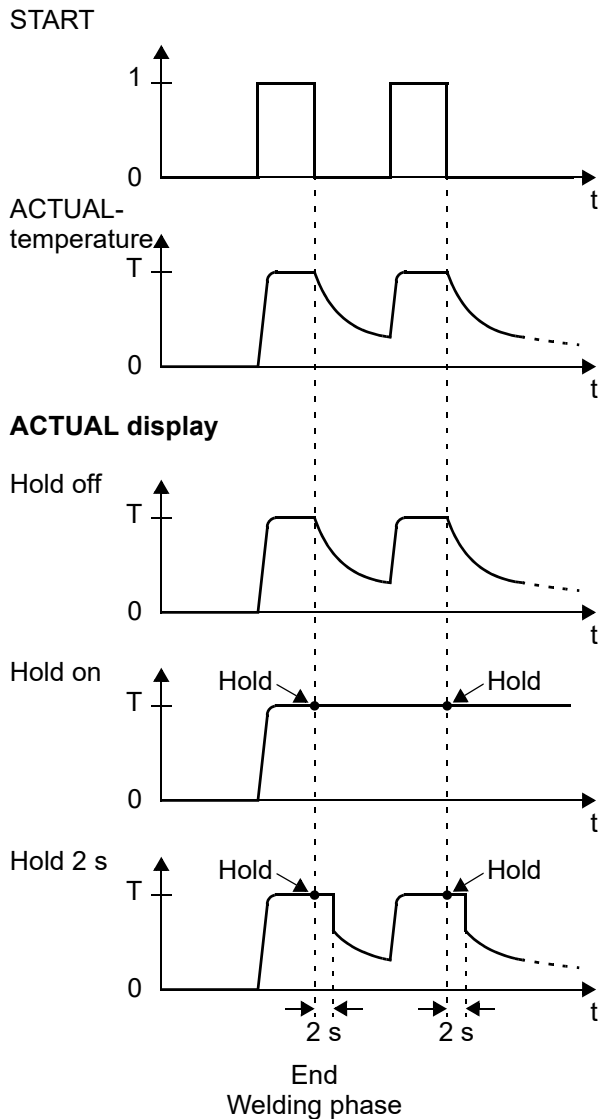

#### Further information

- CANopen: ↪ section 10.7.2 "Parameter data" on page 65 (CANopen object 4012<sub>h</sub>)
- ROPEX CAN: ↪ section 11.5 "Receiving CAN messages" on page 79 (address 0009<sub>h</sub>)

#### 9.4.10 Start-up delay after reset

After acknowledging an alarm with the reset signal (RS bit), the RESISTRON<sup>®</sup> Temperature Controller RES-5009 waits until a possibly connected contactor has closed the heating circuit again. Only after this waiting time has elapsed, measurement impulses will be generated again in order to determine the current ACTUAL temperature and to carry out error diagnoses. This start-up delay is 0.2 s by default and can be adjusted with the CANopen object 0x4014. Thus, slower switching contactors can also be used. The start-up delay cannot be set in the ROPEX CAN protocol.

#### 9.4.11 Maximum measurement pause

If the RESISTRON<sup>®</sup> Temperature Controller RES-5009 in control mode (ST bit = 1) detects that the current ACTUAL temperature is greater than the setpoint, the power supply in the heating element will be reduced. If the

power reduction is not sufficient, the low-power measurement impulses are suspended to determine the current ACTUAL temperature. This measurement pause can last up to 10 periods in the standard setting. During this measurement pause, the controller cannot respond to a change in the ACTUAL temperature. The status bit "Measurement interruption active" (↪ section 9.3.10 "Measurement interruption (MU)" on page 38) is active at this time (MU bit = 1).

In certain applications it may be useful to shorten this maximum measurement pause, e. g. if the higher ACTUAL temperature values are measurement errors. For this case, the maximum measurement pause can be shortened with the CANopen object 0x4015.

The maximum measurement pause cannot be set in the ROPEX CAN protocol.



### CAUTION

A measurement pause that is set too short can lead to an increased temperature if the system is incorrectly dimensioned (secondary voltage of the pulse transformer too large) or if the sealing temperatures are low.

## 9.5 Undervoltage detection

The flawless functioning of the RESISTRON<sup>®</sup> Temperature Controller RES-5009 is guaranteed for the tolerance range of the line voltage and 24 VDC supply voltage specified in section 15 "Technical data" on page 93.

If the 24 VDC supply voltage falls below the permitted tolerance range, the controller switches to a standby mode. Welding processes and measuring impulses are no longer carried out. If the input voltage is within the specified tolerance range again, operation will be continued. As an indication of the standby state, 0...3 °C (i. e. approx. 0 V) is output at the analogue output. In addition, the SA bit is set in the controller status.



### WARNING

The flawless functioning of the RESISTRON<sup>®</sup> Temperature Controller RES-5009 is guaranteed only within the specified tolerance range of the input voltage. An external voltage monitoring device must be used to avoid faulty welding if the line voltage or the 24 VDC supply voltage is too low.

## 9.6 Temperature display (actual value output)

The RESISTRON<sup>®</sup> Temperature Controller RES-5009 delivers an analogue signal 0...10 VDC at the terminals 17+7. The analogue signal is proportional to the real ACTUAL temperature.

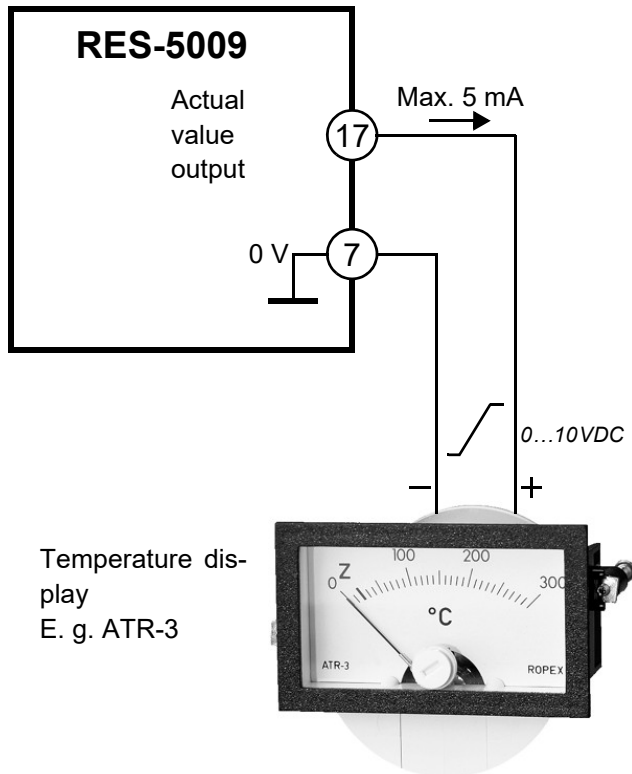

Voltage values:

0 VDC → 0 °C

10 VDC → 300 °C (ATR-3) or 500 °C (ATR-5), depending on the device configuration.

The correlation between the change in the output voltage and the ACTUAL temperature is linear.

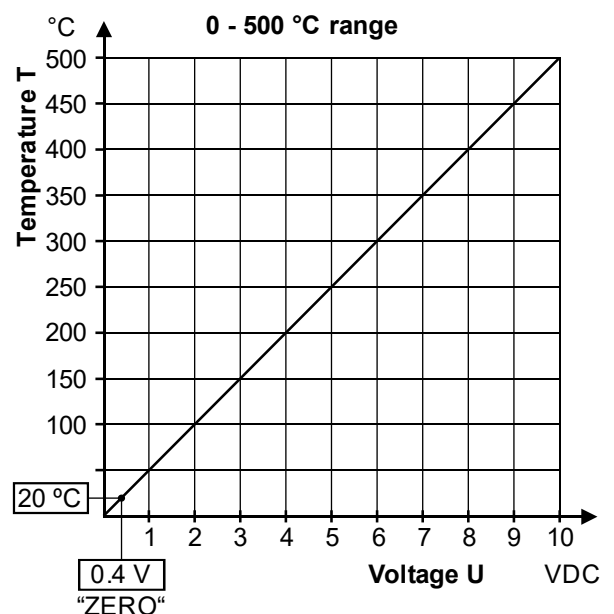
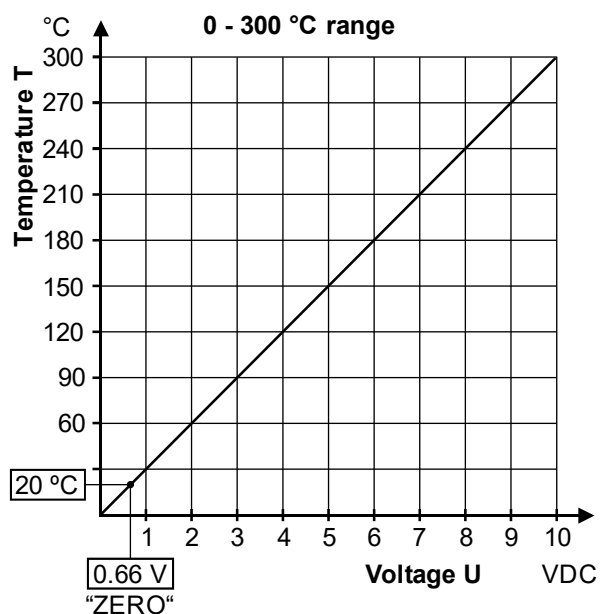

A display instrument can be connected to this analogue output for visualisation of the heating element temperature.

The ROPEX temperature display ATR-x in its overall characteristics (size, scaling, dynamic behaviour) is optimally suited for visualisation and can be used for this, if needed (↪ section 18 "How to order" on page 97).

The following criteria can be assessed or checked with the ROPEX temperature indicator ATR-x:

- TARGET-ACTUAL comparisons
- Heat up speed,
- Reaching the setpoint in the specified time
- Cooling of the heating element
- Faults in the control circuit (loose contacts, contacting and wiring problems)
- Network faults
- mutual interference of several neighbouring control circuits.

In case of alarm, this analogue output is used to output differentiated error messages (↪ section 9.15 "Error messages" on page 51).

## 9.7 Booster connection

The RESISTRON<sup>®</sup> Temperature Controller RES-5009 has a connection for an external switching amplifier (booster) as standard. The connection of an external switching amplifier (at the terminals 15+7) is required at high primary currents (constant current > 5 A, impulse current > 25 A). The switching amplifier must be connected in accordance with section 7.7 "Wiring diagram with booster connection" on page 20.



### CAUTION

In order to avoid the EMC interference, the connection cable to the external switching amplifier may not exceed a length of 1 m and has to be twisted.

## 9.8 USB interface for visualisation software ROPEXvisual<sup>®</sup>

A USB interface (type micro-USB) is available for system diagnosis and process visualisation. A data connection can be built up with the ROPEX visualisation software ROPEXvisual<sup>®</sup> over this USB interface.

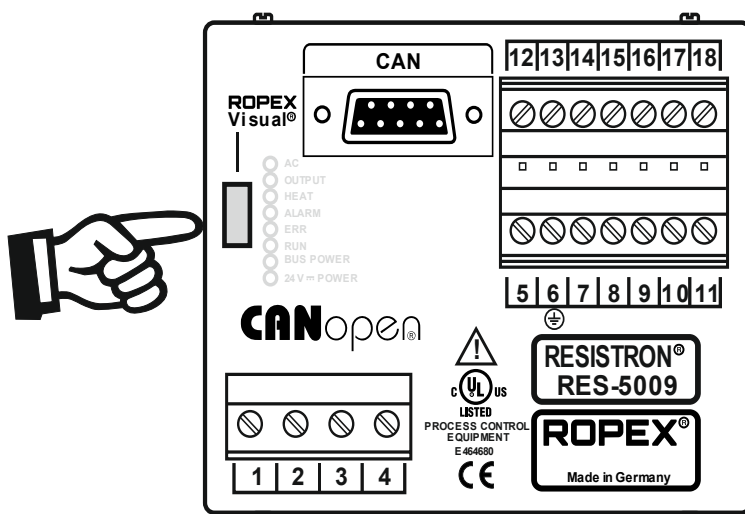

With the ROPEX visualisation software ROPEXvisual<sup>®</sup> the following may happen

- error messages may be read out
- Temperature curves may be recorded
- Status bits may be displayed
- Parameters may be set
- manual triggering of welding pulses can be generated during startup

The ROPEX-Visualisation software ROPEXvisual<sup>®</sup> is intended for startup and the error diagnosis. Permanent records of the sealing parameters cannot be created with this. The recording of the sealing parameters or status bits must be done within the machine control. A separate document is available for the ROPEX-visualisation software ROPEXvisual<sup>®</sup>.

The software and the documentation are available in the (search term: "Visual").

## 9.9 AUX interface

Internal interface for diagnosis and maintenance. The interface is currently not available.

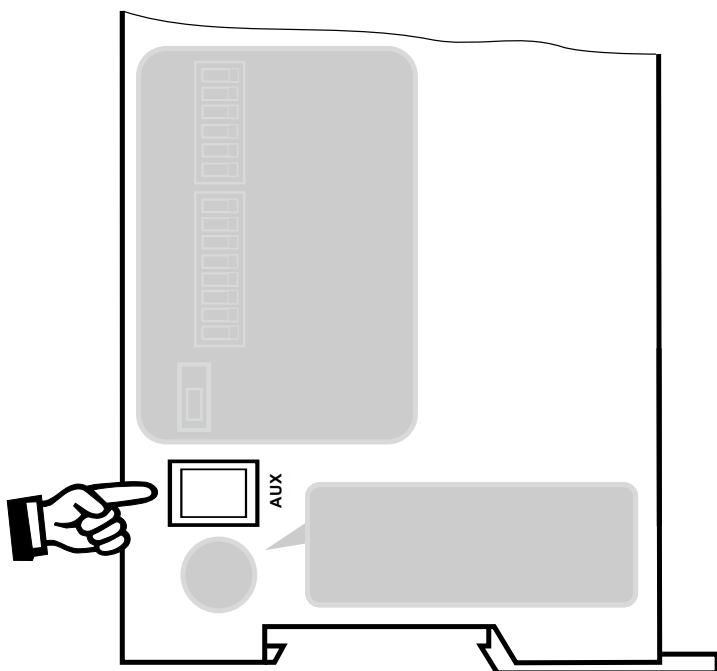

## 9.10 Total cycles counter

From the time of delivery of the RESISTRON<sup>®</sup> Temperature Controller RES-5009, the number of welding cycles performed (ST bit = 1) is stored in the controller. This counter can only be displayed, but not reset. Display is possible with the ROPEX visualisation software (↪ section 9.8 "USB interface for visualisation software ROPEXvisual<sup>®</sup>" on page 47) or via the services of the CAN interface.

## 9.11 Operating hours counter

From the time of delivery of the RESISTRON<sup>®</sup> Temperature Controller RES-5009, the operating hours are stored in the controller. The operating hours counter works with an accuracy of 6 minutes. The operating hours can be displayed, but not reset. Display is possible with the ROPEX visualisation software (↪ section 9.8 "USB interface for visualisation software ROPEXvisual<sup>®</sup>" on page 47) or via the services of the CAN interface.

## 9.12 Data storage for error messages and AUTOCAL

To make error diagnosis easier in ongoing operation, the RESISTRON<sup>®</sup> Temperature Controller RES-5009 has a data storage for error messages (↪ section 9.15 "Error messages" on page 51) and executed AUTOCAL procedures (↪ section 9.2.1 "AUTOCAL (AC) automatic zero calibration" on page 30).

The last 400 messages are stored. The messages are read out and displayed with the ROPEX visualisation software (↪ section 9.8 "USB interface for visualisation software ROPEXvisual<sup>®</sup>" on page 47).

The RESISTRON<sup>®</sup> Temperature Controller RES-5009 also has an integrated clock (↪ section 9.13 "Integrated clock (date and time)" on page 49). The messages are then stored with the indication of date and time (time stamp).



### NOTE

The stored messages can be exported as a csv-file. If needed, ROPEX can evaluate the exported file and create an error diagnosis.

## 9.13 Integrated clock (date and time)

The RESISTRON<sup>®</sup> Temperature Controller RES-5009 has an integrated clock. The error messages and executed AUTOCAL procedures are stored in the data storage (↪ section 9.12 "Data storage for error messages and AUTOCAL" on page 49) with the indication of date and time (time stamp). This enables a more precise assignment of error messages when analyzing problems, for example.

The integrated clock can be set and read out through the ROPEX visualisation software (↪ section 9.8 "USB interface for visualisation software ROPEXvisual<sup>®</sup>" on page 47) or through services of the CAN interface.

A maintenance-free capacitor is used for operation of the clock. There is no battery installed, so there is no need to change the battery.

- The controller must be switched on for at least 3 hours to fully charge the capacitor for the clock.
- If the controller is switched off, a fully charged capacitor can operate the clock for approx. 2...4 weeks.
- If the controller is switched off longer, the date and time must be set again.

The capacitor is discharged when shipped from the factory. During initial startup of the controller, the clock must be set when the error messages in the data storage (↪ section 9.12 "Data storage for error messages and AUTOCAL" on page 49) are to be stored with date and time.

Operation of the controller is possible without the clock being set. In this case, invalid values for date and time will be stored in the data storage (↪ section 9.12 "Data storage for error messages and AUTOCAL" on page 49). The behaviour of the temperature control is not influenced by this.

### Further information

- CANopen: ↪ section 10.17 "Date and time in CANopen" on page 75
- CANopen: ↪ section 10.18 "CANopen Time stamp object" on page 76
- ROPEX CAN: ↪ section 11.7 "Reading and setting the internal clock" on page 91

## 9.14 System monitoring/alarm output

To increase the operational safety and to avoid incorrect seals, the RESISTRON® Temperature Controller RES-5009 has a differentiated error message and diagnosis. Both the outer wiring and the internal system are monitored by hardware and software measures. The system monitoring supports the operator in localising a defective operating status.

A system fault is reported or differentiated through the following elements.

### A.) Red “ALARM” LED at the controller lights up with three statuses:

#### 1. Blinks quickly (4 Hz):

The AUTOCAL function must be carried out  
(Error Nos. 8 + 9, or 104...106, 211, 302, 303).

#### 2. Blinks slowly (1 Hz):

System configuration is not correct and therefore the zero calibration (AUTOCAL function) carried out was not successful (↪ section 8.2 "Device configuration" on page 21).  
(Error nos. 10...12, or 111...114)

#### 3. Lights up permanently:

Faults prevent startup  
(Error nos. 1...7, or 101...103, 107, 108, 201...203, 307, 308, 9xx).  
These are usually external wiring errors.

### B.) Alarm relay (relay contacts terminals 12+13+14):

In the factory setting, the alarm relay is:

- **NOT ACTIVE** in the operating states “Blinks quickly” (A.1) or “Blinks slowly” (A.2.). The alarm relay is activated, however, if a START signal is given in one of these states.
- **ACTIVE** in the operating state “lights up permanently” (A.3.)



#### CAUTION

If the alarm relay is configured differently than in the factory setting (↪ section 8.2.3 "Configuration of the alarm relay" on page 23), these statuses are inverted.

### C.) Output of the error numbers over the CAN protocol

If there is an error, Alarm will be set active (AL bit). The error number is displayed in CAN protocols.

### D.) Output of the error number via actual value output 0...10 VDC (terminal 17+7):

**As a temperature display is not required in case of a fault, the actual value output is used to output the error in case of alarm.**

- 13 voltage levels are output within the 0...10 VDC range. One error number is assigned to each voltage level. (↪ section 9.15 "Error messages" on page 51).
- In case of error nos. 104...106, 114, 211, 302, 303 (AUTOCAL must be carried out) and in case of error nos. 111...113, (system configuration is not correct), the actual value output alternates between the voltage value that corresponds to the error and the final value (10 VDC, i. e. 300 °C or 500 °C) at 1 Hz. If the “START signal is given, the voltage value does not alternate any more.
- An alarm message can be reset by a reset request or by switching the controller off and on.

Invalid alarm messages can occur when the controller is switched off due to the undefined operating status. To avoid false alarms, this must be taken into account during evaluation in the higher-level controller (e. g. PLC).

## 9.15 Error messages

The following table shows the assignment of the error numbers output in the CAN protocol to the errors that occurred. The cause for the errors and the necessary measures to remedy them are described.

The schematic circuit diagram in section 9.16 "Error ranges and causes" on page 56 permits fast and efficient error remedy.

The RESISTRON<sup>®</sup> Temperature Controller RES-5009 displays 13 voltage levels for error diagnosis via the actual value output. Internally in the controller, the error messages are differentiated in even more detail. The 3-digit error numbers described in brackets are displayed via the CAN interface and with the ROPEX visualisation software (↪ section 9.8 "USB interface for visualisation software ROPEXvisual<sup>®</sup>" on page 47). The error search can thus be performed even more effectively.



### **CAUTION**

**In order to avoid incorrect evaluations, the evaluation of the actual value output for the detection of an error message – e. g. in the higher-level control – must be carried out with an adapted tolerance window. The tolerances of the actual value output must be observed ( section 15 "Technical data" on page 93)**

### Part 1 of 3: Error messages (faults)

**NOTE:** The specified error messages are output as faults:

- Actual value output displays constant error voltage
- Alarm LED lights up continuously
- Alarm relay is active

Error no.	Actual value outp. Voltg. [V]	Cause	Measure during initial startup	Measure during machine operation, heating element not changed	
1	101	0.66	Current signal missing	Error area ①	Error area ①
2	102	1.33	Voltage signal missing	Error area ③	Error area ③
3	103	2.00	Voltage and current signals missing	Error area ②	Error areas ② ⑨
4	107	2.66	Temperature drop	Error ranges ④ ⑤ ⑥ ("Loose contact")	Error ranges ④ ⑤ ⑥ ("Loose contact")
	108		Temperature spike		
	307		Temperature too low, leave the tolerance band (↪ Chap. 9.4.7)	Check the dimensioning of the pulse transformer, Check heat removal through the sealing process, Verify application through sealing tests	-
	308		Temperature too high, leave tolerance band (↪ Chap. 9.4.7)		
	309		Temperature too low, tolerance band not reached (↪ Chap. 9.4.7)		
	310		Temperature too high, tolerance band not reached (↪ Chap. 9.4.7)		
5	201	3.33	Line frequency missing/fluctuates	Check line: Line frequency Harmonic waves Voltage fluctuations	Check line: Line frequency Harmonic waves Voltage fluctuations
	202		Line frequency too large/fluctuates		
	203		Line frequency too small/fluctuates		
6	304	4.00	Heat-up time too long (↪ chap. 9.4.8)	Perform <b>RESET</b> Check the dimensioning of the pulse transformer, Verify the parametrised heating time, Check lines and contacts	Perform <b>RESET</b> Check lines and contacts, Verify the sealing process

**Part 1 of 3: Error messages (faults)**

**NOTE:** The specified error messages are output as faults:

- Actual value output displays constant error voltage
- Alarm LED lights up continuously
- Alarm relay is active

Error no.		Actual value outp. Voltg. [V]	Cause	Measure during initial startup	Measure during machine operation, heating element not changed
7	901	4.66	Line voltage/synchronising signal missing	Replace device	Replace device
	913		Triac defective	Replace device	Replace device
	914		Int. error, device defective	Replace device	Replace device
	915				
	916				
	917		Incorrect slide switch for alarm output	Check slide switch	Check slide switch
918					

**Part 2 of 3: Error messages (warnings)**

**NOTE:** The specified error messages are first output as warnings:

- Actual value output changes between two values
- Alarm LED blinks quickly
- Alarm relay is not active

After activation of the START signal, the output occurs as a fault:

- Actual value output does not change any more, see bold italic values
- Alarm LED lights up continuously
- Alarm relay is active

Error no.	Actual value outp. Voltg. [V]	Cause	Measure during initial startup	Measure during machine operation, heating element not changed	
8	104	Current signal incorrect Impulse transformer incor- rectly sized	Perform <b>AUTOCAL</b> , Check transformer speci- fication, Error ranges ⑦ ⑧	Error ranges ④ ⑤ ⑥ ("Loose contact")	
	105	Voltage signal incorrect Impulse transformer incor- rectly sized Strong harmonic waves on power supply			
	106	Voltage and current signal incorrect Impulse transformer incor- rectly sized			
	302	Temperature too low Calibration not performed Loose contact Ambient temperature fluctu- ates	Perform <b>AUTOCAL</b> and/or Error ranges ④ ⑤ ⑥ ("Loose contact")		
	303	Temperature too high Calibration not performed Loose contact Ambient temperature fluctu- ates			
9	211	↔ <b>6.00</b> ↔ ↔ 10 ↔	Data error	Perform <b>AUTOCAL</b>	Perform <b>AUTOCAL</b>

**Part 3 of 3: Error messages (warnings)**

**NOTE:** The specified error messages are first output as warnings:

- Actual value output changes between two values
- Alarm-LED blinks slowly
- Alarm relay is not active

After activation of the START signal, the output occurs as a fault

- Actual value output does not change any more, see bold italic values
- Alarm LED lights up continuously
- Alarm relay is active

Error no.		Actual value outp. Voltg. [V]	Cause	Measure during initial startup	Measure during machine operation, heating element not changed
10	111	<b>6.66</b> ↔ 10 ↔	Current signal incorrect, Calibration not possible	Error range ⑧, Check configuration	Error ranges ④ ⑤ ⑥ ("Loose contact")
11	112	<b>7.33</b> ↔ 10 ↔	Voltage signal incorrect, Calibration not possible	Error range ⑦, Check configuration	Error ranges ④ ⑤ ⑥ ("Loose contact")
12	113	<b>8.00</b> ↔ 10 ↔	Voltage/current signal incorrect, Calibration not possible	Error ranges ⑦ ⑧, Check configuration	Error ranges ④ ⑤ ⑥ ("Loose contact")
13	114	<b>8.66</b> ↔ 10 ↔	Temperature fluctuates, Calibration not possible	Perform <b>AUTOCAL</b> and/or Error ranges ④ ⑤ ⑥ ("Loose contact")	Perform <b>AUTOCAL</b> and/or Error ranges ④ ⑤ ⑥ ("Loose contact")
	115		Ext. calibration temperature too high, Calibration not possible	Perform <b>AUTOCAL</b> with ext. calibration temp. ≤40 °C	Perform <b>AUTOCAL</b> with ext. calibration temp. ≤40 °C
	116		Ext. calibration temperature fluctuates, Calibration not possible	Perform <b>AUTOCAL</b> with stable ext. calibration temperature	Perform <b>AUTOCAL</b> with stable ext. calibration temperature

### 9.16 Error ranges and causes

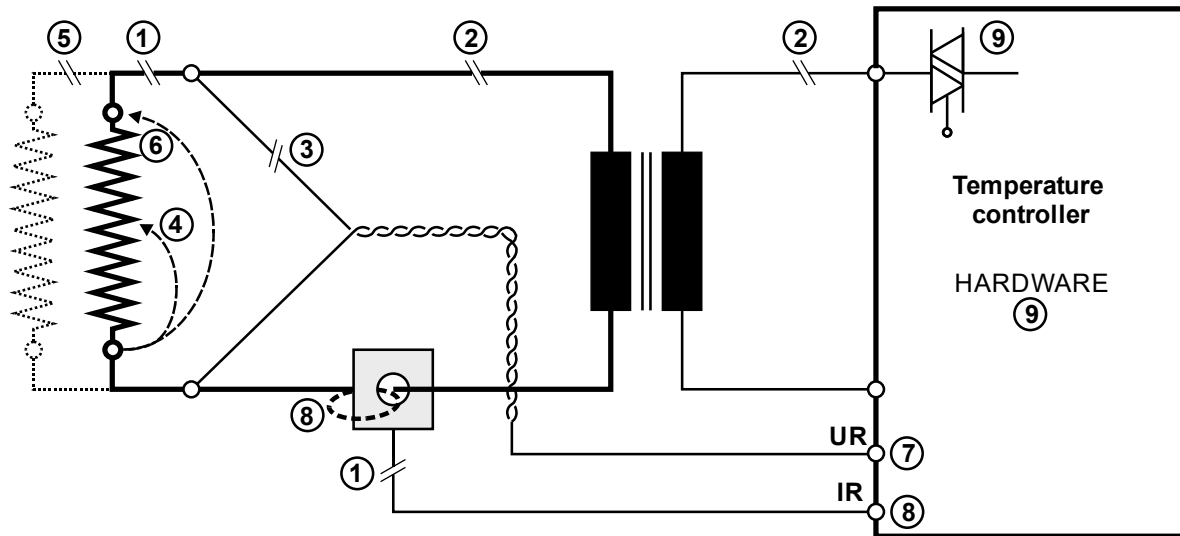

Explanations of the possible error causes can be taken from the following table.

Error range	Explanations	Possible causes
①	Interruption of the load circuit after the $U_R$ pickup point	- Wire break, heating element break - Contacting at the heating element defective
	Interruption of the signal from the transformer	- $I_R$ measurement line from the transformer interrupted
②	Interruption of the primary circuit	- Line break, Triac defective in the controller - Primary coil of the impulse transformer interrupted - Kb fuse open
	Interruption of the secondary circuit in front of the $U_R$ pickup point	- Wire break - Secondary coil of the impulse transformer interrupted
③	$U_R$ signal missing	- Measurement line interrupted
④	Partial short circuit (Delta R)	- Heating element is partially bridged through a conducting part (downholder, counter bar, etc.)
⑤	Interruption of the parallel circuit	- Wire break, heating element break - Contacting at the heating element defective
⑥	Complete short circuit	- Heating element incorrectly installed, insulation at the head of the rail missing or incorrectly installed - Conducting part bridges heating element completely
⑦	$U_R$ signal incorrect	- $U_2$ outside of the permitted range of 0.4...120VAC
⑧	$I_R$ signal incorrect	- $I_2$ outside of the permitted range of 30...500 A
	Coils through transformer incorrect	- Check number of coils (for current < 30 A, two or more coils are required)

Error range	Explanations	Possible causes
⑨	Internal device error/no line voltage	- Hardware error (replace controller) - Slide switch for alarm relay defective or not in correct position - Line voltage missing

## 9.17 Measures in the event of an error

### System incorrectly dimensioned:

The control can function properly only if all components are coordinated with one another. The ROPEX application report fulfils exactly this task and should therefore be implemented in full.

If the system is not designed according to the ROPEX application report, or if the boundary conditions change, this can lead to poor control or even faults.

If your application changes, e. g. by increasing the cycle rate or changing the heating band dimensions, the application report must be adjusted accordingly. Inform us) and we will check what changes have to be made to your system so that the control can work again accurately.

### Check configuration:

In some cases the controller has to be operated outside of the technical specification. If this is the case, the relevant information is given in the ROPEX application report. The adjustments in the control circuit, e. g. by additional system components, or a modification to the controller, is described there. The necessary system components are also listed in the parts list.

Failure to comply with these instructions can lead to operational faults.

### Loose contact:

The most common cause for errors is a loose contact. A loose contact can have several causes and occurs during operation. Before initiating a thorough search for a loose contact, you should first check all connections for a good and tight fit. Among others, weak points can be plugs and very often clamping heads, screw connections and cable lugs.

Requirements for looking for loose contacts:

- We recommend having an electrician to troubleshoot the machine and an employee to operate the machine.
- A continuous Start signal on the temperature controller must be possible, in order to be able to carry out continuous heating.
- It must be ensured that no dangerous movements can take place in the machine during the test, for example, by pressing the emergency stop.

Additional information:

- In case of parallel connections of heating elements, both current circuits must be routed through the current transformer, so that a loose contact can be detected.
- The calibration process (AUTOCAL) must be carried out after changes to the system (cabling, connectors, tightening of screws, ...).

In the following it is described how you can locate a loose contact in your system:

1. Reset the alarm (e. g. press RESET).
2. Generate a continuous Start signal on the controller at a temperature of 75 °C (corresponds to 2.5 V at the analogue output). Make sure that the heating does not lead to a dangerous situation in the machine.
3. The operator of the machine observes the displayed or measured temperature.
4. In the meantime, the electrician checks and moves the lines (high-current lines, measuring lines, ...). All plugs and contact blocks must also be checked by tapping them.
5. As soon as the displayed or measured temperature changes suddenly, the cause for the loose contact will be

found.

If the controller goes into “fault” immediately, when a continuous Start signal is generated, we recommend the following procedure:

1. The machine operator observes the displayed or measured temperature in the idle state.
2. In the meantime, the electrician checks and moves the lines (high-current lines, measuring lines, ...). All plugs and contact blocks must also be checked by tapping them.

**Remarks:**

More time is required for this in the idle state, as measurements only take place every 1.2 seconds.

3. As soon as the displayed or measured temperature changes suddenly, the cause for the loose contact will be found.

If the alarm cannot be reset, the above-mentioned procedures cannot be used. In this case, we recommend that you minimise your control system, e. g. to place a new sealing tool directly in front of the control cabinet and to connect it with new, short cables. Then carry out the AUTOCAL function and repeat the five steps listed above to locate the loose contact.

If the measures described were not successful, please contact us directly (and send the following information to:

- Date and number of the application report and, if applicable, project name, as well as the converted page and column.
- Actual implementation of the sealing application in the machine if this deviates from the application report.
- Relevant pages from its electrical circuit diagram, possibly information on plugs and connections.
- The error numbers that have occurred (can be read e. g. by using the ROPEX visualisation software).
- Error description and measures carried out so far.
- Serial number and production date of the temperature controller.

## 10 CANopen



**CAUTION**

The following descriptions contain only device-specific functions. Please consult your PLC description or the CANopen specifications of the CiA for general information for the CANopen and system configuration.

### 10.1 Electronic Data Sheet (EDS)

Project planning tools for the CANopen master to be projected interpret the content of the EDS files of the devices. From this, the project planning tools generate a parameter set for the CANopen master which controls the user data traffic. The EDS file of the RESISTRON<sup>®</sup> Temperature Controller RES-5009 contains all the information about the controller which is necessary for project planning, e. g. the I/O data description, parameter descriptions, etc.

The EDS file can be requested by e-mail () or downloaded from our homepage

### 10.2 Setting the baud rate

For the operation of the RESISTRON<sup>®</sup> Temperature Controller RES-5009, the CAN baud rate must be set correctly. The baud rate depends on the CANopen network into which the controller is to be integrated.

The baud rate is set by means of four “BAUDRATE” DIP switches. The switches are read in once when the device is started. It is not possible to change the baud rate using a DIP switch during operation.

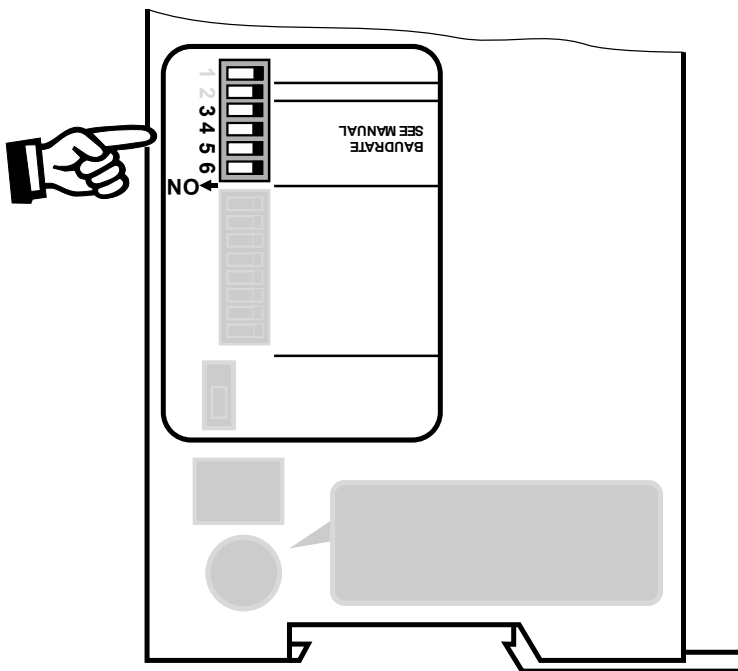

Baud rate		DIP 3	DIP 4	DIP 5	DIP 6
1 MBaud		ON	-	-	-
800 kBaud		-	ON	-	-
500 kBaud		ON	ON	-	-
250 kBaud		-	-	ON	-
205 kBaud (no CANopen standard baud rate)		ON	-	ON	-
125 kBaud		-	ON	ON	-
100 kBaud (no CANopen standard baud rate)		ON	ON	ON	-
50 kBaud		-	-	-	ON
20 kBaud		ON	-	-	ON
10 kBaud		-	ON	-	ON
AutoBaud with Layer Setting Services (LSS)	CANopen Node address: 0	-	-	-	-
AutoBaud	CANopen Node address: not equal to 0				

The switch position '-' means off.

“AutoBaud” is active for all switch combinations not listed.

The automatic baud rate detection “AutoBaud” only works if the controller is in a CANopen network in which at least two participants are already exchanging valid CAN messages.

As long as the correct baud rate has not been detected, the controller behaves passively on the CAN bus and

does not influence the existing communication. The controller can only detect the baud rates listed above, other baud rates cannot be detected.



#### CAUTION

If the baud rate in the CAN network is changed during operation, the controller must be switched off and on again so that the "AutoBaud" function is active again.

If all switches are set to off and the CANopen node address is set to 0, "LSS" (Layer Setting Services) is active in addition to the automatic baud rate detection "AutoBaud". "LSS" can be used to assign the node address of a device via CANopen service and to set the baud rate (↪ section 10.4 "LSS" on page 61).



#### CAUTION

When baud rate detection "AutoBaud" or "LSS" is active, the ERR LED (red) and RUN LED (green) flicker alternately.

### 10.3 Setting the CANopen node address

For the operation of the RESISTRON<sup>®</sup> Temperature Controller RES-5009, the CANopen node address must be set correctly. The CANopen node address depends on the CANopen network into which the controller is to be integrated. A unique node address must be assigned for each CANopen device.

The CANopen node address is set by means of seven DIP switches "IDENTIFIER / NODE ID". The values 1 to 127 are valid as CANopen node address. The switches are read in once when the device is started. It is not possible to change the CANopen node address using DIP switches during operation. DIP switch 8 has no influence on the CANopen node address.

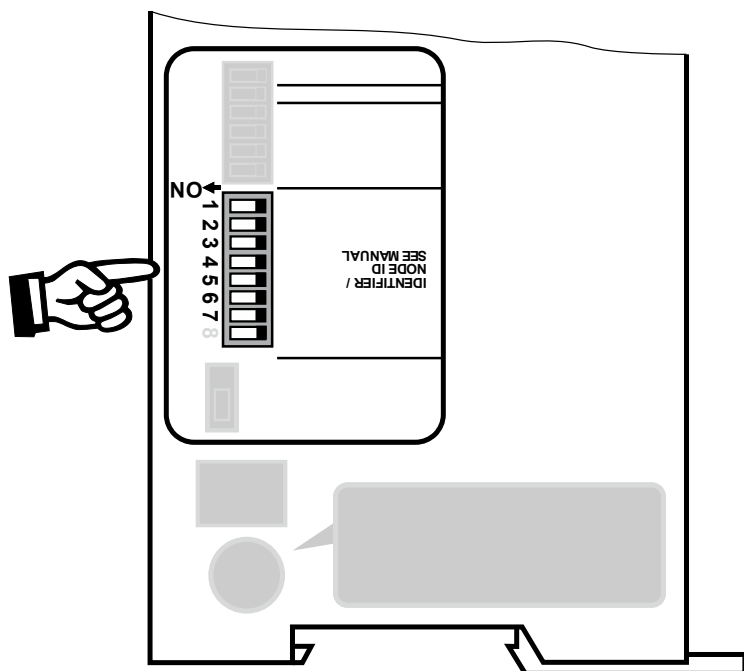

DIP 7	DIP 6	DIP 5	DIP 4	DIP 3	DIP 2	DIP 1
ID.6	ID.5	ID.4	ID.3	ID.2	ID.1	ID.0
1	0	0	0	1	1	0

Example:

For example, this results in the node address 46<sub>h</sub> (70<sub>d</sub> or 01000110<sub>b</sub>)

## 10.4 LSS

The RESISTRON<sup>®</sup> Temperature Controller RES-5009 supports the CANopen Layer Setting Services (LSS). LSS can be used to assign a CANopen node address to an unconfigured device. It is also possible to set the CAN baud rate by using LSS.

CANopen defines two mechanisms by which an LSS master can detect unconfigured LSS slaves: „Fastscan service“ and „Identify remote slave service“. The RESISTRON<sup>®</sup> Temperature Controller RES-5009 only supports „Fastscan service“, as recommended by the CiA.

If an RESISTRON<sup>®</sup> Temperature Controller RES-5009 is to be configured via LSS, all DIP switches for setting the baud rate and CANopen node address must be set to “off”. In this state, the automatic baud rate detection "AutoBaud" is active and the unit is waiting for the assignment of a CANopen node address via LSS. The mechanisms for assigning a CANopen node address are described in specification CiA 305 “Layer setting services (LSS) and protocols” version 3.0.0.

The following points must be observed:

- By means of the LSS command “store configuration service”, the baud rate and node address can be stored retentively. The “pending baud rate” and “pending node ID” are saved as “persistent baud rate” and “persistent node ID”. As described in CiA 305, these are not necessarily the currently active values.
- If the “persistent baud rate” and “persistent node ID” in the device contain valid values, these will be used when restarting. In this case, the device is immediately ready for communication via CANopen without having to wait for the assignment of a CANopen node address.
- If the DIP switches of baud rate or node address are set to a value other than 0 when the device is restarted, the retentively stored values for baud rate and CANopen node address will be deleted. This can be used, for example, in the event of a misconfiguration if CANopen node addresses are assigned twice in the network.
- If the DIP switches of baud rate and CANopen node address are set to values other than 0, LSS services will still be processed by the device. Thus, the baud rate or CANopen node address can be set via LSS command even in this state. After a restart, however, the persistent values will be deleted again.

## 10.5 CANopen<sup>®</sup> LEDs

The RESISTRON<sup>®</sup> Temperature Controller RES-5009 has two CANopen-specific LEDs. The red CANopen error LED and the green CANopen run LED are implemented according to specification CiA 303/3. (↪ section 8.2 "Device configuration" on page 21).

The blinking codes of the red error LED have the following meaning:

Error LED (ERR)	State	Description
Off	No error	The device has not detected any CANopen-specific errors and is operating normally.
Flickering (10 Hz)	AutoBaud / LSS	automatic baud rate detection “AutoBaud” or Layer Setting Services “LSS” is active (Alternate flickering with the Run LED)
Blinking (2.5 Hz)	Invalid configuration	The configuration, e. g. of the node address, is faulty.
Single flash	CAN warning level reached	At least one CAN error counter has reached or exceeded the warning level.

Error LED (ERR)	State	Description
Double flash	Error event	A heartbeat error has been detected (heartbeat consumer).
On	Bus off	The CAN controller is in the bus off state.

The blinking codes of the green run LED have the following meaning:

Run LED (RUN)	State	Description
Flickering (10 Hz)	AutoBaud / LSS	automatic baud rate detection "AutoBaud" or Layer Setting Services "LSS" is active (Alternate flickering with the error LED)
Blinking (2.5 Hz)	Pre operational	The device is in the "Pre operational" state
Single flash	Stopped	The device is in the "Stopped" state
On	Operational	The device is in the "Operational" state

## 10.6 Heartbeat

### 10.6.1 Producer heartbeat

The RESISTRON<sup>®</sup> Temperature Controller RES-5009 does not generate heartbeat messages by default. With the help of CANopen object 1017<sub>h</sub>, the producer heartbeat can be set project-specifically.



#### CAUTION

The use of the producer heartbeat is strongly recommended. The producer heartbeat should be monitored in the CANopen master. With this mechanism, an interruption in communication with the RESISTRON<sup>®</sup> Temperature Controller RES-5009 can be quickly detected by the CANopen master.

When a new heartbeat time is set using object 1017<sub>h</sub>, the corresponding counter is restarted. The next heartbeat message is sent after the configured time after setting the object. Therefore, a longer time interval between two heartbeat messages can occur once in the heartbeat configuration.

### 10.6.2 Consumer heartbeat

The RESISTRON<sup>®</sup> Temperature Controller RES-5009 can monitor heartbeats of up to 4 CANopen nodes. The configuration is carried out via CANopen object 1016<sub>h</sub>, sub index 1 to 4. By default, heartbeat monitoring is not active. If a heartbeat error is detected, a currently active welding process is interrupted and the device is put into the PreOperational state. In addition, an emergency message is sent.



#### CAUTION

It is strongly recommended to configure the monitoring of the consumer heartbeats project-specifically in the RESISTRON<sup>®</sup> Temperature Controller RES-5009. In case of CANopen communication problems, an uncontrolled welding process can thus be avoided.

## 10.7 Object directory

In addition to the information included in this chapter, further information on the individual CANopen objects can also be obtained from the EDS file (↪ section 10.1 "Electronic Data Sheet (EDS)" on page 58).

### 10.7.1 CANopen standard objects

The RESISTRON<sup>®</sup> Temperature Controller RES-5009 supports the following CANopen standard objects. The CANopen standard objects are described in more detail in specification CiA 301.



#### CAUTION

The change of values of the listed objects through write access is temporary. When the device is restarted, the values must be written again by the CANopen master.

Index	Name	Access	Standard value	Range of values	Data type
1000 <sub>h</sub>	Device type	RO	0x00000000 → No CAN-open standard profile	-	UINT32
1001 <sub>h</sub>	Error register	RO	-	-	UNIT8
1002 <sub>h</sub>	Manufacturer status register (↪ section 10.7.8 "Manufacturer Status Register 1002 <sub>h</sub> " on page 70)	RO	-	-	UINT32
1003 <sub>h</sub>	Pre-defined error field SubIndex 0: Number of errors	RW	-	-	UINT8
	SubIndex 1...16: Error entries (↪ section 10.7.9 "PreDefined Error Field 1003 <sub>h</sub> " on page 71)	RO	-	-	UINT32
1005 <sub>h</sub>	COB-ID SYNC Defines the COB-ID for the SYNC message. This can be changed. Bit 30 must always be 0, as the RESISTRON <sup>®</sup> Temperature Controller RES-5009 cannot generate a SYNC message.	RW	0x00000080	-	UINT32
1008 <sub>h</sub>	Manufacturer Device Name (device name)	RO	"RES-5009"	-	STRING
100A <sub>h</sub>	Manufacturer software version Software version of the RESISTRON <sup>®</sup> Temperature Controller RES-5009, e. g. 5009.00.300	RO	-	-	STRING
1010 <sub>h</sub>	Store parameters (↪ section 10.10 "Store and restore functionality" on page 73)				
	SubIndex 1: Save all parameters	RW	0x00000001	-	UINT32
	SubIndex 4: Save manufacturer defined parameters	RW	0x00000001	-	UINT32

Index	Name	Access	Standard value	Range of values	Data type
1011 <sub>h</sub>	Restore default parameters (↪ section 10.10 "Store and restore functionality" on page 73)				
	SubIndex 1: Restore all default parameters	RW	0x00000001	-	UINT32
	SubIndex 4: Restore manufacturer defined default parameters	RW	0x00000001	-	UINT32
1012 <sub>h</sub>	COB-ID time stamp Defines the COB ID, which can be used for the TIME service to set time and date. Bit 30 must always be 0, as the RESISTRON® Temperature Controller RES-5009 cannot generate a TIME message.	RW	0x80000100 → TIME is consumed with COB ID 0x100.	-	UINT32
1014 <sub>h</sub>	COB-ID EMCY Defines the COB ID with which emergency messages are sent. → With bit 31 on low, the emergency messages are switched on. → With bit 31 on high, the emergency messages are switched off. Here, the current COB ID plus bit 31 must be written. Before changing the COB ID EMCY, the emergency messages must be switched off by means of bit 31.	RW	0x80 <sub>h</sub> + node ID  Emergency messages switched on with standard ID	-	UINT32
1015 <sub>h</sub>	Inhibit time EMCY Inhibit time for generated emergency messages in 100 µs resolution.	RW	0	0...65535 (0 ... 6.5535 s)	UINT16
1016 <sub>h</sub>	Consumer Heartbeat Time 1...4 (↪ section 10.6.2 "Consumer heartbeat" on page 62)	RW	0x00000000 → Not active	-	UINT32
1017 <sub>h</sub>	Producer Heartbeat Time (↪ section 10.6.1 "Producer heartbeat" on page 62)	RW	0x0000 → Not active	0 ... 65565 ms	UINT16
1018 <sub>h</sub>	Identity Object				
	Sub index 1: Vendor ID	RO	0x00000576 → „ROPEX Industrie-Elektronik GmbH“	-	UINT32
	Sub index 2: Product code	RO	209 <sub>d</sub>		UINT32
	Sub index 3: Revision number	RO	-	-	UINT32
	Sub index 4: Serial number	RO	-	-	UINT32

Index	Name	Access	Standard value	Range of values	Data type
1400 <sub>h</sub>	Receive PDO communication parameter				
1600 <sub>h</sub>	Receive PDO mapping parameter				
1800 <sub>h</sub>	Transmit PDO communication parameter				
1A00 <sub>h</sub>	Transmit PDO mapping parameter				

↗ Specification CiA 301  
↗ section 10.8 "PDO mapping" on page 71

### 10.7.2 Parameter data



#### CAUTION

The change of values of the listed objects through write access is temporary. A retentive storage of the values can be achieved via the store and restore mechanism (↗ section 10.10 "Store and restore functionality" on page 73).

Index	Name	Access	Standard value	Range of values	Data type
4000 <sub>h</sub>	Temperature range / alloy (↗ section 10.14 "Temperature range and alloy" on page 74)	RW	10	0, 1, 4, 5, 8, 9, 10, 11	UINT8
4001 <sub>h</sub>	Lower temperature o.k. threshold	RW	10 K	3 ... 99 K	UINT8
4002 <sub>h</sub>	Upper temperature o.k. threshold	RW	10 K	3 ... 99 K	UINT8
4003 <sub>h</sub>	Calibration temperature Sub index 1: Channel 0 ... Sub index 8: Channel 7	RW	20 °C	-1, 0...40 °C -1 → variable	INT8
4004 <sub>h</sub>	Heating time limit (100 ms units)	RW	0	0 ... 999 (0 ... 99.9 s)	UINT16
4006 <sub>h</sub>	Measurement impulse duration	RW	17	17...30 (1.7...3.0 ms)	UINT8
400A <sub>h</sub>	Temperature coefficient Sub index 1: Channel 0 ... Sub index 8: Channel 7	RW	1100 ppm/K	400...4000 ppm/K	UINT16
400B <sub>h</sub>	Temperature range	RW	1 (300 °C)	0 (200 °C), 1 (300 °C), 2 (400 °C), 3 (500 °C)	UINT8
400C <sub>h</sub>	Maximum temperature	RW	300 °C	200...500 °C	UINT16

Index	Name	Access	Standard value	Range of values	Data type
400D <sub>h</sub>	Temperature diagnosis	RW	0 (off)	0 (off), 1 (on)	UINT8
400E <sub>h</sub>	Temperature diagnosis delay (100 ms units)	RW	0 s	0...99 (0...9.9 s)	UINT8
400F <sub>h</sub>	Heat-up time monitoring (100 ms units)	RW	0 s	0...999 (0...99.9 s)	UINT16
4010 <sub>h</sub>	AUTOCOMP	RW	0 (off)	0 (off), 1 (on), 2 (automatic)	UINT8
4011 <sub>h</sub>	Temperature OK bit	RW	1 (active when ACTUAL=SET POINT)	0 (off), 1 (active when ACTUAL=SET- POINT) 2 (active when ACTUAL=SET- POINT with latch)	UINT8
4012 <sub>h</sub>	Hold mode	RW	0 (off)	0 (off), 1 (on), 2 (2 seconds)	UINT8
4013 <sub>h</sub>	Start retrigger timeout (↪ section 10.11 "START command" on page 73)	RW	2500ms	10...5000 ms	UINT16
4014 <sub>h</sub>	Start-up delay after reset	RW	0.20 s	0...999 (0...9.99 s)	UINT16
4015 <sub>h</sub>	Maximum measurement pause [periods]	RW	10	0...10	UINT8

### 10.7.3 Input data

**CAUTION**

In case of write access, the input data are only stored temporarily. When the device is restarted, the input values must be written again.

Index	Name	Access	Standard value	Range of values	Data type
4100 <sub>h</sub>	Setpoint value / AC temperature				
	Sub index 1: Setpoint for CANopen START signal and START 0 (24 VDC)	RW	-	0...300 °C / 500 °C	UINT16
	Sub index 2: Setpoint for START 1 (24 VDC)	RW	-	0...300 °C / 500 °C	UINT16
4101 <sub>h</sub>	Control (↪ section 10.7.6 "Control information" on page 69)	RW			UINT16

### 10.7.4 Output data

Index	Name	Access	Standard value	Range of values	Data type
4200 <sub>h</sub>	Actual temperature	RO	-	-99...999 °C	INT16
4201 <sub>h</sub>	Start temperature	RO	-99	-99...999 °C	INT16
4202 <sub>h</sub>	Device temperature	RO	-	-60...190 °C	INT16
4203 <sub>h</sub>	Status (↪ section 10.7.7 "Status information" on page 70)	RO			UINT16
4204 <sub>h</sub>	Error number (↪ section 9.15 "Error messages" on page 51)	RO	-	-	UINT16

### 10.7.5 Runtime data



#### CAUTION

In case of write access, the runtime data are directly stored retentively. When the device is restarted, the runtime data are retained.

Index	Name	Access	Standard value	Range of values	Data type
4300 <sub>h</sub>	System date (↪ section 10.17 "Date and time in CAN-open" on page 75)	RW	-	-	UINT32
4301 <sub>h</sub>	System time (↪ section 10.17 "Date and time in CAN-open" on page 75)	RW	-	-	UINT32
4302 <sub>h</sub>	Operating hours (in 0.1 h)	RO	0 (0.0 h)	0...999999999 (0...99999999.9 h)	UINT32
4303 <sub>h</sub>	non-resettable total cycles counter	RO	0	0...999999999	UINT32
4304 <sub>h</sub>	Resettable total cycles counter	RW	0	0...999999999	UINT32
4305 <sub>h</sub>	Cycle counter Sub index 1: Channel 0 ... Sub index 8: Channel 7	RW	0	0...999999999	UINT32

Index	Name	Access	Standard value	Range of values	Data type
4306 <sub>h</sub>	Calibration data deviation Sub index 1: Channel 0 ... Sub index 8: Channel 7	RO	0	-10000...10000 (-100.00%...100.00%)	INT16
4307 <sub>h</sub>	Number of windings through the current transformer	RW	1	1...9	UINT8
4308 <sub>h</sub>	Calibration resistance Sub index 1: Channel 0 ... Sub index 8: Channel 7	RO	-	0...65535 (0...6553.5 mOhm)	UINT16
4309 <sub>h</sub>	Initial calibration resistance (after master AUTOCAL) Sub index 1: Channel 0 ... Sub index 8: Channel 7	RO	-	0...65535 (0...6553.5 mOhm)	UINT16
430A <sub>h</sub>	TCR calculator (↪ section 10.15 "TCR calculator" on page 74)				
	Sub index 1: Externally measured temperature	RW	40	40...600 °C	UINT16
	Sub index 2: Calculated temperature coefficient	R	0	400...4000 ppm/K 0 (error), 65535 (error)	UINT16

### 10.7.6 Control information

The "Control" object 4101<sub>h</sub>/00 contains various bit-coded control information, which can be used to control the RESISTRON<sup>®</sup> Temperature Controller RES-5009:

Name:	Reserve					Selected channel			Reserve			Control function				
	0	0	0	0	0	CH2	CH1	CH0	0	0	0	MA	MP	RS	ST	AC
Bit no.:	15	14	13	12	11	10	9	8	7	6	5	4	3	2	1	0

Bit	Meaning
CH0 ...CH2	Channel selection
MA	Master AUTOCAL
MP	Measurement pause
RS	Reset
ST	Start
AC	AUTOCAL

The meaning of the bits is described in ↗ section 9.2 "Input data" on page 30.

### 10.7.7 Status information

The "Status" object 4203<sub>h</sub>/00 contains various bit-coded information, which reflect the status of the RESISTRON<sup>®</sup> Temperature Controller RES-5009:

	Reserve				Active channel			Status information								
Name:	0	0	0	MU	CH2	CH1	CH0	SA	IA	WA	AA	AG	AL	TE	TO	RA
Bit no.:	15	14	13	12	11	10	9	8	7	6	5	4	3	2	1	0

Bit	Meaning
MU	Measurement interruption
CH0...CH2	active channel
SA	Standby active
IA	Information active
WA	Warning active
AA	AUTOCAL active
AG	AUTOCAL blocked
AL	Alarm active
TE	Temperature reached
TO	Temperature OK
RA	Control active

The meaning of the bits is described in ↗ section 9.3 "Output data" on page 35.

### 10.7.8 Manufacturer Status Register 1002<sub>h</sub>

In the Manufacturer Status Register (CANopen object 1002<sub>h</sub>), the status of the RESISTRON<sup>®</sup> Temperature Controller RES-5009 can be read out. The 32 bit value is a combination of ROPEX error number (object 4203<sub>h</sub>, ↗ section 9.15 "Error messages" on page 51) and status information (4204<sub>h</sub>, ↗ section 10.7.7 "Status information" on page 70).

	ROPEX error number															
Name:	0	0	0	0	0	0	A9	A8	A7	A6	A5	A4	A3	A2	A1	A0
Bit no.:	31	30	29	28	27	26	25	24	23	22	21	20	19	18	17	16

	Reserve				Active channel			Status information								
Name:	0	0	0	MU	CH2	CH1	CH0	SA	IA	WA	AA	AG	AL	TE	TO	RA
Bit no.:	15	14	13	12	11	10	9	8	7	6	5	4	3	2	1	0

### 10.7.9 PreDefined Error Field 1003<sub>h</sub>

The RESISTRON<sup>®</sup> Temperature Controller RES-5009 supports the CANopen PreDefined Error Field Objekt 1003<sub>h</sub> with up to 16 entries. The 32 bit value is a combination of ROPEX error number (object 4203<sub>h</sub>, ↪ section 9.15 "Error messages" on page 51) and CANopen error code (↪ CiA 301 specification).

ROPEX error number																
Name:	0	0	0	0	0	0	A9	A8	A7	A6	A5	A4	A3	A2	A1	A0
Bit no.:	31	30	29	28	27	26	25	24	23	22	21	20	19	18	17	16

CANopen error code																
Name:	E15	E14	E13	E12	E11	E10	E9	E8	E7	E6	E5	E4	E3	E2	E1	E0
Bit no.:	15	14	13	12	11	10	9	8	7	6	5	4	3	2	1	0

When generating emergency messages (↪ section 10.9 "Emergency messages" on page 72) the errors are automatically entered into the PreDefined error field. Sub index 1 always contains the most recently detected error, followed by the older errors. If there are more than 16 errors, the oldest errors will be overwritten. By writing the value 0 to sub index 0, the list can be deleted.

## 10.8 PDO mapping

The RESISTRON<sup>®</sup> Temperature Controller RES-5009 supports one Rx and one Tx PDO each. With this cyclical communication, the controller can be controlled or the current status can be determined. PDO mapping is fixed and cannot be changed. The PDO communication parameters can be adjusted as required by means of the CANopen objects 1400<sub>h</sub>/00 or 1800<sub>h</sub>/00 (↪ CiA 301 specification). The default values can be taken from the EDS file (↪ section 10.1 "Electronic Data Sheet (EDS)" on page 58).

As generally intended by CANopen, the Rx and Tx PDOs are only active in the "Operational" state.

### 10.8.1 Rx PDO







The Rx PDO (CANopen master → RESISTRON<sup>®</sup> Temperature Controller RES-5009; COB ID: 0x200 + NODE ID) contains the following mapped elements:

CanByte	0	1	2	3	4	5
Object	Setpoint 0		Control		Setpoint 1	
Index	4100 <sub>h</sub>		4101 <sub>h</sub>		4100 <sub>h</sub>	
Sub index	01 <sub>h</sub>		00 <sub>h</sub>		02 <sub>h</sub>	

By default, the transmission type mode "event driven" is set for the Rx PDO (object 1400<sub>h</sub>/02). This means that the contained values are processed immediately upon receipt of the PDOs. If necessary, the transmission type can be changed to "synchronous".

The event timer (object 1400<sub>h</sub>/05) is active by default so that an emergency message is generated when an RPDO timeout is detected.

## 10.8.2 Tx PDO

The Tx PDO (RESISTRON<sup>®</sup> Temperature Controller RES-5009 →        master ; COB ID: 0x180 + NODE ID) contains the following mapped elements:



CanByte	0	1	2	3	4	5	6	7
Object	Actual temperature		Status		Error number		Start temperature	
Index	4200 <sub>h</sub>		4203 <sub>h</sub>		4204 <sub>h</sub>		4201 <sub>h</sub>	
Sub index	00 <sub>h</sub>		00 <sub>h</sub>		00 <sub>h</sub>		00 <sub>h</sub>	

By default, the transmission type mode “event driven” is set for the Tx PDO (object 1800<sub>h</sub>/02). This means that the PDO is sent in a defined time grid. The grid is specified by the event timer value and can be adapted to suit the project (object 1800<sub>h</sub>/05). If necessary, the transmission type can be changed to “synchronous”.

Depending on the type and number of CAN bus participants, it is necessary to adjust the Tx PDO timing when using lower CAN baud rates. This avoids excessive CAN bus load in case of many bus participants. If required, the Tx PDO event timer value can be increased. The transmission grid increases, and the bus load decreases.

## 10.9 Emergency messages

The RESISTRON<sup>®</sup> Temperature Controller RES-5009 sends CANopen emergency messages when errors are detected. The first three bytes of the CAN message contain the error code and the error register according to the  CiA 301 specification. The last five bytes are manufacturer-specific.

Byte	Content	Description	
0	CANopen specific error code	 CiA 301 specification	
1			
2	CANopen error register	 CiA 301 specification Current value from CANopen object 1001 <sub>h</sub>	
3	Manufacturer specific error code	CAN error status	
		0	CAN controller is in stopped mode
		1	CAN controller is in sleep mode
		2	CAN controller is active
		3	CAN controller is active, warning level of error counters has been reached
		4	CAN controller is in passive mode
		5	CAN controller is in bus off state
		10	General error of CAN hardware
4	Manufacturer specific error code	CAN Receive Error Counter	
5	Manufacturer specific error code	CAN Transmit Error Counter	

Byte	Content	Description
6	Manufacturer specific error code	ROPEX error code (LSB) ↳ section 9.15 "Error messages" on page 51
7	Manufacturer specific error code	ROPEX error code (MSB) ↳ section 9.15 "Error messages" on page 51

## 10.10 Store and restore functionality

By means of the CANopen objects 1010<sub>h</sub> (store parameters) and 1011<sub>h</sub> (restore default parameters), the parameter data set by means of CANopen (↳ section 10.7.2 "Parameter data" on page 65) can be stored or restored retentively.

The following commands are supported:

- 1010<sub>h</sub>/01<sub>h</sub>: Save all parameters
- 1010<sub>h</sub>/04<sub>h</sub>: Save manufacturer defined parameters
- 1011<sub>h</sub>/01<sub>h</sub>: Restore all default parameters
- 1011<sub>h</sub>/04<sub>h</sub>: Restore manufacturer defined default parameters

The following manufacturer-specific CANopen elements are saved or restored. 'All parameters' and 'manufacturer defined parameters' handle the same elements.

4000<sub>h</sub>, 4001<sub>h</sub>, 4002<sub>h</sub>, 4003<sub>h</sub>, 4004<sub>h</sub>, 4006<sub>h</sub>, 400A<sub>h</sub>, 400B<sub>h</sub>, 400C<sub>h</sub>, 400D<sub>h</sub>, 400E<sub>h</sub>, 400F<sub>h</sub>, 4010<sub>h</sub>, 4011<sub>h</sub>, 4012<sub>h</sub>, 4013<sub>h</sub>, 4014<sub>h</sub> and 4015<sub>h</sub>. Thus, no communication-specific CANopen parameters are stored and restored.

For saving the elements, the value 0x65766173 ("save") must be written into the CANopen object 1010<sub>h</sub>/xx.

For loading the default values, the value 0x64616F6C ("load") must be written into the CANopen object 1011<sub>h</sub>/xx.

After a "Restore default parameters" service, the default values are not active until a node reset service has additionally been executed, or a device restart has been carried out.

The saved CANopen object values are used as default values when the device is restarted.

## 10.11 START command

A START request (ST bit) is only accepted if there is no alarm and the AUTOCAL function is not executed. To avoid uncontrolled heating in case of CAN communication problems, a START request (ST bit) must be sent cyclically. The cyclic setting of the START request (ST bit) can be done either by SDO or by PDO.

The maximum cycle time for a START request can be set. The corresponding timeout is defined in CANopen object 4013<sub>h</sub>/00<sub>h</sub> ("Start retrigger timeout [ms]"). After the timeout has elapsed without the START request being resent, the controller automatically terminates the heating phase and switches to measurement mode. The value of "Start retrigger timeout" can be adjusted to the project's frame conditions. For security reasons, it is not possible to switch off the timeout.

## 10.12 Heating time limit

The heating time limit can be used to activate additional monitoring against unwanted continuous heating. If the start bit should remain set longer than the time set by the heating time limit, then the RESISTRON<sup>®</sup> Temperature Controller RES-5009 automatically switches off the heating impulse after the set heating time limit has expired. The start bit must be reset before the controller is restarted.

The heating time limit is switched off as standard (value 0) and can be selected between 0 s and 99.9 s (0 and 999).

### 10.13 Master AUTOCAL (MA)

Setting the master AUTOCAL request (MA bit) starts the calibration process as in section 9.2.1 "AUTOCAL (AC) automatic zero calibration" on page 30. But in addition, after successful performance of the Master AUTOCAL function, the heating element resistance determined by the controller is stored as a reference value, e. g. after a heating element replacement.

This reference value is used as the basis for calculating the calibration value deviation in subsequent calibration processes (started by AUTOCAL request). The calibration value deviation can be used to evaluate the ageing of the heating element.

### 10.14 Temperature range and alloy

Parameter object 4000<sub>h</sub> can be used to select both the temperature range and the heating element alloy. By changing the standard value (10), the setting of the rotary coding switch (↪ section 8.2.2 "Configuration of the rotary coding switch for temperature range and alloy" on page 22) can be overwritten.

Value	Temperature range	Alloy
0	300 °C	TCR = 1100 ppm/K, e.g. Alloy 20
1	300 °C	TCR = 780 ppm/K, e.g. Alloy L
4	500 °C	TCR = 1100 ppm/K, e.g. Alloy 20
5	500 °C	TCR = 780 ppm/K, e.g. Alloy L
8	300 °C	TCR = 3500 ppm/K, e. g. NOREX
9	Setting over PC visualisation	Setting over PC visualisation
10	Setting of the rotary coding switch	Setting of the rotary coding switch
11	Variable: Value from CANopen object 400B <sub>h</sub> is used.	Variable: Value from CANopen object 400A <sub>h</sub> is used.

With setting 11, the value stored under CANopen object 400B<sub>h</sub> is applied for the temperature range. For the alloy, the value stored under CANopen object 400A<sub>h</sub> for the active channel is applied.

After changing the parameters "Temperature range/alloy", "Temperature range" or "Temperature coefficient", the AUTOCAL function must be executed.

### 10.15 TCR calculator

The TCR calculator can be used to determine the temperature coefficient (TCR) of the heating element used. The real temperature coefficient of the heating element often deviates from the standard value. The material composition and the processing influence the properties of the heating element. This causes the temperature display of the controller to deviate from the real temperature of the heating element. The use of the TCR calculator allows a simple correction of the TCR value and thus a better match between the temperature display of the controller and the real temperature of the heating element.

1. Measuring the real temperature: To calculate the TCR value, the temperature at the heating element is measured in control mode (ST bit = 1) using an external temperature sensor (e. g. a thermocouple).
2. Sending the measured temperature to the temperature controller: The measured temperature is transmitted to the temperature controller in CANopen object 0x430A/01.
3. On the basis of these data, the temperature controller calculates a temperature coefficient.

4. Using the calculated temperature coefficient: The calculated temperature coefficient can be read out and used from CANopen object 0x430A/02. The temperature coefficient is only calculated in control mode (ST bit = 1). Reading back the calculated TCR value must take place during active control operation, i. e. during an active heating pulse, as the internal measured value of the current heating element temperature is used for the calculation. Errors in the calculation of the temperature coefficient are reported with the value 0 (calculated temperature coefficient too low or no active control mode) or 65535 (calculated temperature coefficient too high). To use the calculated TCR value, it must be set for the corresponding channel as temperature coefficient in object 0x400A (temperature coefficient). In addition, the value 11 (variable) must be used in object 0x4000 (alloy/temperature range).



### NOTE

Only very thin sensors must be used for temperature measurement, e. g. ROPEX temperature sensor TS-2. Thicker sensors, e. g. a PT-100, must not be used. This ensures that the thermodynamic conditions remain constant when closing the welding tools and that the heating elements are not damaged.

## 10.16 Signals START 0 and START 1

The setpoints for the 24 VDC start signals are set via the following CANopen objects.

- START 0: Setpoint setting in object 4100<sub>h</sub>/01 ("setpoint 0 [°C]")
- START 1: Setpoint specification in object 4100<sub>h</sub>/02 ("setpoint 1 [°C]")

The values are not stored retentively and must be initialised again after a restart of the device.

## 10.17 Date and time in CANopen

The date of the internal clock is represented in CANopen object 4300<sub>h</sub>/00 ("System Date"). During writing, the date is checked for plausibility. If the date is invalid, writing will be refused. The 32 bit value has the following structure:

Element	Year (high byte)	Year (low byte)	Month	Day
Range of values:	2000 ... 2099		1 ... 12	1 ... 31
Bit no.:	31 ... 24	23 ... 16	15 ... 8	7 ... 0

The time of the internal clock is represented in CANopen object 4301<sub>h</sub>/00 ("System Time"). During writing, the time is checked for plausibility. If the time is invalid, writing will be refused. The 32 bit value has the following structure:

Element	Hours	Minutes	Seconds	Milliseconds (not used) <sup>1</sup>
Range of values:	0 ... 23	0 ... 59	0 ... 59	0 ... 99
Bit no.:	31 ... 24	23 ... 16	15 ... 8	7 ... 0

1. Milliseconds are not supported by the internal clock. A read access always returns 0. When writing, a value in the range 0...99 must be transmitted, otherwise the RESISTRON<sup>®</sup> Temperature Controller RES-5009 responds with the error "invalid value".

## 10.18 CANopen Time stamp object

The RESISTRON<sup>®</sup> Temperature Controller RES-5009 supports the CANopen time stamp object as consumer. It can be used by the CANopen master to distribute the current time and date in the network. When the time stamp object is received by the controller, the time and date of the internal clock are automatically set. If errors are detected during the plausibility check, the internal clock will not be changed.

CANopen object 1012<sub>h</sub> (“COB ID Time Stamp”) can be used to set the receive identifier for the time stamp message. By default, the COB ID Time Stamp is set to the value 100<sub>h</sub> (CANopen default value).

The time stamp object is only processed when the controller is in the “Operational” state. In other CANopen states, a received time stamp object will be ignored.

## 10.19 CANopen states

The functionality of the RESISTRON<sup>®</sup> Temperature Controller RES-5009 depends, among other things, on the current CANopen status.

If the RESISTRON<sup>®</sup> Temperature Controller RES-5009 is

### in “Pre-Operational” state

- the measurement pause is automatically active
- no measurement impulses are generated
- the current temperature of the heating band is not measured.
- the AUTOCAL/Master-AUTOCAL function cannot be executed.

### in “Operational” state

- normal controller operation incl. temperature measurement is ensured
- cyclic communication by means of PDOs is possible.

## 10.20 Transmission of multi-byte elements with CANopen

The CANopen specification prescribes how multi-byte elements must be transmitted. In these cases, the least significant byte is always transmitted to CAN first. This is known as little-endian or INTEL format. Example:

Value to be transmitted: 0x11223344

- Byte n+0 of the transmission: 0x44
- Byte n+1 of the transmission: 0x33
- Byte n+2 of the transmission: 0x22
- Byte n+3 of the transmission: 0x11

## 10.21 CANopen Timing values

The CANopen software is processed internally with a time grid of 2 ms. Therefore, timings can only be configured with a resolution of 2 ms. If timings are set to odd values via CANopen, the values are rounded internally in the software. The objects that can be read out via CANopen contain the rounded, active timing values. Thus, the written value may differ slightly from the read value.

## 11 ROPEX CAN



### CAUTION

The following descriptions contain only device-specific functions. Please consult your PLC description for general information on the CAN bus and system configuration.

### 11.1 Setting the baud rate

For the operation of the RESISTRON<sup>®</sup> Temperature Controller RES-5009, the CAN baud rate must be set correctly. The baud rate depends on the CAN bus network into which the controller is to be integrated.

The baud rate is set by means of four "BAUDRATE" DIP switches. The switches are read in once when the device is started. It is not possible to change the baud rate during operation.

Baud rate	DIP 3	DIP 4	DIP 5	DIP 6
1 MBaud	ON	-	-	-
800 kBaud	-	ON	-	-
500 kBaud	ON	ON	-	-
250 kBaud	-	-	ON	-
205 kBaud	ON	-	ON	-
125 kBaud	-	ON	ON	-
100 kBaud	ON	ON	ON	-
50 kBaud	-	-	-	ON
20 kBaud	ON	-	-	ON
10 kBaud	-	ON	-	ON
AutoBaud	-	-	-	-

The switch position '-' means off.

"AutoBaud" is active for all switch combinations not listed.

The automatic baud rate detection "AutoBaud" only works if the controller is in a CAN network in which at least two participants are already exchanging valid CAN messages.

As long as the correct baud rate has not been detected, the controller behaves passively on the CAN bus and does not influence the existing communication.

The controller can only detect the baud rates listed above, other baud rates cannot be detected.



### CAUTION

If the baud rate in the CAN network is changed during operation, the controller must be switched off and on again so that the "AutoBaud" function is active again.



### CAUTION

When baud rate detection "AutoBaud" is active, the ERR LED (red) and RUN LED (green) flicker alternately.

### 11.2 Setting the CAN identifier

The 8-pin DIP switch “IDENTIFIER / NODE ID” determines the most significant 8 bits of the 11 bit long standard CAN identifier. The least significant 3 bits are fixed. Since the identifier 0 should not be used, a maximum of 255 different controllers can thus be addressed in a CAN network.

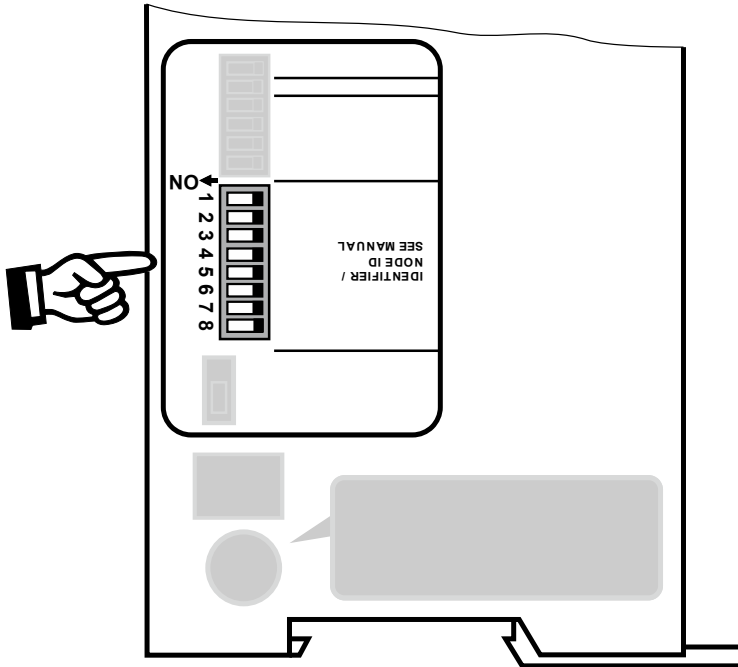

For the reception of CAN messages, the least significant identifier bit is fixed at 0.

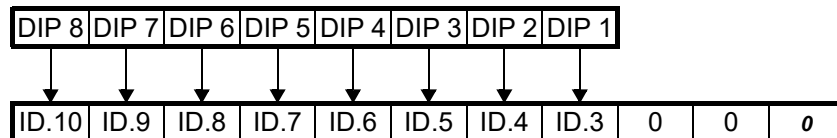

For sending CAN messages, the least significant bit is fixed at 1. The CAN messages sent by the RESISTRON<sup>®</sup> Temperature Controller RES-5009 therefore always have an identifier one higher than the received CAN messages.

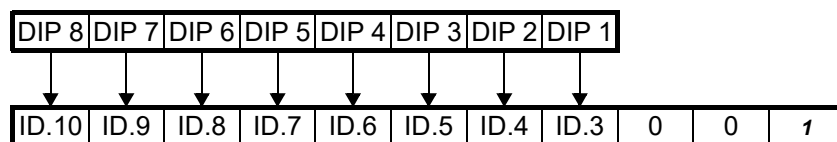

### 11.3 ROPEX CAN LEDs

In ROPEX CAN operation, the ERR LED (red) and RUN LED (green) have the following meaning.

Error LED (ERR)	State	Description
Off	No error	The device has not detected any CAN-specific errors and is operating normally.

Error LED (ERR)	State	Description
Flickering (10 Hz)	AutoBaud	automatic baud rate detection "AutoBaud" is active (Alternate flickering with the Run LED)
Single flash	CAN warning level reached	At least one CAN error counter has reached or exceeded the warning level (too many error frames).
On	Bus off	The CAN controller is in the bus off state.

Run LED (RUN)	State	Description
Flickering (10 Hz)	AutoBaud	automatic baud rate detection "AutoBaud" is active (Alternate flickering with the ERR LED)
On	Ready for operation	The CAN controller is ready for operation.
Brief turning off and on again of the LED	Communication	A CAN message has been received or sent.

## 11.4 ROPEX CAN protocol

The CAN messages of the RESISTRON<sup>®</sup> Temperature Controller RES-5009 are basically composed of 4 bytes. The first two bytes form a 16-bit address, the last two a 16-bit value:

Address.H	Address.L	Value.H	Value.L
Byte 1	Byte 2	Byte 3	Byte 4

"Address.H" is the first byte transmitted, "Value.L" is transmitted last.

## 11.5 Receiving CAN messages

The following table shows the complete command range of the RESISTRON<sup>®</sup> Temperature Controller RES-5009 when receiving CAN messages:

Address (hex)	Value (dec.)	Meaning
0000	0...T <sub>max</sub>	Save setpoint 0 (in °C)
0001	0...T <sub>max</sub>	Save setpoint 1 (in °C)
0002	0...T <sub>max</sub>	Save setpoint 2 (in °C)
0003	0...T <sub>max</sub>	Save setpoint 3 (in °C)
0100	0...T <sub>max</sub>	Overwrite setpoint 0 temporarily (in °C)
0101	0...T <sub>max</sub>	Overwrite setpoint 1 temporarily (in °C)
0102	0...T <sub>max</sub>	Overwrite setpoint 2 temporarily (in °C)
0103	0...T <sub>max</sub>	Overwrite setpoint 3 temporarily (in °C)

Address (hex)	Value (dec.)	Meaning
0004	0	Query setpoint 0 (in °C)
	1	Query setpoint 1 (in °C)
	2	Query setpoint 2 (in °C)
	3	Query setpoint 3 (in °C)
	4	Query the status of the controller
	5	Execute AUTOCAL function
	6	Execute RESET after alarm
	7	Query current actual value
	8	Query device number 1st part
	9	Query device number 2nd part
	10	Query calibration temperature channel 0
	11	Query current value of upper temperature monitoring (see value 22)
	12	Query current value of heating band alloy/temperature range
	13	Query current alarm and Autocal status
	14	Query currently set hold mode
	15	Query current AUTOCOMP status
	16	Query maximum setpoint
	17	Query current software revision
	18	Query current software variant (standard value: 00)
	19	Query variable temperature coefficient channel 0 (TCR in ppm/K)
	20	Query current configuration of temperature OK bit
	21	Query current value of lower temperature monitoring
	22	Query current value of upper temperature monitoring
	23	Query current configuration of temperature diagnosis
	24	Query current value of temperature diagnosis delay (in 0.1 s units)
	25	Query current configuration of heat-up time monitoring (in 0.1 s units)
	26	Query current value of measurement impulse length (in 0.1 ms units)
	27	Query current value of temperature range
	28	Query current device type
	256	preallocate temporary setpoint 0 with stored setpoint 0
	257	preallocate temporary setpoint 1 with stored setpoint 1
	258	preallocate temporary setpoint 2 with stored setpoint 2
	259	preallocate temporary setpoint 3 with stored setpoint 3
	30	Query status of internal clock
	31	Load current system time into temporary memory
	32	Transfer temporary memory to internal clock
33	Read seconds 'ss' from temporary memory	
34	Read hours 'hh' and minutes 'mm' from temporary memory	
35	Read month 'MM' and day 'DD' from temporary memory	
36	Read year 'YYYY' from temporary memory	

Address (hex)	Value (dec.)	Meaning
0004	37 38 39 40 41 42 43 44 45 46 47 48 49 50 80 81	Query calibration temperature channel 1 Query calibration temperature channel 2 Query calibration temperature channel 3 Query calibration temperature channel 4 Query calibration temperature channel 5 Query calibration temperature channel 6 Query calibration temperature channel 7 Query variable temperature coefficient channel 1 (TCR1 in ppm/K) Query variable temperature coefficient channel 2 (TCR2 in ppm/K) Query variable temperature coefficient channel 3 (TCR3 in ppm/K) Query variable temperature coefficient channel 4 (TCR4 in ppm/K) Query variable temperature coefficient channel 5 (TCR5 in ppm/K) Query variable temperature coefficient channel 6 (TCR6 in ppm/K) Query variable temperature coefficient channel 7 (TCR7 in ppm/K) Query CAN protocol version Query active channel
0005	Heating time and setpoint	START with specification of heating time and selection of setpoint Premature "STOP" when heating time = 0 (↪ section 11.5.2 "START/STOP command" on page 84)
0006	-1, 0...40	Save calibration temperature channel 0 (in °C); -1 → variable
0007	3...99	Save temperature monitoring (in K), changes lower and upper temperature monitoring limit simultaneously
0008	0 1 2 3 4 5 6 7 10 11 12 13 14 15	Save alloy/range (heating band alloy TCR/temperature range): TCR = 1100 ppm/K, temperature range max. 200 °C TCR = 1100 ppm/K, temperature range max. 300 °C TCR = 1100 ppm/K, temperature range max. 400 °C TCR = 1100 ppm/K, temperature range max. 500 °C TCR = 3500 ppm/K, temperature range max. 200 °C TCR = 3500 ppm/K, temperature range max. 300 °C TCR = 3500 ppm/K, temperature range max. 400 °C TCR = 3500 ppm/K, temperature range max. 500 °C Setting of rotary encoder switch applies (factory setting) TCR, temperature range, max. setpoint variable (see addresses 000A, 000B, 0014) TCR = 780 ppm/K, temperature range max. 200 °C TCR = 780 ppm/K, temperature range max. 300 °C TCR = 780 ppm/K, temperature range max. 400 °C TCR = 780 ppm/K, temperature range max. 500 °C
0009	0 1 2	Hold mode OFF Hold mode: ON Hold mode: 2 seconds (↪ section 9.4.9 "Hold mode" on page 43)
000A	400...4000	variable temperature coefficient (TCR in ppm/K), channel 0 (valid if the value 11 <sub>d</sub> was sent under address 0008)
000B	100...500	Maximum setpoint (in °C) (valid if the value 11 <sub>d</sub> was sent under address 0008)

Address (hex)	Value (dec.)	Meaning
000C	0 1 2	Temperature OK bit: OFF Temperature OK bit: ON when Setpoint = Actual Temperature OK bit: ON when Setpoint = Actual with latch function (☞ section 9.3.6 "Temperature OK (TO)" on page 35)
000D	3...99	Save lower temperature monitoring limit
000E	3...99	Save upper temperature monitoring limit
000F	0 1	Temperature diagnosis: OFF Temperature diagnosis: ON (☞ section 9.4.7 "Temperature diagnosis" on page 42)
0010	0...99	Temperature diagnosis delay in 0.1 s (☞ section 9.4.7 "Temperature diagnosis" on page 42)
0011	0...999	Heat-up time monitoring (0 = OFF) in 0.1 s (☞ section 9.4.8 "Heat-up time monitoring" on page 42)
0012	17...30	Measurement impulse length 0.1 ms (☞ section 9.4.5 "Measurement impulse duration" on page 40)
0013	0 1 2	AUTOCOMP: OFF AUTOCOMP: ON AUTOCOMP: AUTO (☞ section 9.4.6 "Automatic phase correction (AUTOCOMP)" on page 40)
0014	0 1 2 3	Temperature range 200 °C Temperature range 300 °C Temperature range 400 °C Temperature range 500 °C (valid if the value 11 <sub>d</sub> was sent under address 0008)
0016	0xhhmm hh={0...23} mm={0...59}	Write hours 'hh' and minutes 'mm' in temporary memory
0017	0xss00 ss={0...59}	Write seconds 'ss' in temporary memory
0018	0xJJJJ JJJJ={2000 ...2099}	Write year 'YYYY' in temporary memory
0019	0xMMDD MM={1..12} DD={1..31}	Write month 'MM' and day 'DD' in temporary memory 1->January, 2->February, ... 1->1st day of month, 2-> 2nd day of month, ...
001A	-1, 0...40	Save calibration temperature channel 1 (in °C); -1 → variable
001B	-1, 0...40	Save calibration temperature channel 2 (in °C); -1 → variable
001C	-1, 0...40	Save calibration temperature channel 3 (in °C); -1 → variable
001D	-1, 0...40	Save calibration temperature channel 4 (in °C); -1 → variable
001E	-1, 0...40	Save calibration temperature channel 5 (in °C); -1 → variable

Address (hex)	Value (dec.)	Meaning
001F	-1, 0...40	Save calibration temperature channel 6 (in °C); -1 → variable
0020	-1, 0...40	Save calibration temperature channel 7 (in °C); -1 → variable
0021	400...4000	variable temperature coefficient (TCR in ppm/K), channel 1 (valid if the value 11 <sub>d</sub> was sent under address 0008)
0022	400...4000	variable temperature coefficient (TCR in ppm/K), channel 2 (valid if the value 11 <sub>d</sub> was sent under address 0008)
0023	400...4000	variable temperature coefficient (TCR in ppm/K), channel 3 (valid if the value 11 <sub>d</sub> was sent under address 0008)
0024	400...4000	variable temperature coefficient (TCR in ppm/K), channel 4 (valid if the value 11 <sub>d</sub> was sent under address 0008)
0025	400...4000	variable temperature coefficient (TCR in ppm/K), channel 5 (valid if the value 11 <sub>d</sub> was sent under address 0008)
0026	400...4000	variable temperature coefficient (TCR in ppm/K), channel 6 (valid if the value 11 <sub>d</sub> was sent under address 0008)
0027	400...4000	variable temperature coefficient (TCR in ppm/K), channel 7 (valid if the value 11 <sub>d</sub> was sent under address 0008)
0050	0...255	Measurement pause with specified duration Ending the measurement pause when measurement pause duration = 0 (↪ section 9.2.4 "Measurement pause (MP)" on page 32)
0051	0...7	Channel selection (↪ section 9.2.5 "Channel selection (CH0...CH2)" on page 33)
F002	any	Factory setting of all parameters (↪ section 12 "Factory settings" on page 91)

### 11.5.1 Temperature setting (setpoint setting)

Up to four different setpoints can be permanently stored in the RESISTRON<sup>®</sup> Temperature Controller RES-5009. The stored setpoints are retained even after a power interruption. The setpoints can be read back on request. By programming the setpoints accordingly, it is possible, for example, to switch between pre-heat and main heat, or a certain setpoint can be reached slowly in different stages ("ramp"). The maximum settable setpoint  $T_{max}$  is determined by the selected temperature range (see CAN message address 0008 and CAN message address 0004, value 12). Here, temperature ranges of 200 °C, 300 °C, 400 °C and 500 °C can be defined.

Setpoints greater than  $T_{max}$  will be limited to  $T_{max}$  with subsequent storage. If "variable" is selected at alloy/range (CAN message address 0008) (value 11),  $T_{max}$  is determined by the selected temperature range (CAN message address 13<sub>h</sub>) and by the value stored at "maximum setpoint" (CAN message 000B).

The setpoint specification for the welding temperature must be greater than 40 °C. If it is smaller, no heat-up process will take place when the start/stop command is activated.

## 11.5.2 START/STOP command



### CAUTION

During the execution of the AUTOCAL function or when the RESET command is active, a START command or a “START” signal is not accepted (“HEAT” LED blinks quickly).

During a warning message with error no. 8...12 or 104...106, 111...114, 211, 302, 303, the alarm output is switched when a START command is activated (↪ section 9.15 "Error messages" on page 51). A heat-up process also does not take place here.

The parameter “value” in the START command (address 5) has the following structure:

Bit no.	Name	Meaning
Bit 0...7	Heating time	Time in 10 ms resolution until the control process is automatically switched off, at least 50 ms.
Bit 8 0...9	Setpoint	Number of the desired setpoint (0...3)
Bit 10 0...15	Unused	

START is only accepted if there is no alarm and the “AUTOCAL” function is not executed (↪ section 11.6.1 "Controller status" on page 89). Together with the START command, the number of the desired setpoint and the maximum heating time (50...2550 ms) are transmitted. If the RESISTRON<sup>®</sup> Temperature Controller RES-5009 is to heat for longer than 2550 ms (e. g. for permanent heating), a new START command must be sent before the heating time expires. This ensures that the controller does not heat uncontrollably for a long time in the absence of CAN communication. To end the heating phase prematurely, a START command with heating time < 5 (corresponding to < 50 ms) can be sent – the setpoint number is irrelevant. The controller then immediately ends the heating phase and switches to measurement mode.

Each START/STOP command is answered with an acknowledgement message (CAN message address 0009). The acknowledgement message contains the current temperature value and the lower 6 bits of the controller status.

## 11.5.3 Measurement pause command

The parameter “value” in the measurement pause command (address 50<sub>n</sub>) has the following structure:

Bit no.	Name	Meaning
Bit no.	Name	Meaning
Bit 0...7	Duration of measurement pause	Time in 10 ms resolution until the measurement pause is automatically switched off, at least 50 ms. Values smaller than 50 ms deactivate the measurement pause.
Bit 8...15	Unused	

Together with the measurement pause command, the maximum measurement pause duration (50...2550 ms) is transmitted. If the RESISTRON<sup>®</sup> Temperature Controller RES-5009 is to remain in the measurement pause for longer than 2550 ms, a new measurement pause command must be sent before the measurement pause duration expires. This ensures that the controller does not remain in the measurement pause state uncontrolled in the absence of CAN communication. To end the measurement pause prematurely, a measurement pause command with duration < 5 (corresponding to < 50 ms) can be sent. The controller then immediately ends the measurement pause and switches to measurement mode.

Each measurement pause command is answered with an acknowledgement message (CAN message address 0009). The acknowledgement message contains the lower 6 bits of the controller status and the last temperature measured before the measurement pause.

#### 11.5.4 Alloy/range (heating band alloy TCR/temperature range)

With CAN message address 0008, the RESISTRON<sup>®</sup> Temperature Controller RES-5009 can be configured for different heating band alloys and temperature ranges ( $T_{max}$ ). The set heating band alloy and the set temperature range are permanently stored in the controller and will be retained even after a power failure. The current setting can be read back via CAN message address 11. The controller is delivered with setting 1, i. e. TCR = 1100 ppm and temperature range = 300 °C.

If “variable” is selected (value 11) under alloy/range (CAN message address 0008),

- the temperature coefficient TCR of the heating element material can be set via CAN message address 000A
- the temperature range can be set via CAN message address 0014<sub>h</sub> and
- the maximum permissible setpoint  $T_{max}$  can be set via CAN message address 0013<sub>h</sub>.

If a setpoint is specified that is greater than the maximum permitted temperature  $T_{max}$ , it will be limited to the maximum value.

The scaling of the analogue output for the ACTUAL temperature depends on the selected temperature range:

Temperature range	Scaling
200 °C and 300 °C	0...10 VDC corresponding to 0...300 °C
400 °C and 500 °C	0...10 VDC corresponding to 0...500 °C



#### CAUTION

After changing the alloy/range, the AUTOCAL function must be executed.

#### 11.5.5 Querying ACTUAL temperature

The RESISTRON<sup>®</sup> Temperature Controller RES-5009 responds to the command for querying the actual value with the value of the current ACTUAL temperature in °C. Negative temperatures are marked by the “prefix” bit (most significant bit).

### 11.6 Sending CAN messages

The following table shows the complete command range of the RESISTRON<sup>®</sup> Temperature Controller RES-5009 when sending CAN messages:

Address (hex)	Value (dec.)	Meaning
0000	0... $T_{max}$	Current setpoint 0 (in °C)
0001	0... $T_{max}$	Current setpoint 1 (in °C)
0002	0... $T_{max}$	Current setpoint 2 (in °C)
0003	0... $T_{max}$	Current setpoint 3 (in °C)
0004	-20... $T_{max}$	Current actual value (in °C)
0005	(↪ 11.6.1)	Current complete status of the controller

Address (hex)	Value (dec.)	Meaning
0006	3 digits (BCD coded)	Digit 1...3 of the 6-digit device number (e. g. 654 <b>321</b> )
0007	3 digits (BCD coded)	Digit 4...6 of the 6-digit device number (e. g. <b>654</b> 321)
0008	0...40	Current calibration temperature (in °C), channel 0
0009	(↪ 11.6.2)	Acknowledgement message (current actual value with reduced controller status)
000A	3...99	Current upper temperature monitoring limit
000B	0...15 (↪ chap. 11.5, address 0008)	Current heating band alloy/temperature range
000C	0...65535	Current alarm and Autocal status (↪ section 11.6.3 "Alarm /AUTOCAL status" on page 90)
000D	0 1 2	Hold mode: OFF Hold mode: ON Hold mode: 2 seconds
000E	0 1 2	AUTOCOMP status: OFF AUTOCOMP status: ON AUTOCOMP status: AUTO
000F	0...500	Maximum setpoint
0010	0...999	Software revision
0011	0...99	Software variant (standard value: 00)
0012	400...4000	Current variable temperature coefficient (TCR in ppm/K), channel 0
0013	0 1 2	Temperature OK bit: OFF Temperature OK bit: active when Setpoint=Actual Temperature OK bit: active when Setpoint=Actual with latch function
0014	3...99	Lower temperature monitoring limit
0015	3...99	Upper temperature monitoring limit
0016	0 1	Temperature diagnosis: OFF Temperature diagnosis: ON
0017	0...99	Temperature diagnosis delay in 0.1 s
0018	0...999	Heating time monitoring in 0.1 s
0019	17...30	Measurement impulse length 0.1 ms
001A	0 1 2 3	Temperature range 200 °C Temperature range 300 °C Temperature range 400 °C Temperature range 500 °C
001B		Current device type (RES-5009 = value 33)

Address (hex)	Value (dec.)	Meaning
001D		Status of internal clock: Bit 0: Internal clock present Bit 1: Time inaccurate Bit 2: Time invalid Bit 3: Internal clock is being set (only for internal purposes)
001E	0xss00 ss={00...59}	Seconds 'ss' from temporary memory
001F	0xhhmm hh={00...23}, mm={00...59}	Hours 'hh' and minutes 'mm' from temporary memory
0020	0xMMDD MM={01...12}, DD={01...31}	Month 'MM' and day 'DD' from temporary memory 01->January, 02->February, ... 01->1st day of month, 02-> 2nd day of month
0021	0xJJJJ	Year 'YYYY' from temporary memory
0022	0xXXXX	Confirmation on command 0016 <sub>h</sub> (save time temporarily, HH, MM) with repetition of values
0023	0xXXXX	Confirmation on command 0017 <sub>h</sub> (save time temporarily, SS) with repetition of values
0024	0xXXXX	Confirmation on command 0018 <sub>h</sub> (save date temporarily, YYYY) with repetition of values
0025	0xXXXX	Confirmation on command 0019 <sub>h</sub> (save date temporarily, MM, DD) with repetition of values
0026	0	Confirmation on command 0004 <sub>h</sub> 31 <sub>d</sub> (read time and date from real-time clock and save temporarily)
0027	0	Confirmation on command 0004 <sub>h</sub> 32 <sub>d</sub> (save temporarily changed values of time and date in real-time clock)
0028	-1, 0...40°C	Current calibration temperature (in °C), channel 1
0029	-1, 0...40°C	Current calibration temperature (in °C), channel 2
002A	-1, 0...40°C	Current calibration temperature (in °C), channel 3
002B	-1, 0...40°C	Current calibration temperature (in °C), channel 4
002C	-1, 0...40°C	Current calibration temperature (in °C), channel 5
002D	-1, 0...40°C	Current calibration temperature (in °C), channel 6
002E	-1, 0...40°C	Current calibration temperature (in °C), channel 7
002F	400...4000	Current variable temperature coefficient (TCR in ppm/K), channel 1
0030	400...4000	Current variable temperature coefficient (TCR in ppm/K), channel 2
0031	400...4000	Current variable temperature coefficient (TCR in ppm/K), channel 3
0032	400...4000	Current variable temperature coefficient (TCR in ppm/K), channel 4
0033	400...4000	Current variable temperature coefficient (TCR in ppm/K), channel 5

<b>Address (hex)</b>	<b>Value (dec.)</b>	<b>Meaning</b>
0034	400...4000	Current variable temperature coefficient (TCR in ppm/K), channel 6
0035	400...4000	Current variable temperature coefficient (TCR in ppm/K), channel 7
0050	0...65535	CAN protocol version
0051	0...7	Active channel

### 11.6.1 Controller status

The controller status is sent on request and contains all important information about the status of the RESISTRON® Temperature Controller RES-5009. In the event of an alarm, an exact error diagnosis can be performed on the basis of the error message (↪ section 9.15 "Error messages" on page 51).

The controller status is coded as follows:

Bit no.	Name	Meaning
0...1	Setpoint no.	Number of the last setpoint used (0...3)
2	Control active	0: Measurement mode 1: Control mode
3	Temperature OK	0: Actual value is outside the specified temperature monitoring band 1: Actual value is inside the specified temperature monitoring band
4	Alarm	0: no alarm 1: Alarm active
5	AUTOCAL blocked	0: "AUTOCAL" function possible 1: "AUTOCAL" function not possible (cooling off phase)
6	AUTOCAL active	0: "AUTOCAL" function is not executed 1: "AUTOCAL" function is being executed
7	Hold active	0: Hold is not active 1: Hold is active
8...11	Error message	Error no. 0...13 (↪ section 9.15 "Error messages" on page 51)
12	START requested	START request was received
13	Start input	0: Start from external start input "START with setpoint 0" or Start request via CAN 1: Start from external start input "START with setpoint 1"
14	Undervoltage	0: Supply voltage in working range 1: Supply voltage too low (undervoltage)
15	Temperature reached	When the actual temperature has reached 95% of the setpoint temperature, this status bit is set. As soon as the control mode is ended or an alarm occurs, this status bit will be reset.

### 11.6.2 Acknowledgement message

After each START/STOP command, the RESISTRON<sup>®</sup> Temperature Controller RES-5009 automatically sends an acknowledgement message (CAN message address 0009). It contains the current actual value and the most important status information:

Bit no.	Name	Meaning
0...8	Actual value	Value of the current actual value (in °C)
9	Prefix	Prefix of the actual value. 0: positive, 1: negative
10...11	Setpoint no.	Number of the last setpoint used (0...3)
12	Control active	0: Measurement mode 1: Control mode
13	"Temperature OK" bit	0: Actual value is outside the specified temperature monitoring band 1: Actual value is inside the specified temperature monitoring band
14	Alarm	0: no alarm 1: Alarm active
15	Autocal blocked	0: AUTOCAL function possible 1: AUTOCAL function not possible (cooling off phase)

### 11.6.3 Alarm /AUTOCAL status

Bit no.	Name	Meaning
0...9	Error code	three-digit error code
10...11	Error action	0: Perform RESET 1: Perform AUTOCAL 2: Check configuration
12...15	Autocal status	0: AUTOCAL function possible (not active and not blocked) 1: AUTOCAL function is active 2: Check for falling actual value 3: Wait until AUTOCAL request is withdrawn 4: Wait whether AUTOCOMP will be started 5: AUTOCOMP function active 6: AUTOCAL function blocked, because heating band is still warm 7: AUTOCAL function blocked, because test mode is active 8: AUTOCAL function blocked, because START is active 9: AUTOCAL function blocked, because PREHEAT is active 10: AUTOCAL function blocked, because DETACH is active (not used) 11: AUTOCAL function blocked, because RESET is active 12: AUTOCAL function blocked, because Alarm is active 13: reserved 14: AUTOCAL function is aborted

### 11.6.4 Device number (serial number)

The device number is assigned individually for each device. The device number is the unique identification of the RESISTRON® Temperature Controller RES-5009 in a CAN network. The device number is divided into two parts to comply with the message format (↩ section 11.4 "ROPEX CAN protocol" on page 79). Each part contains three digits stored in "Value.H" and "Value.L" in BCD format.

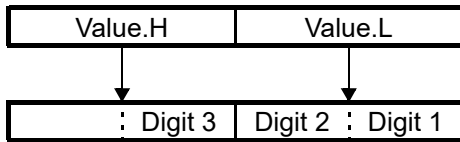

### 11.7 Reading and setting the internal clock

Since only a maximum of two byte values are transmitted per CAN message, the time information must be split over several CAN messages. To ensure that the time information is exchanged consistently between the internal clock and the CAN interface, the internal clock is not accessed directly, but via an intermediate buffer. With CAN message 0x0004, 0x001F, the current system time is transferred to the intermediate buffer. The intermediate buffer can then be read out with further CAN messages.

To set the internal clock, first all time information must be loaded into the intermediate buffer and then the content of the intermediate buffer can be transferred to the internal clock with CAN message 0x0004, 0x0020. It then continues to run with the transferred time information.

The status of the internal clock can be requested via CAN message 0x0004, 0x001E. The response 0x001D contains 4 bits:

- Bit 0: Internal clock present (indicates that the internal clock is present)
- Bit 1: Time inaccurate (the temperature compensation has been deactivated, because the voltage buffering has reached a critical value)
- Bit 2: Time invalid (there was a fallback to the last stored time, because the voltage buffering failed)
- Bit 3: Setting clock (at the moment the transfer from the intermediate buffer to the internal clock is taking place).

## 12 Factory settings

The RESISTRON® Temperature Controller RES-5009 is configured as follows from the factory:

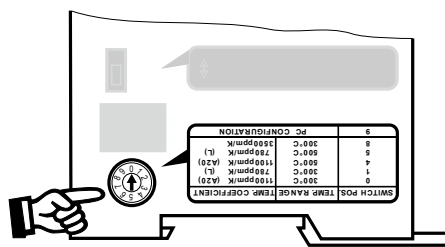
<p>Rotary encoder switch for Heating element alloy and Temperature range</p>		<p>Heating element alloy: Alloy A20 Temperature range: 300 °C</p> <p>Rotary encoder switch: Position "0"</p>
--	---	--

<p><u>Slide switch</u> for Alarm relay</p>		<p>Alarm relay active in case of alarm</p>
<p>Automatic Phase correction (AUTOCOMP)</p>		<p>AUTOCOMP: off</p>
<p>Temperature diag- nosis</p>		<p>Temperature diagnosis: deactivated</p>
<p>Heat-up time moni- toring</p>		<p>Heat-up time monitoring: deactivated</p>

### 13 Maintenance

The controller does not require any special maintenance. Regular checking and retightening of the connection terminals is recommended. Dust deposits on the controller can be removed with dry compressed air when the power is off.

	<p><b>WARNING</b></p> <p>Dust deposits and dirt from liquids result in a loss of function. Therefore, installation in a control cabinet or junction box starting from protection class IP<sub>54</sub> is recommended.</p>
--	--

### 14 Disposal



This device falls under the EC Directive 2012/19/EU to reduce the increasing amount of electronic waste. The aim of the EC directive is to reduce waste from electrical and electronic equipment and to dispose of it in an environmentally friendly manner. In order to ensure material recycling or proper disposal, take the device to the municipal collection points provided for this purpose. Observe the local regulations.



Careless and uncontrolled disposal can cause damage to the environment and human health. Help protect the environment and human health, and dispose of the product or recycle it responsibly.



	NOTE
This device must not be disposed of in the residual waste bin!	

## 15 Technical data





### CAUTION

Operation of the temperature controller outside of these technical specifications results in loss of warranty and can cause defects.

<b>Design</b>	Housing for electrical cabinet mounting Can be snapped on to TS35 top hat rail (35mm) in accordance with EN 60715 Basic surface: 90x75 mm; depth: 135 mm (incl. connection terminals)
<b>Line voltage</b>	Connected between neutral conductor and an outside conductor: 110 VAC -15%...300 VAC +10% or Connected between two outside conductors: 110 VAC -15%...480 VAC +10%   <b>CAUTION</b> The voltage between outside conductor and earth must not exceed 300VAC.
<b>Power supply</b>	Symmetrical TN or TT network Overvoltage category III   <b>CAUTION</b> Operation in voltage-free network (e. g. IT network) only after checking with ROPEX.
<b>Line frequency</b>	47...63 Hz, automatic frequency adjustment in this range
<b>Current consumption</b> (Primary current of the impulse transformer)	$I_{\max} = 5 \text{ A}$ (ED = 100%) $I_{\max} = 25 \text{ A}$ (ED = 20%, playing time 1 min. A booster must be used for higher power requirements.)
<b>24VDC power supply</b> Terminals 5+7	24 VDC, $I_{\max} = 100 \text{ mA}$ (control mode), 1 A (switch-on current) Tolerance: $\pm 10\%$ SELV or PELV supplied from maximum 300VAC, Cat II
<b>Measurement range</b>	Secondary voltage $U_R$ : 0.4 ...120 VAC (lower voltages with MOD 01, higher voltages with a ROPEX series resistor) Secondary current $I_R$ : 30...500 A with current transformer PEX-W4/W5 (lower currents: Secondary cables lead through the current transformer several times, higher currents with a load resistor) The dimensioning is made in the ROPEX application report.

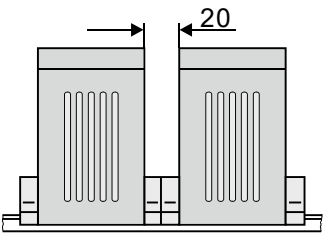
<p><b>CAN interface</b></p>	<p>CAN interface CAN 2.0A as per ISO 11898</p> <p>Baud rates: 10 kBaud; 20 kBaud; 50 kBaud; 100 kBaud, 125 kBaud; 205 kBaud; 250 kBaud; 500 kBaud; 800 kBaud; 1 MBaud</p> <p>SUB-D9 connector as per CiA 303/1 specification</p>
<p><b>CAN protocol</b></p>	<p>CANopen protocol (as per CiA profile 301 in version 4.2.0)</p> <p>ROPEX CAN protocol</p>
<p><b>Heating element type and temperature range</b></p>	<p>Apart from setting via the rotary encoder switch or the CAN interface, the setting for the temperature range and temperature coefficient can be made through the ROPEX visualisation software (see section 9.8 "USB interface for visualisation software ROPEXvisual<sup>®</sup>" on page 47):</p> <p>Temperature range: 200 °C, 300 °C, 400 °C or 500 °C          Temperature coefficient: 400...4000ppm/K (variable setting range)</p> <p>Five areas can be set over rotary coding switches or CAN interface:</p> <ul style="list-style-type: none"> <li>Temperature coefficient 1100ppm/K, 0...300°C (e. g. alloy A20)</li> <li>Temperature coefficient 780ppm/K, 0...300 °C (e. g. alloy L)</li> <li>Temperature coefficient 1100ppm/K, 0...500 °C (e. g. alloy A20)</li> <li>Temperature coefficient 780ppm/K, 0...500°C (e. g. alloy L)</li> <li>Temperature coefficient 3500ppm/K, 0...300°C</li> </ul> <p>Please take the necessary setting from the ROPEX application report</p>
<p><b>Analogue output</b> (Actual value) Terminals 17+7</p>	<p>0...10 VDC, <math>I_{max} = 5 \text{ mA}</math>          corresponding to 0...300°C or 0...500°C          Precision: <math>\pm 1\%</math> plus 50 mV</p>
<p><b>Alarm relay</b> Terminals 12, 13, 14</p>	<p><math>U_{max} = 30 \text{ V (DC/AC)}</math>, <math>I_{max} = 0.2 \text{ A}</math>, changeover contact, voltage-free          (for UL certification: <math>I_{max} = 0.2 \text{ A}</math>)</p>
<p><b>Power loss</b></p>	<p>Max. 20 W</p>
<p><b>MTTF as per ISO 13849-1</b></p>	<p>1522 years (see EN ISO 13849-1, table C.3, Triacs)</p>
<p><b>Ambient conditions</b></p>	<p>Maximum altitude 2000 m          Ambient temperature: +5...+45 °C          Maximum relative humidity: 80% at temperatures up to +31 °C, decreasing linearly to 50% relative humidity at +45 °C.</p>
<p><b>Degree of protection</b></p>	<p>IP 20</p> <p> <b>CAUTION</b>  <b>When the terminals are open, the screw must be screwed in to ensure contact protection.</b></p>

<b>Mounting</b>	<p>If several devices are mounted on a top-hat rail, a minimum distance of 20 mm must be maintained.</p> <p>When mounting on a horizontal top hat rail, the movable latch, which is necessary for fastening, must face downward.</p> <p>When mounting on a vertical top hat rail, end holders must be installed on both sides to fasten the controller mechanically.</p>	
<b>Weight</b>	Approx. 0,7 kg (incl. plug-in terminal parts)	
<b>Housing material</b>	Plastic, polycarbonate, UL-94-V0	
<b>Connecting cable</b> Type/cross-sections	rigid or flexible; 0.2...2.5 mm <sup>2</sup> (AWG 24...12) via pluggable terminals  Pluggable terminals: Tightening torque: 0.5...0.6 Nm (Screwdriver: SZS 0.6x3.5 mm)	
<p> <b>CAUTION</b>                  If ferrules are used, they must be crimped in accordance with DIN 46228 and IEC/EN 60947-1. Otherwise, correct electrical contact in the terminals is not guaranteed.</p>		

## 16 Dimensions

RESISTRON<sup>®</sup> Temperature Controller RES-5009

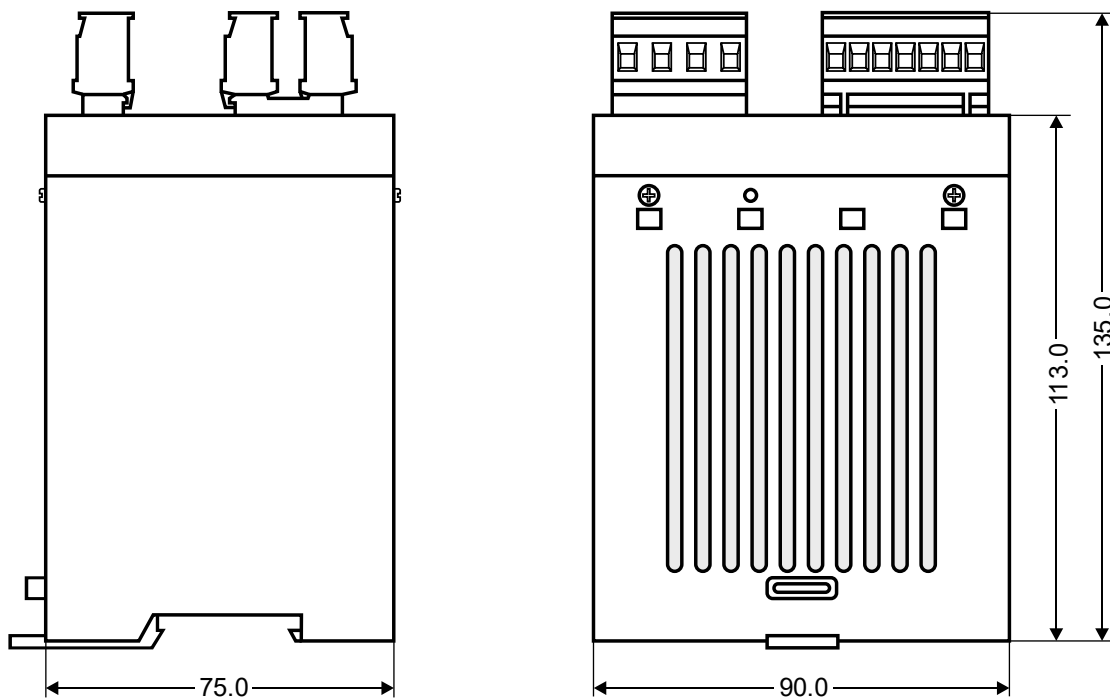

## 17 Modifications (MODs)

The RESISTRON<sup>®</sup> Temperature Controller RES-5009 is suitable for very many welding applications due to its universal design.

A device modification (MOD) is available for the RESISTRON<sup>®</sup> Temperature Controller RES-5009 to implement special applications.







The modifications must be ordered separately.

### MOD 01

Supplemental booster for small secondary voltages ( $U_R = 0.2 \dots 60 \text{ VAC}$ ). This modification is e. g. necessary for very short or for low-resistance heating elements.

## 18 How to order

	<p><b>Controller RES-5009</b>                  Art. no. 7500900</p> <p>Scope of delivery: Controller with plug-in terminal parts (without transformer)</p> <p><b>Modification MOD . . (Optional, if necessary)</b>                  e. g.                  → <b>01</b>: MOD 01, art. no. 800001 (additional booster for low voltages)</p> <p>The article numbers of the controller and of the desired modification (optional) must be specified when ordering,                  E. g. RES-5009 + MOD 01 (controller with additional gain for low voltage)                  Order of art. no. 7500900 + 800001</p>
	<p><b>Current transformer PEX-W5</b>                  Art. no. 885107</p>
	<p><b>HCB-1 high-current busbar</b>                  Art. no. 885110</p>
	<p><b>Monitoring current transformer MSW-2</b>                  Art. no. 885212</p>
	<p><b>Line filter LF- . . . . .</b>                  → <b>06480</b>: Continuous current 6 A, 480VAC, art. no. 885500 (with UL certification)  <b>10520</b>: Continuous current 10 A, 520 VAC, art. no. 885504 (with UL and CSA certification)  <b>35480</b>: Continuous current 35 A, 480 VAC, art. no. 885506  <b>50520</b>: Continuous current 50 A, 520 VAC, art. no. 885509 (with UL and CSA certification)</p>

	<p><b>Impulse transformer</b></p> <p>For design and order specifications, see ROPEX application report                  Design in accordance with EN 61558 in IP00                  Available with UL certifications and thermal switch, if necessary.                  In addition, we can individually design and offer you an series transformer.</p>
	<p><b>Temperature disp. ATR- .</b></p> <p>  <b>3:</b> 300 °C range, art. no. 882130   <b>5:</b> 500 °C range, art. no. 882150</p>
	<p><b>Booster B- . . .</b></p> <p>  <b>075415:</b> Impulse load cap. 75 A, 415 VAC, art. no. 885302  <b>100400:</b> Impulse load cap. 100 A, 400 VAC, art. no. 885304</p>
	<p><b>Lines</b></p> <p>For design and order specifications, see ROPEX application report</p>

## 19 Index

### Numbers

24 VDC power supply 93

### A

AA bit 35  
AC bit 30  
ACTUAL temperature 85  
Actual value 38  
Actual value output 46  
AG bit 35  
AL bit 27, 35  
Alarm 35  
Alarm output 50  
Alarm relay 23, 94  
Alloy 22, 28, 85  
Ambient conditions 94  
Ambient temperature 94  
Application report 14, 17  
AutoBaud 59, 77  
AUTOCAL 12, 27  
    active 35  
    blocked 31, 35  
    start 30  
AUTOCAL function blocked 31  
AUTOCOMP 40  
Automatic phase correction 40  
Automatic zero calibration 27, 30  
AUTOTUNE 12  
AUX interface 48

### B

Baud rate 58, 77  
Booster 20, 98  
Booster connection 47  
Burning in the heating element 25, 27

### C

CAN interface 94  
CAN messages  
    receive 79  
    send 85  
CAN protocol 77, 79, 94  
CANopen 58  
Changing the heating element 26, 28  
Circuit breaker 16  
Control active 36  
Control information 69  
Controller status 89  
Current transformer 10, 17, 97

### D

Data storage 49

Date 49  
Degree of protection 94  
Design 93  
Device view 21  
Dimensions 95

### E

Error diagnosis 12  
Error messages 51  
Error ranges 56  
External switching amplifier 20, 98

### F

Factory settings 91  
Fuse 16

### H

Heartbeat 62  
Heating band alloy 85  
Heating element 9  
Heating element type 94  
Heat-up time monitoring 42  
High altitude 94  
Hold mode 43  
Humidity 94

### I

Impulse transformer 10, 16, 98  
Input data 30  
Installation 13  
Installation rules 13

### L

LEDs 29, 61, 78  
Line filter 10, 16, 17, 97  
Line frequency 12, 93  
Line voltage 93  
LSS 61

### M

Mains connection 16  
Measurement impulse duration 40  
Measurement interruption 38  
Measurement pause 32  
Measurement range 93  
Modification (MOD) 96, 97  
Monitoring current transformer 97  
Mounting 95  
MP bit 32  
MSW-2 97  
MU bit 38

**N**

Node address 60  
Node ID 60

**O**

Object directory 63  
Operating hours counter 49  
Output data 35  
Overcurrent device 16

**P**

PDO mapping 71  
PEX-W5 97  
Phase correction 40  
Power loss 94  
Power supply 93

**R**

RA bit 27, 36  
Reset 32  
ROPEX CAN 77  
ROPEXvisual 47, 48  
RS bit 32

**S**

Setpoint 33  
Setpoint specification 83  
Setup requirements 14  
Standby mode 45  
Start 27, 31  
START command 73  
Startup 26  
START/STOP command 84  
Status information 70

System diagnosis 47  
System monitoring 50

**T**

TCR 9  
TCR calculator 74  
TE bit 35  
Technical data 93  
Temperature coefficient 9  
Temperature control 11  
Temperature diagnosis 42  
Temperature display 46, 47, 98  
Temperature OK 35  
Temperature range 22, 85, 94  
Temperature reached 35, 89  
Thermal impulse process 11  
Time 49  
Time stamp 49  
TO bit 35  
Total cycles counter 48  
Transformer 10, 16, 98

**U**

Undervoltage detection 45  
USB interface 47  
Use 11

**V**

Visualisation software 47

**W**

WA bit 35  
Wiring 14, 16  
Wiring diagram (standard) 19

## По вопросам продаж и поддержки обращайтесь:

Алматы (727)345-47-04  
Ангарск (3955)60-70-56  
Архангельск (8182)63-90-72  
Астрахань (8512)99-46-04  
Барнаул (3852)73-04-60  
Белгород (4722)40-23-64  
Благовещенск (4162)22-76-07  
Брянск (4832)59-03-52  
Владивосток (423)249-28-31  
Владикавказ (8672)28-90-48  
Владимир (4922)49-43-18  
Волгоград (844)278-03-48  
Вологда (8172)26-41-59  
Воронеж (473)204-51-73  
Екатеринбург (343)384-55-89

Иваново (4932)77-34-06  
Ижевск (3412)26-03-58  
Иркутск (395)279-98-46  
Казань (843)206-01-48  
Калининград (4012)72-03-81  
Калуга (4842)92-23-67  
Кемерово (3842)65-04-62  
Киров (8332)68-02-04  
Коломна (4966)23-41-49  
Кострома (4942)77-07-48  
Краснодар (861)203-40-90  
Красноярск (391)204-63-61  
Курск (4712)77-13-04  
Курган (3522)50-90-47  
Липецк (4742)52-20-81

Магнитогорск (3519)55-03-13  
Москва (495)268-04-70  
Мурманск (8152)59-64-93  
Набережные Челны (8552)20-53-41  
Новокузнецк (3843)20-46-81  
Ноябрьск (3496)41-32-12  
Новосибирск (383)227-86-73  
Омск (3812)21-46-40  
Орел (4862)44-53-42  
Оренбург (3532)37-68-04  
Пенза (8412)22-31-16  
Петрозаводск (8142)55-98-37  
Псков (8112)59-10-37  
Пермь (342)205-81-47

Ростов-на-Дону (863)308-18-15  
Рязань (4912)46-61-64  
Самара (846)206-03-16  
Санкт-Петербург (812)309-46-40  
Саратов (845)249-38-78  
Севастополь (8692)22-31-93  
Саранск (8342)22-96-24  
Симферополь (3652)67-13-56  
Смоленск (4812)29-41-54  
Сочи (862)225-72-31  
Ставрополь (8652)20-65-13  
Сургут (3462)77-98-35  
Сыктывкар (8212)25-95-17  
Тамбов (4752)50-40-97  
Тверь (4822)63-31-35

Тольятти (8482)63-91-07  
Томск (3822)98-41-53  
Тула (4872)33-79-87  
Тюмень (3452)66-21-18  
Ульяновск (8422)24-23-59  
Улан-Удэ (3012)59-97-51  
Уфа (347)229-48-12  
Хабаровск (4212)92-98-04  
Чебоксары (8352)28-53-07  
Челябинск (351)202-03-61  
Череповец (8202)49-02-64  
Чита (3022)38-34-83  
Якутск (4112)23-90-97  
Ярославль (4852)69-52-93

**Россия** +7(495)268-04-70

**Казахстан** +(727)345-47-04

**Беларусь** +(375)257-127-884

**Узбекистан** +998(71)205-18-59

**Киргизия** +996(312)96-26-47

эл.почта: [rxe@nt-rt.ru](mailto:rxe@nt-rt.ru) || сайт: <https://ropex.nt-rt.ru/>